

Higher cutting performance, lower fuel consumption.

Surface Miner 2200 SM 3.8



Efficient optimizations of the 2200 SM 3.8

02
03

SAFETY EQUIPMENT

Comprehensive safety package ensuring compliance with specific mining regulations.

CABIN

Fully glazed operator's cabin for productive working.

WELL-BALANCED WEIGHT DISTRIBUTION

Supplementary weights ensure optimum weight distribution.

FOCUSING ON CUSTOMER BENEFITS

Increasing the cutting performance of the 2200 SM 3.8 by up to 25% in comparison with the standard model means a huge step forward. It was achieved by a meticulous analysis of the cutting and transport processes. This resulted in the surface miner being subjected to a comprehensive process of improvement. The main components coming under close scrutiny included the cutting drum housing and cutting drum.

Optimizing the durability of individual components of the 2200 SM 3.8 and simplifying the maintenance procedures additionally resulted in an increase of the miner's effective uptime by up to 15%. The improvements in this area focused in particular on the track units and machine frame.



OPTIMIZED CUTTING DRUM HOUSING

Larger openings for optimized material transport.

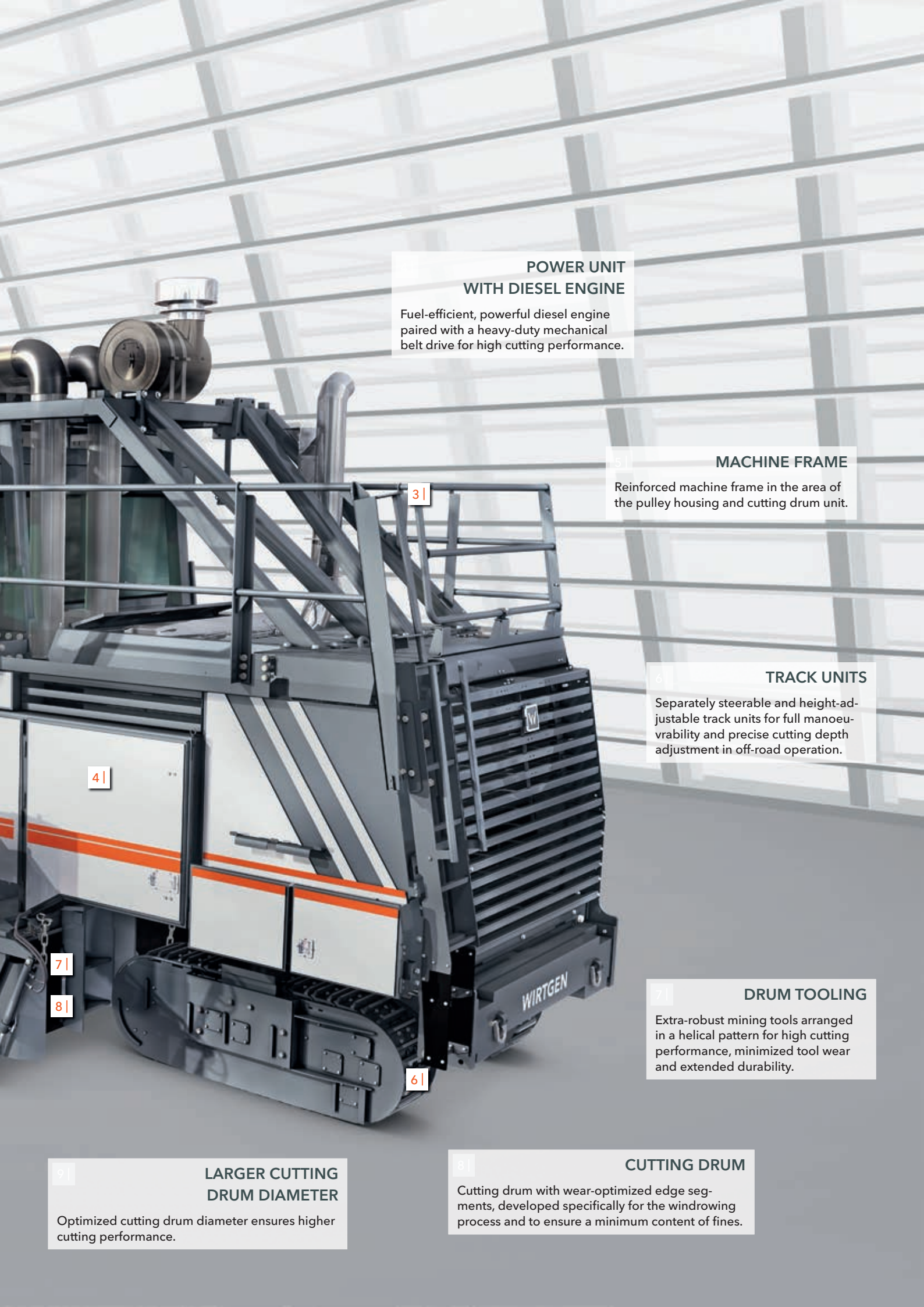

POWER UNIT WITH DIESEL ENGINE

Fuel-efficient, powerful diesel engine paired with a heavy-duty mechanical belt drive for high cutting performance.

MACHINE FRAME

Reinforced machine frame in the area of the pulley housing and cutting drum unit.

TRACK UNITS

Separately steerable and height-adjustable track units for full manoeuvrability and precise cutting depth adjustment in off-road operation.

DRUM TOOLING

Extra-robust mining tools arranged in a helical pattern for high cutting performance, minimized tool wear and extended durability.

CUTTING DRUM

Cutting drum with wear-optimized edge segments, developed specifically for the windrowing process and to ensure a minimum content of fines.

LARGER CUTTING DRUM DIAMETER

Optimized cutting drum diameter ensures higher cutting performance.

4 |

3 |

5 |

6 |

7 |

8 |

6 |

9 |





Efficient.

A BIG IDEA. MINING VALUABLE USEFUL MINERALS SELECTIVELY NOT IN FOUR WORK STEPS BUT IN A SINGLE OPERATION. WITH THE WIRTGEN 2200 SM 3.8. A HIGH-PERFORMANCE SURFACE MINER IN HEAVY-DUTY DESIGN FOR RELIABLE, CONTINUOUS OPERATION AROUND THE CLOCK. EQUIPPED WITH OUR EXPERTISE IN STATE-OF-THE-ART CUTTING TECHNOLOGY. WITHOUT DRILLING AND BLASTING BUT IN A HIGHLY ENVIRONMENTALLY GENTLE PROCESS YIELDING MATERIAL OF THE PUREST QUALITY. WIRTGEN SURFACE MINING - EXPLOITING MINERAL DEPOSITS THE INTELLIGENT WAY.



25% more cutting performance 15% less fuel consumption

CONTINUOUS PROCESS OF IMPROVEMENT

A continuous process of improvement for our customers' benefit is one of the fundamental company philosophies cultivated by WIRTGEN – the market leader in surface mining.

Increasing both the cutting performance and effective uptime is one of our main priorities in surface mining. Selectivity is additionally undergoing a continuous improvement process.

POSITIVE EFFECTS EXEMPLIFIED IN COAL MINING

A series of improvements implemented in the WIRTGEN 2200 SM 3.8 surface miner for use in, for example, Indian coal mines resulted in a significant increase in productivity in comparison with the standard model.

The miner's track record shows an increase in cutting performance by 25% and simultaneous reduction of the specific diesel consumption by 15%.



The new 2200 SM 3.8 impresses with an increase in cutting performance by 25% and a reduction in fuel consumption by 15%.



The improved miner cuts soft rock selectively at maximum production rates and economic efficiency.

Economical mining of soft rock

HIGH PRODUCTION RATES USING THE WINDROWING PROCESS

Mining soft rock at maximum production rates and economic efficiency - the 2200 SM 3.8 surface miner has been developed to meet exactly these criteria for success. The centre-piece of the compact, yet powerful machine is the 3.8 m wide cutting drum which offers numerous innovative features. It cuts soft rock with unconfined compressive strengths of up to 35 MPa, such as coal or salt, in a highly productive process, depositing it in three windrows behind the machine.

The cutting drum unit represents state-of-the-art technology - based on optimizations that were the result of extensive field testing. It offers maximum cutting performance while fully utilizing the machine's engine power at the same time. Further positive effects include low specific fuel consumption rates, optimized tool use and minimized fines content as a result of gentle material transport.



CUTTING PERFORMANCE, LAMINAR OR BRITTLE SOFT ROCK (SUCH AS COAL)

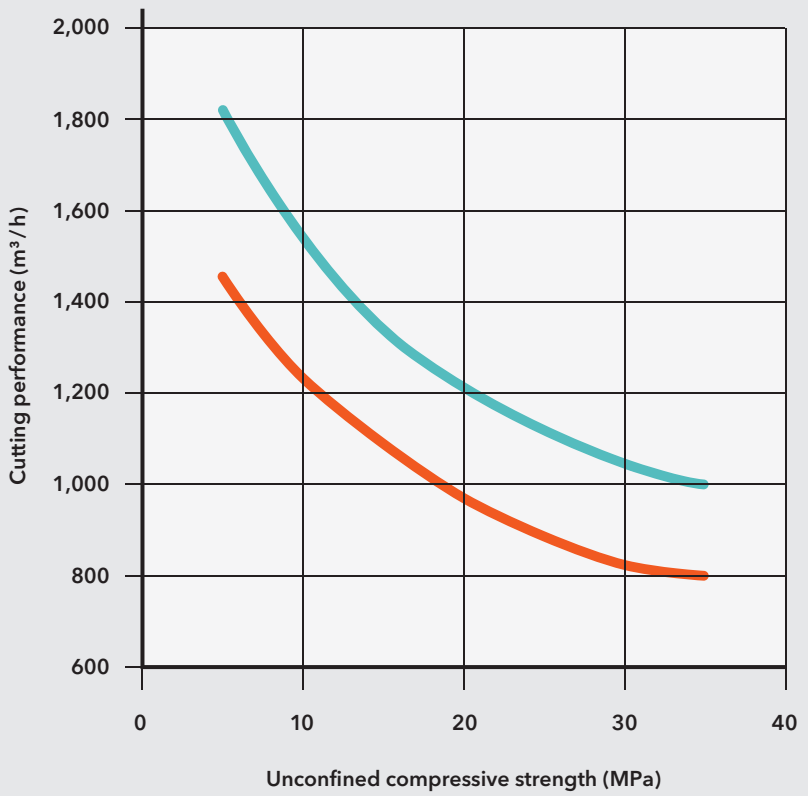

- optimized for soft rock
- standard

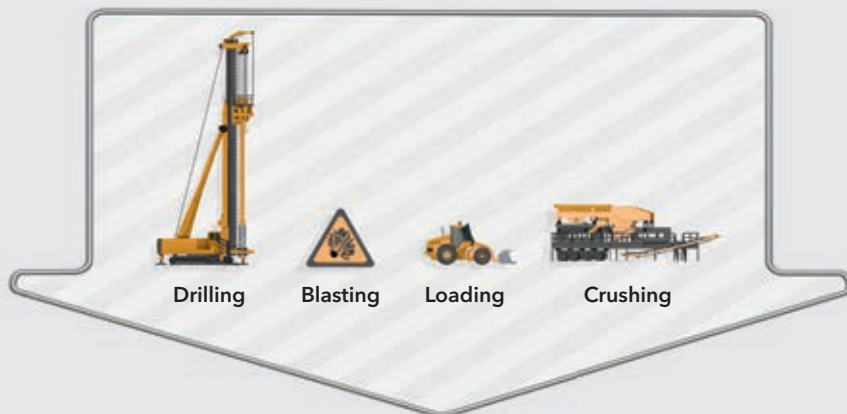

A single operation instead of four - with the 2200 SM 3.8 surface miner from WIRTGEN.





Feel the power.

WIR
RTGEN

THE TREMENDOUS CUTTING POWER OF WIRTGEN CUTTING DRUMS CANNOT ONLY BE SEEN. IT CAN LITERALLY BE FELT. BECAUSE OF THE HEAVY-DUTY CUTTING DRUM DESIGN TAILORED TO PERFORMANCE REQUIREMENTS. MANUFACTURED FROM EXTREMELY WEAR-RESISTANT MATERIALS. BASED ON SPECIFIC EXPERTISE GAINED IN SEVERAL DECADES OF EXPERIENCE IN CUTTING TECHNOLOGY. COST-OPTIMIZED. SO THAT WE CANNOT ONLY MEET BUT EXCEED YOUR REQUIREMENTS IN EFFICIENCY AND PRODUCTIVITY.

Cutting drum unit precisely tailored to the mining of soft rock

3.8-M WIDE CUTTING DRUM UNIT OPTIMIZED FOR SOFT ROCK

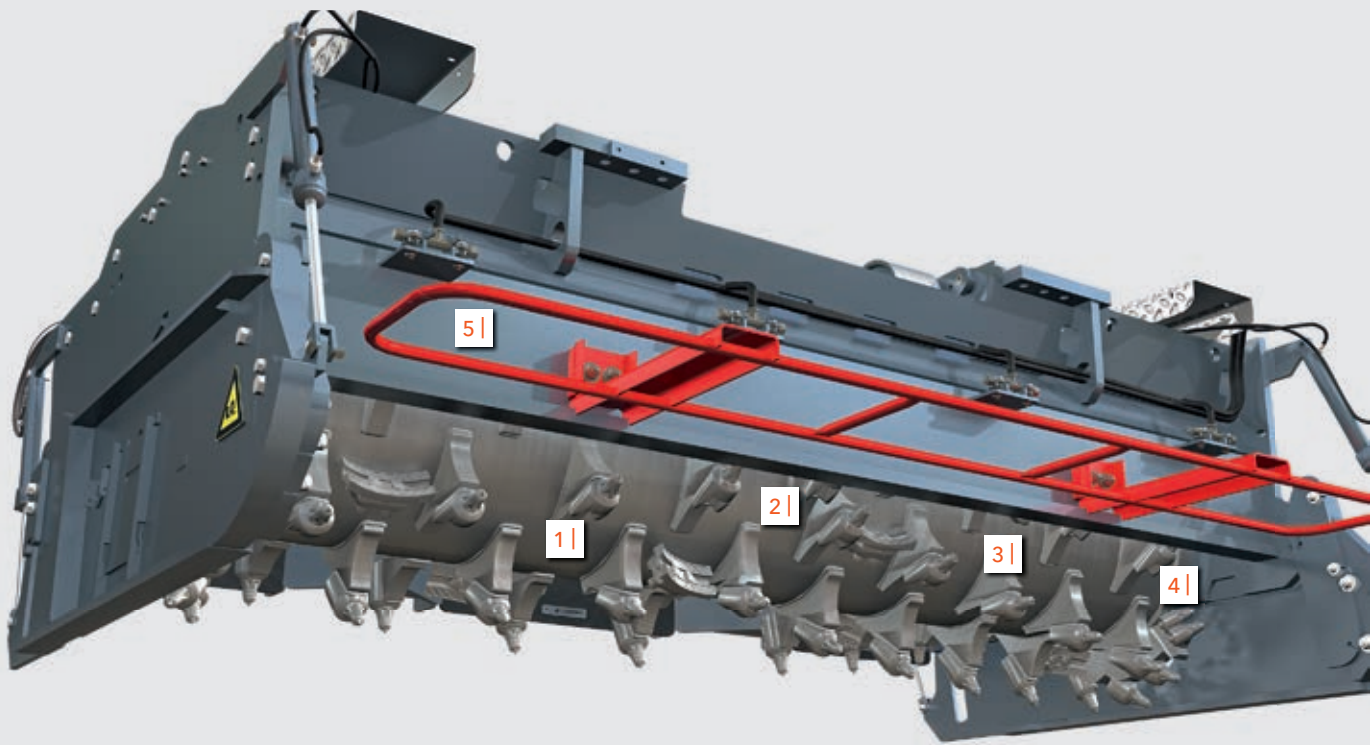

1| Cutting circle diameter increased from 1,115 mm to 1,300 mm for high working depth and high mining volumes

2| Special cutting drum developed for the windrowing process with high, slender holder bases but without conveying helices for minimum energy requirements

3| Intelligent cutting tool arrangement for a minimum content of fines and low cost of wear

4| Specially designed edge segments for reduced face wear of the edge segments

5| Increased, heavy-duty cutting drum housing fully welded at the front for low wear and tear in tough operating conditions

6| Larger openings in the scraper blade and additional baffle plates to optimize the flow of large quantities of rock

7| Water spray bars in front of and behind the cutting drum assembly to reduce the development of dust

8| Rubber aprons at the scraper to ensure optimal sealing of the cutting drum assembly

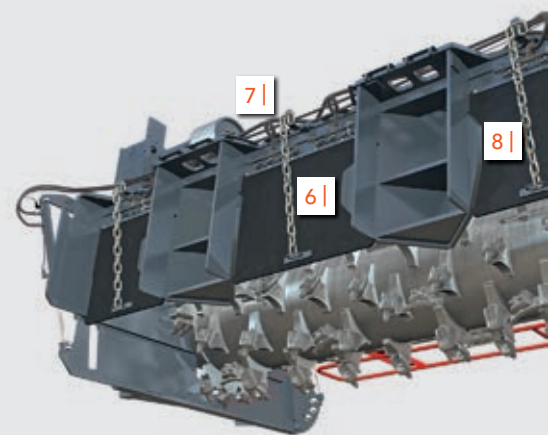

DESIGNED FOR TOP PERFORMANCE

The robust, 3.8-m wide cutting drum assembly is based not only on field-proven components but also on concepts developed specifically for the highly productive mining of soft rock. The cutting drum housing consists entirely of highly wear-resistant material. Effective closure of the drum assembly on the left and right is ensured by two hydraulically lifting side plates. The integrated water spray system reduces dust development when cutting dry useful minerals. Three large material dis-

charge openings in the scraper blade allow large amounts of material to be deposited in three windrows behind the machine.

Different types of highly wear-resistant mining tools cut rock with unconfined compressive strengths of up to 35 MPa. Ready access to the cutting drum and the hydraulic drum turning device additionally allow for easy tool replacement.



A cutting width of 3.8 m and cutting depth of up to 350 mm guarantee high mining volumes.



A worker in a high-visibility vest is operating a truck in a large, modern building with a glass and steel ceiling. The worker is visible through the truck's window. The truck is positioned in the lower left corner of the frame, and the ceiling structure is a complex grid of white panels and steel beams, creating a sense of depth and scale. The overall scene is brightly lit, emphasizing the industrial and architectural details.

The benchmark in operation.

BE RELAXED AND COMFORTABLE DURING WORK WHILE KEEPING EVERYTHING IN FULL VIEW - A GIVEN WITH THE 2200 SM 3.8. CLEARLY STRUCTURED CONTROLS ARRANGED IN LINE WITH ERGONOMIC PRINCIPLES. PROVIDING THE OPERATOR WITH ALL RELEVANT PARAMETERS AT A SINGLE GLANCE. THE INTELLIGENT VISIBILITY CONCEPT COMES AS STANDARD. WITH THE 2200 SM 3.8, YOU ARE IN FULL CONTROL. EASE OF HANDLING AND HIGH PRODUCTIVITY BECOME ONE.



Ample space, ergonomic design, comfort features and good visibility to both sides thanks to large glass windows ensure high operator comfort.

Work at ease and in a protected environment

RELAXED WORKING BOOSTS PRODUCTIVITY

Inside the cabin, the operator is protected from outside influences such as extremely high or low temperatures, wind, rain, dust, vibrations or high noise levels. The spacious, anti-vibration mounted cabin is soundproof and features a heating and air-conditioning system. These comfort features prevent fatigue and allow productive working for extended periods of time. Relaxed working is, of course, also promoted by good visibility and ease of operation. To provide a full view of the working area, the cabin features large glass

windows and extends beyond the sides of the machine on the left and right.

At the same time, the operator has a good view to both sides and immediate access to the controls. Both control panels can be moved far to the left or right and adjusted individually. In addition, the miner is equipped with LEVEL PRO, the electronic automatic levelling system for cutting depth control which quickly and precisely corrects any changes in the reference plane.



1 | Operation from the left or right: the two identical control panels have a small number of buttons and switches and can be separately adjusted in height, pivoted or moved to either side.

2 | Special sealing profiles provide optimal sealing of the cabin's upper and lower sections as well as of the cabin door.





More control

in off-road operation.

EXPERIENCE HAS SHOWN THAT THE TERRAIN OF LARGE-SCALE MINING OPERATIONS HOLDS UNEXPECTED DIFFICULTIES, SOME OF THEM PRESENTING A TRUE CHALLENGE. GOOD TO BE PREPARED FOR JUST SUCH A SITUATION. THE WIRTGEN 2200 SM 3.8 SURFACE MINER FEATURES MANY TECHNICAL INNOVATIONS HELPING YOU TO REACH YOUR GOAL SAFELY AND QUICKLY. MORE TRACTION, MORE MANOEUVRABILITY, MORE GROUND CLEARANCE. GIVING YOU MORE CONTROL AND MORE PRODUCTIVITY.

Highly manoeuvrable and robust in a tough environment

MAINTAINING MAXIMUM TRACTION

1 | *The reinforced machine frame and heavy counter-weight at the front provide machine stability in tough mining operations.*

2 | *Three different steering modes optimize manoeuvrability in restricted space conditions.*

The 2200 SM 3.8 features a finger-light hydraulic all-track steering system which provides the four track units with large steering angles. The advantages are obvious, especially when working in restricted space conditions: the inner turning radius of only 2.5 m and crab steering mode allow fast manoeuvring. In addition, separately height-adjustable track units ensure high ground clearance: they facilitate operation on uneven ground, reverse travel or machine loading. An engage-

able hydraulic differential lock additionally provides optimum traction regardless of ground conditions. The miner's operating and travel speeds are continuously adjustable. The 2200 SM 3.8 also features an amazingly high climbing ability and tremendous longitudinal inclination which enable it to be used for operations in difficult peripheral areas or for the production of separate access roads and ramps in the mine.

The components exposed to exceptionally high levels of wear and tear in the tough mining environment have additionally been given an even more robust design: the track units have undergone a complete redesign and pay for themselves quickly by a significantly extended service life. The machine frame has been reinforced especially at the pulley housing and at the connection to the cutting drum unit to optimize the stability of the miner. The supplementary weight, which has been increased by 400 kg, ensures perfect weight distribution at the front of the machine.



OPTIMIZATION OF THE FOUR TRACK UNITS



- | | |
|----------------------------|----------------------------|
| 1 Massive track frame | 4 Reinforced track pads |
| 2 Reinforced chain links | 5 Heavy-duty guide wheel |
| 3 Larger drive wheel | 6 Larger track pad bolts |

3 | "Clipped corner": chamfered track pad edges extend the lifespan of the bolted connections.

4 | Wear-resistant inner and outer baffle plates additionally extend the service life of the two rear track units.







Ready to deliver

full performance - always.

ROBUST DESIGN. EXTENDED SERVICING INTERVALS. INTELLIGENT MAINTENANCE. FEATURES COMBINING INTO ONE HALLMARK OF YOUR 2200 SM 3.8: HIGH OPERATIONAL AVAILABILITY. MORE IS REQUIRED, HOWEVER, TO ENSURE EFFICIENT 24/7 OPERATION. OPERATING ON A GLOBAL SCALE, THE WIRTGEN GROUP IS YOUR RELIABLE PARTNER AND ALWAYS AT YOUR SERVICE. PROVIDING CUSTOMER-SPECIFIC SUPPORT AND SUSTAINABLE SERVICE CONCEPTS, WE SUPPORT YOU ON YOUR ROAD TO SUCCESS.

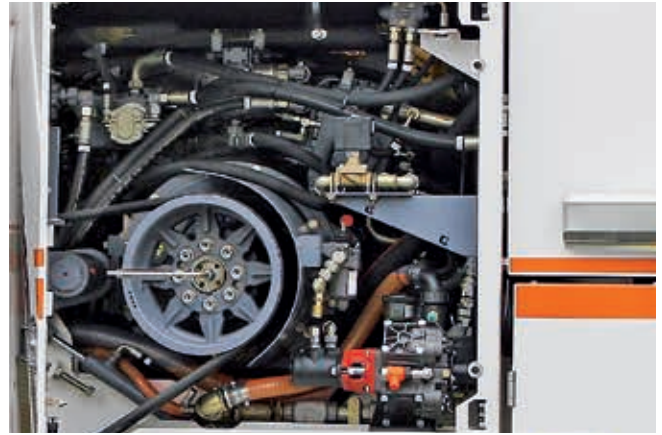
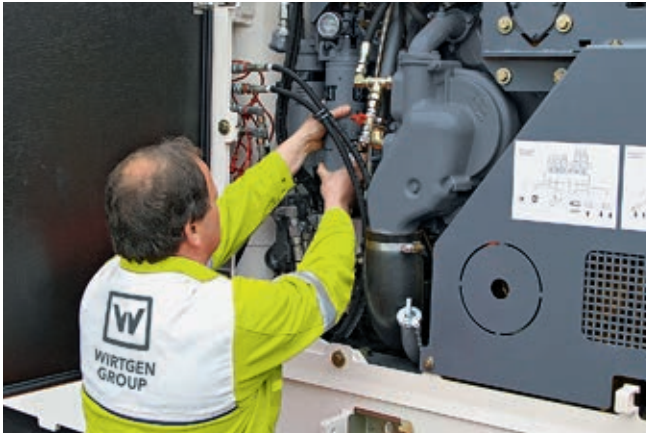

Maintenance is no problem at all as the entire machine offers ready access.

Ease of maintenance in a tough environment

ENGINE POWER USED EFFICIENTLY

In tough mining operations, the mechanical cutting drum drive with power belts stands out for its high efficiency. Changing the belt pulleys allows for two different cutting speeds. The almost loss-free transmission of power guarantees highest efficiency and top-of-the-range daily production rates while keeping maintenance simple. In addition, the high-performance diesel engine unleashes tremendous power when it counts. An intelligent machine management system controls the miner's advance rate fuel-efficiently and in accordance with the engine load.

All points of maintenance are arranged in a clear pattern and offer ready access. A separate access allows the cabin air filters, which are installed in optimal locations above the 2200 SM 3.8's cabin, to be replaced quickly and easily. The engine cowling can be opened hydraulically and offers ideal access to the fully soundproofed engine compartment.

The air filters have been installed in an extra-high position - where the air is cleanest - and as far away as possible from the exhaust system. Non-stressed mounting of the exhaust system guarantees a long life of the system components.



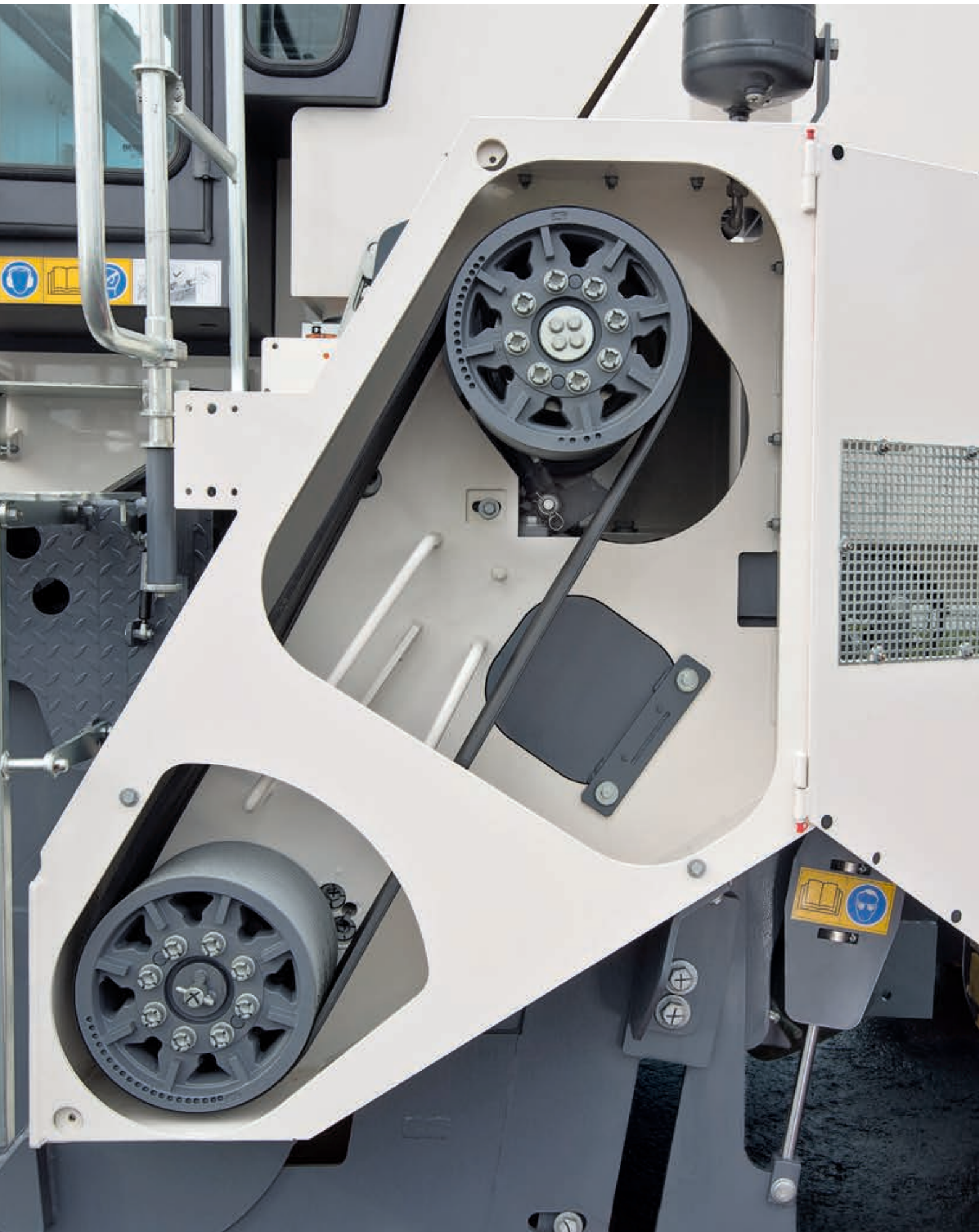

Technical specification

Cutting drum	
Cutting width, max,	3,800 mm
Cutting depth with conveyor system in windrowing mode* ¹	0-350 mm
Number of cutting tools	100
Drum diameter with tools	1,300 mm
Engine	
Manufacturer	Caterpillar
Type	C27 ATAAC
Cooling	water
Number of cylinders	12
Rated power at 2,100 r.p.m	708 kW/950 HP/963 PS
Fuel consumption, full load	187 l/h
Fuel consumption, ² / ₃ load	125 l/h
Emission standards	no EC regulation / US Tier 2
Electrical system	
Electrical power supply	24 V
Tank capacities	
Fuel tank	1,400 l
Hydraulic fluid tank	550 l
Water tank	5,000 l
Driving properties	
Operating and travel speed	0-84 m/min (0-5 km/h)
Theoretical gradeability	90%
Max. longitudinal inclination of machine when operating at upward or downward slopes	25%
Ground clearance	370 mm
Crawler units	
Crawler units front and rear (L x W x H)	2,200 x 370 x 790 mm
Shipping dimensions	
Machine without cutting drum assembly (L x W x H)	9,340 x 2,800 x 3,000 mm
Upper part of operator's cabin (L x W x H)	2,550 x 3,300 x 1,500 mm
Roll bar (L x W x H)	6,400 x 2,240 x 1,637 mm
Cutting drum assembly 3,800 mm (L x W x H)	4,570 x 2,800 x 2,150 mm

*¹ = The maximum cutting depth may deviate from the value indicated, due to tolerances and wear

Weight of base machine	
Empty weight of machine without filling media	50,350 kg
Operating weight, CE * ²	53,500 – 61,500 kg
Transport weights of individual components	
Weight of upper part of operator's cabin	1,300 kg
Weight of cutting drum assembly 3,800 mm	18,000 kg
Weight of roll bar	1,450 kg
Additional weight, front	4,700 kg
Weights of operating agents	
Water tank filling in kg	5,000 kg
Diesel tank filling in kg (0.83 kg/l)	1,160 kg
Optional equipment features increasing / reducing empty weight	
Driver and tools	
Driver	75 kg
On-board tools	30 kg
Optional additional equipment	
Canopy	280 kg
Fully enclosed operator's cabin	2,320 kg
Low-temperature kit	1,130 kg
Additional weight, rear	2,500 kg

*² = Weight of machine with half-full water tank, half-full fuel tank, driver (75 kg) and on-board tools, excluding optional equipment

Dimensions

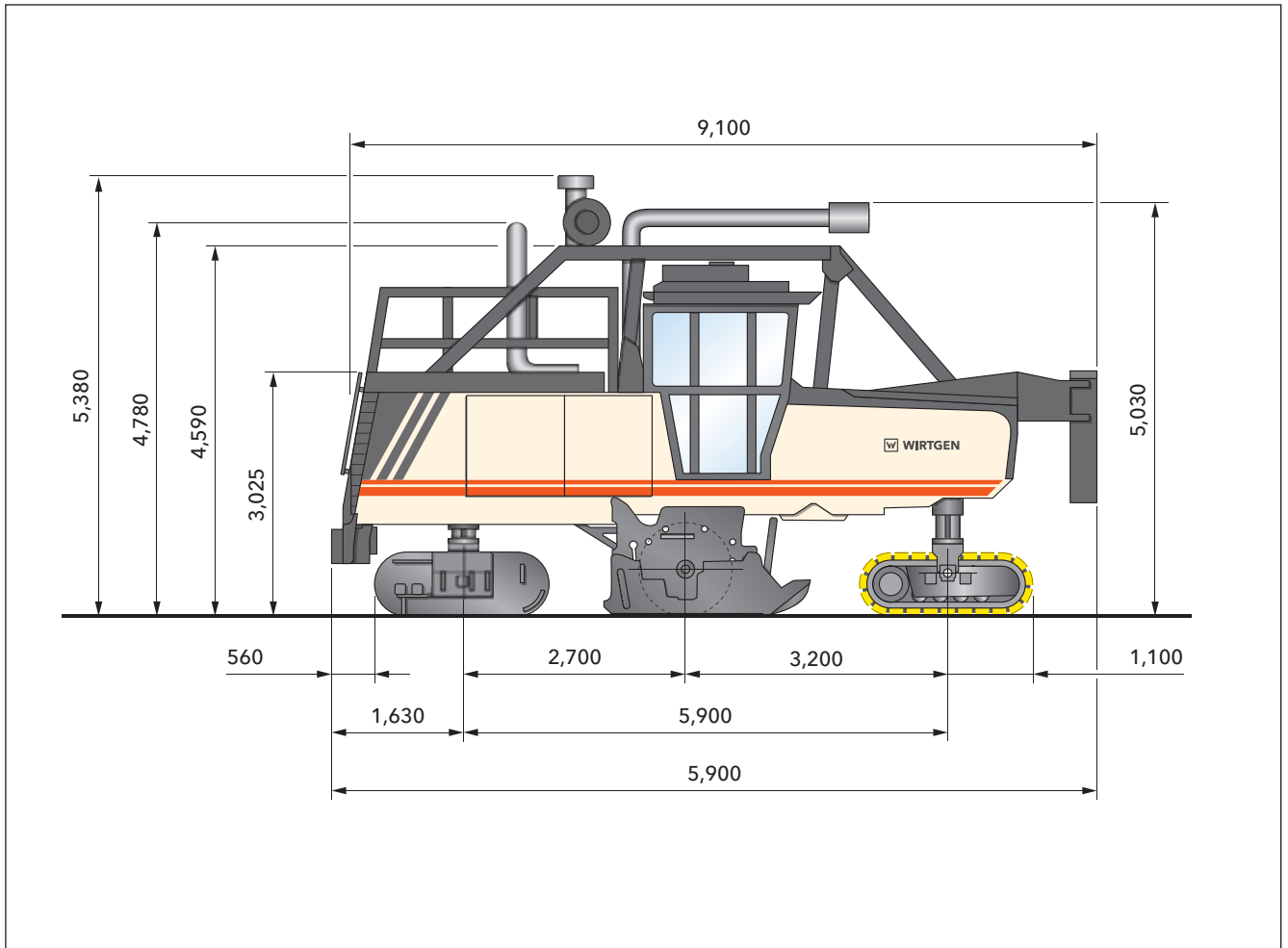

Dimensions in mm

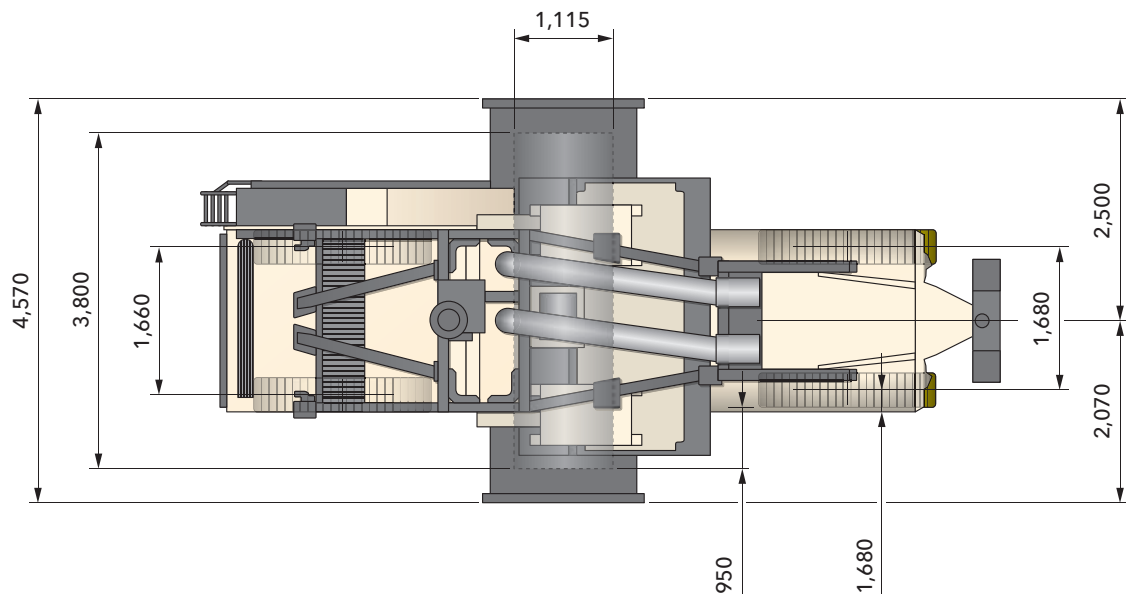

Dimensions in mm

Standard equipment

Base machine	
Basic machine with engine	■
Engine-air-intake with cyclone preliminary separator	■
Radiator with temperature-dependent fan speed	■
Lockable, hydraulically opening engine cover with integrated soundproofing	■
Mechanical cutting drum drive via three drive belts (total 15-groove) with automatic belt tensioner	■
Cutting drum unit	
Cutting drum housing completely made from wear-resistant material (HB400)	■
Two possible cutting speeds by exchanging drive belt pulleys	■
Cutting drum housing FB3800 - Surface Miner	□
Cutting drums	
Cutting drum FB3800 HT6 LA50 with picks	□
Material loading	
WINDROW equipment FB3800 for depositing milled material behind the machine	□
Machine control and levelling system	
Advance control across the entire speed range via joystick with proportional control characteristics	■
No need to change over between cutting and travelling gear	■
Automatic power controller for optimum power adaptation to different cutting conditions	■
Cutting depth regulation with LEVEL PRO levelling system, with one operating display and one wire-rope sensor each on right and left side plate	■
Operator's stand	
Continuous operators stand with one control panel each on right and left and two adjustable seats	■
The control panels are adjustable in height and angle, as well as movable from side to side	■
A multi-function display is permanently installed in the right control panel	■
Ladders to the operator's stand on the right and left (only left on version with cabin)	■
Two mirrors at front and one mirror at rear	■
Operator's stand standard version Surface Miner	□

- = Standard equipment
- = Standard equipment, replaceable with optional equipment
- = Optional equipment

Chassis and height adjustment	
Crawler units with particularly robust 2-web track pads in heavy-duty version for mining applications	■
Infinitely variable, hydraulic four-track drive with hydraulic differential lock	■
Proportional valve technology for the height adjustment	■
Four-track steering	■
The following steering types can be preselected: Crab and coordinated steering as well as straight ahead for the rear crawler units	■
Others	
Water sprinkling strip in the cutting drum unit	■
Light package with 5 headlights	■
Total of 6 EMERGENCY STOP switches at sensible positions on the machine	■
Lockable tool box with set of tools for maintenance and servicing	■
European type test certificate, GS mark and CE conformity	■
Temperature version standard	□
Water filling front - without filling pump	□
Paint standard cream white RAL 9001	□

■ = Standard equipment
 ■ = Standard equipment, replaceable with optional equipment
 □ = Optional equipment

Optional equipment

Cutting drum unit	
Transport carriage for milling drum units from FB2200 to FB4400	<input type="checkbox"/>
Material loading	
Additional double air horn at the top end of the discharge conveyor for signalling purposes.	<input type="checkbox"/>
Supporting device discharge conveyor	<input type="checkbox"/>
Framework semitrailer for discharge conveyor	<input type="checkbox"/>
Machine control and levelling system	
Turning angle sensor with connection cable	<input type="checkbox"/>
Sonic-Ski-sensor with connection cable	<input type="checkbox"/>
Ultrasonic sensor for scanning left	<input type="checkbox"/>
Wire-rope sensor for scanning ahead of the cutting drum right	<input type="checkbox"/>
Operating display LEVEL PRO additionally	<input type="checkbox"/>
Multiplex changeover box	<input type="checkbox"/>
Multiplex 3-way right with 2 ultrasonic sensors	<input type="checkbox"/>
Multiplex 3-way right + left with 4 ultrasonic sensors	<input type="checkbox"/>
Basic equipment laser levelling without laser transmitter	<input type="checkbox"/>
Machine slope control sensor	<input type="checkbox"/>
Monitor system with 2 cameras and monitor for machine with discharge conveyor	<input type="checkbox"/>
Monitor system with 2 cameras and monitor for machine without discharge conveyor	<input type="checkbox"/>
Operator's stand	
Weather canopy hydraulically lowering	<input type="checkbox"/>
Operator's stand with cabin - Surface Miner	<input type="checkbox"/>
Radio system complete	<input type="checkbox"/>

- = Standard equipment
- = Standard equipment, replaceable with optional equipment
- = Optional equipment

Others	
Low-temperature version down to -20° C/ -4° F	<input type="checkbox"/>
Water tank filling with hydraulic filling pump	<input type="checkbox"/>
High-pressure water cleaner with water filling front	<input type="checkbox"/>
High-pressure water cleaner with hydraulic filling pump	<input type="checkbox"/>
Paint in one special colour (RAL)	<input type="checkbox"/>
Paint in two special colours (RAL)	<input type="checkbox"/>
Paint in maximum two special colours with substructure in special colour (RAL)	<input type="checkbox"/>
Additional weight 2,500 kg on the rear of the machine	<input type="checkbox"/>
Cutting drum rotation device XXL cutting drum unit	<input type="checkbox"/>
Pneumatic hammer with pick ejector/insertor	<input type="checkbox"/>
Electrical diesel suction and pressure pump (50 l/min) with 7.50 m suction hose	<input type="checkbox"/>
Wiggins device for fast filling of the diesel tank	<input type="checkbox"/>

= Standard equipment
 = Standard equipment, replaceable with optional equipment
 = Optional equipment







WIRTGEN GmbH

Reinhard-Wirtgen-Str. 2 · 53578 Windhagen · Germany
Phone: +49 (0)26 45/131-0 · Fax: +49 (0)26 45/131-392
Internet: www.wirtgen.com · E-Mail: info@wirtgen.com

