

# EH3500AC-3



## DUMP TRUCK

Model Code : EH3500AC-3

Nominal Payload with Standard Equipment : 181 tonnes (200 tons)

Target Gross Machine Operating Weight : 322 000 kg

Engine : Standard : Cummins QSKTA50-CE

Rated Power 1 491 kW (2 000 HP)

Optional : MTU 12V4000 C21

Rated Power 1 510 kW (2 025 HP)

# Refined engineering and advanced Hitachi AC Drive system technology have created hauling capability well recognized in the surface mining industry.

The EH3500AC-3 continues to prove itself as an exceedingly capable and reliable solution to mine applications worldwide.



**Well Matched: EH3500AC-3 & Excavators**

Excavator	EX2600-6		EX3600-6		EX5600-6	
	BH	LD	BH	LD	BH	LD
Bucket	*17.0 m <sup>3</sup>	15.0 m <sup>3</sup>	*22.0 m <sup>3</sup>	21.0 m <sup>3</sup>	*34.0 m <sup>3</sup>	29.0 m <sup>3</sup>
Passes	6	7	5	5	3	3-4

BH : Backhoe LD : Loading shovel \* : SAE, PCSA heaped capacity

## AC Drive Proven Performance & Economic Advantages

Hitachi engineered AC drives make your hauler a more valuable asset in your mining operation. Better performance, higher availability, and significant reductions in maintenance and operating costs - result in a lower cost per tonne and a higher return on your investment.

## High-Powered Engine Selection

Standard Cummins QSKTA50-CE engine or optional MTU 12V4000 C21 engine is selectable for the market outside of North America. Within North America, choice is limited to the Cummins QSKTA50-CE engine.

## Long Frame Life

A fabricated box section and rectangular frame rail construction provides superior resistance to bending and torsional loads. The top and bottom flanges eliminate cross member tie-in joints and provide a larger exposed center area for access to major components.

## Tough Body

The Hitachi horizontal stiffener design minimizes stress concentrations by dissipating load shocks over the entire body length. Efficiently spaced stiffeners provide additional protection by minimizing distances between unsupported areas.



# AC Drive Advantage

Hitachi AC drive technology provides superior truck performance with higher top speeds, better gradeability and stronger electric braking. Hitachi inverter modules provide high rigid truck controllability and efficiency. The Hitachi AC wheel motors do not have commutators and brushes, which improves truck performance by providing reduced maintenance costs, higher truck availability and higher travel speeds. These advantages result in more productivity and lower costs per tonne. Hitachi AC drive systems also power electric train locomotives world wide.

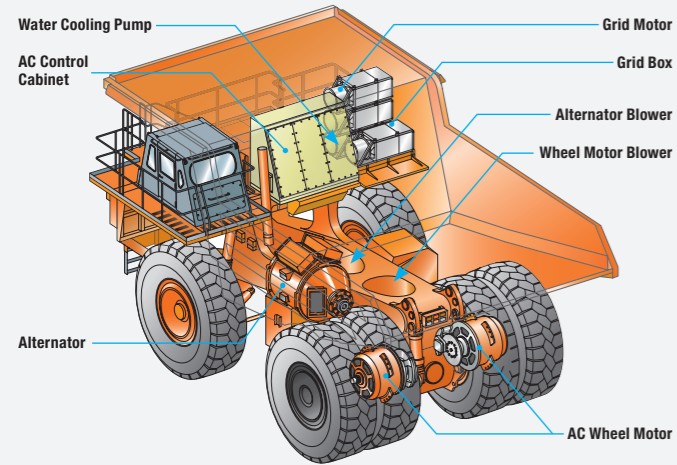

## Hitachi Drive Control System

New Hitachi drive control system for optimal operational stability and performance as follows.

### 1. Slip / slide control system

If the system senses slipping or locking of rear wheels when traveling on slippery or frozen roads, it adjusts the torques of the wheel motors accordingly, bringing the truck more stable traveling.

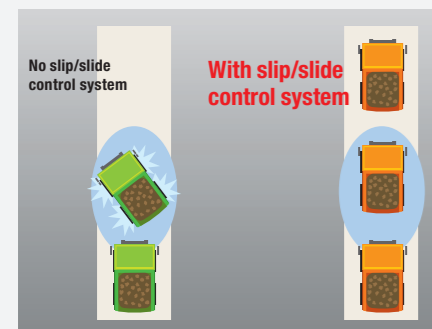

### 2. Pitch control system

If the system senses pitching when traveling on bumpy roads or stopping abruptly, it adjusts the torques of the wheel motors accordingly to reduce pitching of the truck, resulting in better operating comfort and fewer load spillage.

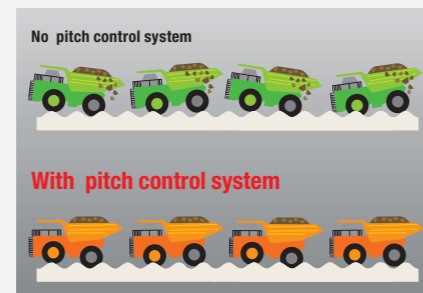

### 3. Side Skid control system

If the system senses oversteer or understeer from the newly equipped sensors, it adjusts the torques of the wheel motors accordingly to control the side skidding. This brings the truck smoother movements and more stable traveling and steering.

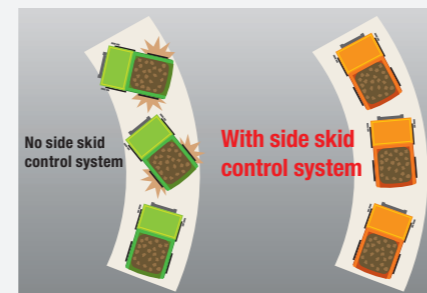

Note: This system is designed originally to enhance pleasant driving, so please drive at a safety speed or lower, and make periodic maintenance of the haul road.

## AC Drive Control

**Superior Electric Braking** enables the driver to stop the truck using the electric brake pedal only with the exception of emergencies, because the AC drive control system applies the service brakes automatically just before the stopping, resulting in easy machine operation and longer time between service brake maintenance intervals.

**Auto Cruise Control** keeps vehicle speed constant within the set range by limiting the minimum vehicle speed.

**Auto Retarding Control** keeps vehicle downhill speed constant within the set range by limiting the maximum vehicle speed.

## The AC Drive Wheel Motors

The Hitachi Double Path Tandem Planetary Design provides high efficiency. Better component and lubricant life is the result of holding the 1st carrier stationary and constantly cycling the lubricant through a cooler and filter.



# Ease of Operation

## HI-TECH ROPS/FOPS Cab

The HI-TECH ROPS/FOPS cab has been equipped with a Hitachi controller and a large centrally mounted, color Liquid Crystal Display (LCD) as used in Hitachi large sized excavators. Double wall construction of 11 gauge inner and outer steel panels produces a more structurally sound cab. A three-point rubber isolation-mount arrangement minimizes vibration to the operator compartment.



Note: This image shows a monitor for optional SkyAngle at the left pillar.



## Superior Suspension

The Hitachi trailing arm suspension system delivers excellent maneuverability, even at higher speeds. The trailing arm layout offers greater ease of servicing while improving truck performance compared to suspended king-pin designs. The pivot mounting of the trailing arm design allows only axial input to the strut and allows wheel movement to the vertical plane only.

### Features:

- Lateral forces that act on the front wheels are minimized, resulting in reduced tire scuffing.
- Dynamic friction (side-wall force) within the strut is low due to the features of the trailing arm suspension design, allowing the use of a lighter strut engineered to a smaller diameter and longer stroke.
- The necessary frame bulk (horse-collar structure) needed to mount a suspended king-pin is non-existent.
- The elimination of the “horse-collar” member provides greater engine access.

- The NEOCON strut used with the trailing arm suspension, improves operator and component isolation, provides better hauler stability and predictable operational control.
- Locating the king-pin close to the wheel assembly and at a slight angle results in low “Dry Park Steering” effort.
- Development of the compressible media, NEOCON- E™ fluid (proprietary, silicone based, environmentally friendly) for use in the suspension strut with Helium gas, results in an improved energy absorption (isolation) system and an improved energy release (stability) system that responds favorably whether traveling empty or loaded in a wide range of ambient temperatures.

The trailing arm suspension design allows the front struts to be removed and installed without removing the front brakes or tires. This means fewer tools and less labor time are required, resulting in less downtime and higher productivity.

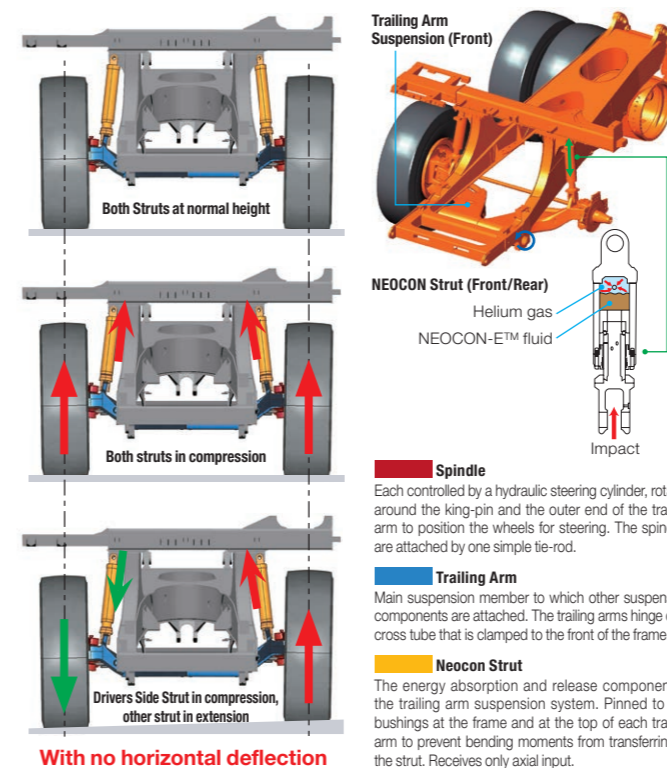

## THE FAST FILLING SYSTEM

The fast filling system, provided standard on the left side of the radiator, allows direct access at ground level for fast feeding of coolant, grease, hydraulic oil and engine oil. (Couplers are optional.)

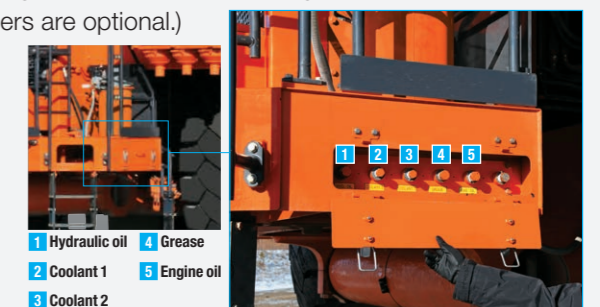

## Simplified Maintenance



### Low Maintenance Air filters with evacuator valves

Four Air filters with evacuator valves bring easy and safe maintenance.



### Ground Level Battery Box and Relay Box

The battery box door with gas cylinders allows the operator safe and easy maintenance.



### Collapsible Step for Maintenance inside Rear Axle

The collapsible step and flat service stage inside rear axle bring higher serviceability and safety.

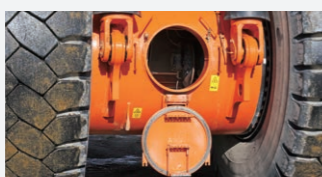

### Remote Machine Management with Global e-Service

This on-line machine management system allows you to access each on-site machine from a PC in your office. You can get its operating information and location to increase productivity. Operating data and log are sent to a Hitachi server for processing, and then to customer and dealers. This system is available 24 hours a day, all the year around.

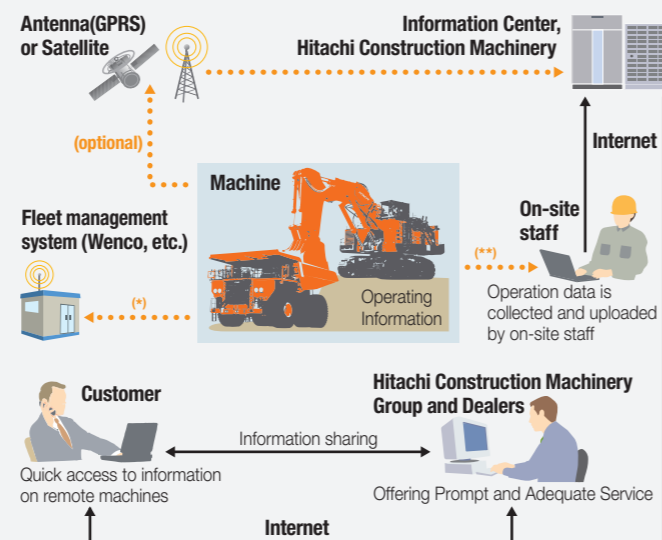

Note : In some regions, Global e-service is not available by local regulations.  
 \* DTU (optional) and fleet management system contract are required.  
 DTU : Data Transfer Unit  
 \*\* WIU (optional) to transmit operating data for wireless collection is required.  
 WIU : Wireless Interface Unit

## SkyAngle™ (Optional)

### Hitachi Dump Truck with Peripheral Vision Support System

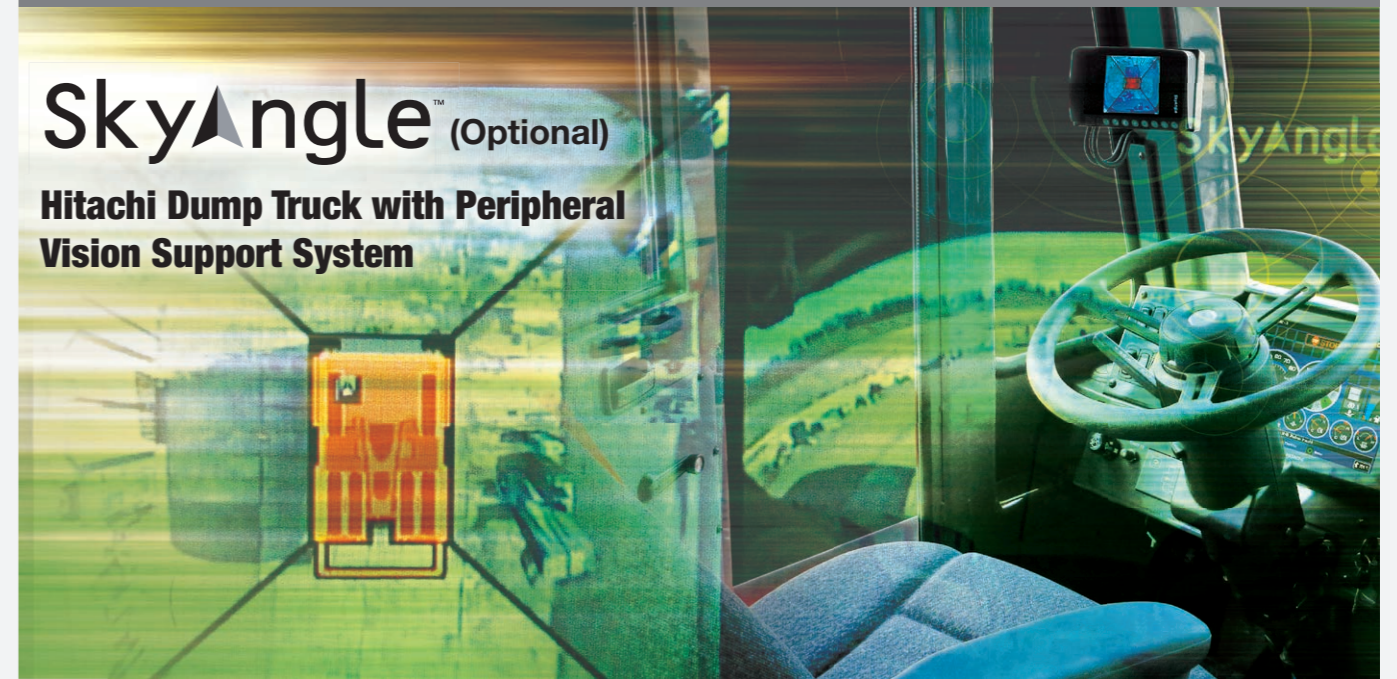

### Camera Monitor

A Camera Monitor for SkyAngle is located on the left-front pillar of the cab. A Screen Changeover Switch is located on the left hand side of the console.



Camera Monitor for SkyAngle



Screen Changeover Switch



### Locations of the Cameras & Viewing Angles

The SkyAngle feature is available to significantly increase peripheral vision around the dump truck by providing synthesized multiple images captured by cameras specifically positioned at 4 locations around the truck.

The feature displays camera views on a single monitor to allow operators an auxiliary means of checking for ground level obstacles.

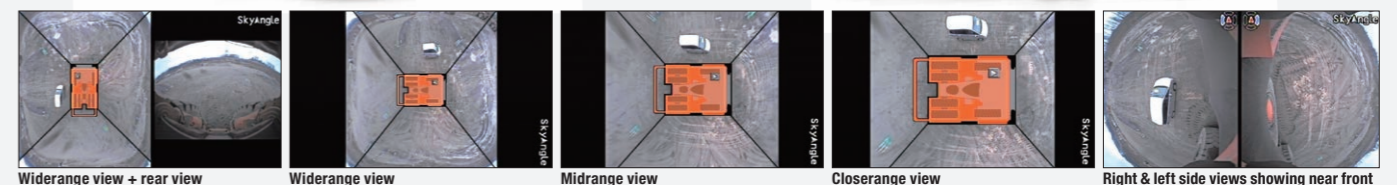

Widerange view + rear view

Widerange view

Midrange view

Closerange view

Right & left side views showing near front tires (available on neutral or forward only)

# SPECIFICATIONS

## ENGINE

### Standard

Model .....	Cummins QSKTA50-CE
Type .....	4 Cycle Diesel w/ MCR fuel system
Aspiration .....	2 stage Turbocharged & Low Temperature Aftercooled
Emission Certification .....	U.S. EPA Tier 2
Gross Power @1900 min <sup>-1</sup> (rpm)	
SAE J1995 .....	1 491 kW (2 000 HP)
Net power @1900 min <sup>-1</sup> (rpm) ...	1 398 kW (1 874 HP)
Maximum Torque @1 500 min <sup>-1</sup> (rpm)	
SAE J1995 .....	7 871 N.m (803 kgf.m)
No. of Cylinders .....	16
Bore & Stroke .....	159 x 159 mm
Displacement .....	50.3 L
Starting .....	24 Volt Electric

### Optional

Model .....	MTU 12V4000 C21
Type .....	4 Cycle Diesel w/ DDEC
Aspiration .....	1 stage Turbocharged & Low Temperature Aftercooled
Emission Certification .....	Not Certified
Gross Power @1900 min <sup>-1</sup> (rpm)	
SAE J1995 .....	1 510 kW (2 025 HP)
Net power @1900 min <sup>-1</sup> (rpm) ...	1 417 kW (1 900 HP)
Maximum Torque @1 500 min <sup>-1</sup> (rpm)	
SAE J1995 .....	8 199 N.m (836 kgf.m)
No. of Cylinders .....	12
Bore & Stroke .....	165 x 190 mm
Displacement .....	48.8 L
Starting .....	24 Volt Electric

## ELECTRIC DRIVE

### HITACHI AC-Drive System

#### AC Control Cabinet

Rectifier	
Number of units .....	1
Rated capacity .....	1 340 kW
IGBT Inverter	
Number of units .....	2
Rated capacity per unit .....	800 kVA
Chopper	
Number of units .....	2
Rated capacity per unit .....	1 300 kW

Equipped with reliable water cooling system. Pressurized cabinet to reduce dust. Equipped with lockable doors for safety. Equipped with small inverters to provide Grid motors and Blower motor with adequate AC current. Uniquely constructed for the Rigid Truck application

#### Alternator

Number of units .....	1
Capacity .....	1 500 kVA at 1 900min <sup>-1</sup> (rpm)
Equipped with an auxiliary alternator that provides AC current to Grid motors, Blower motors, and Control cabinet coolant pump. Air cooled by an AC drive blower.	

#### AC Wheel Motor

Number of units .....	2
Capacity per unit .....	620 kW
Air cooled by an inverter controlled AC drive blower.	

#### Grid Box (Electric Brake)

Number of modules .....	4
Capacity per unit .....	625 kW (3 min.)
Equipped with inverter controlled variable speed cooling fan.	

#### Axle

Planetary Ratio .....	35.2 : 1
Maximum Speed (Continuous)....	56 km/h

## TIRES

### Front and Rear

37.00R57 (standard) .....	736.6 mm (29 in)
40.00R57 .....	736.6 mm (29 in)

### Rim Width

Tire manufacturers offer tires having a range of capabilities suitable for a variety of applications. For high performance hauling it is important to consult with the tire manufacturer to choose a tire that is best matched to truck TGMOW, travel speed and customer specific jobsite conditions. Jobsite condition severity, may result in a reduced truck payload and travel speed recommendation.

## ELECTRICAL SYSTEM

Twenty-four volt system. 140 ampere Cummins engine driven or 260 ampere MTU engine driven alternator. Four 245H52, 12 volt, heavy duty batteries connected in series/parallel.

## BODY CAPACITIES

Struck (SAE) .....	80.4 m <sup>3</sup>
Heaped 3:1 .....	105 m <sup>3</sup>
Heaped 2:1 (SAE) .....	117 m <sup>3</sup>

Body capacity and payload subject to change based on customer specific material density and application.

## STEERING SYSTEM

Closed-center, full time hydrostatic power steering system using two double-acting cylinders and a variable displacement piston pump. Hitachi accumulators provide supplementary steering in accordance with ISO 5010 (SAE J1511), supplying a constant steering rate under all conditions. A tilt/telescopic steering wheel with 35 degrees of tilt and 57 mm telescopic travel is standard.

Turning Diameter (ISO 7457) .....	29.3 m
-----------------------------------	--------

## HYDRAULIC SYSTEM

Two (2) Hitachi three-stage, double-acting cylinders, with electronic controlled cushioning in retraction and extension, containing dual rod seals and urethane energized scrapers, inverted and outboard mounted. A tandem piston pump combines with four position electronic pilot controlled hoist valve. The electrical controller is mounted to the shift tower.

Body Raise Travel .....	59.0 degrees
Body Raise Time .....	17.5 sec
Body Down Time (Float) .....	15.0 sec

## BRAKE SYSTEM

Brake system complies with ISO 3450 (SAE J1473).

### Service Brake

Service braking for the EH3500AC-3 is made up of front and rear hydraulically applied brakes and the electric brake.

#### Front Axle – Dry Disc

Disc Diameter Each (2 discs/axle, 3 calipers/disc) .....	121.7 cm
--	----------

#### Rear Axle – Dry Disc

Disc Diameter Each (2 discs/axle, 3 calipers/disc) .....	109 cm
--	--------

### Secondary

Two of front hydraulic, rear hydraulic and electric brake within the service brake system provide modulated reserve braking capability. Both front and rear hydraulic brakes are automatically applied when loss of pressure is detected.

### Parking Brake

This system is designed to use spring applied, hydraulically released brake calipers to hold the truck stationary.

### Electric Brake

The Electric Brake is used for usual operating brake for the EH3500AC-3. The Hitachi AC Drive system provides all necessary truck speed control, including speed reduction to 0 km/h travel speed when the electric brake pedal is depressed. Also, the rear service brakes automatically apply at speeds below 0.5 km/h if this pedal is depressed.

Maximum dynamic braking (Standard) .....	2 800 kW
--	----------

### Load/Dump Brake Apply

Through activation of a switch by the operator, a solenoid is energized, sending full brake pressure to apply the rear Wet Disc brakes. For use during the load and dump cycles.

## WEIGHTS (Approximate)

Net machine weight stated below includes standard equipment. Net machine weight changes will directly affect the Nominal Payload.

### With Standard 37.00R57 Tires

Chassis with Hoist & Body parts .....	118 000 kg
Body excluding body parts .....	23 000 kg
Net Machine Weight .....	141 000 kg
The Net Machine Weight specification includes operator and 100 % fuel.	

Nominal Payload .....	181 tonnes
Target GMOW .....	322 000 kg

### Weight Distribution

	<b>Front</b>	<b>Rear</b>
Empty	48 %	52 %
Loaded	33 %	67 %

### With Optional 40.00R57 Tires

Chassis with Hoist & Body parts .....	123 000 kg
Body excluding body parts .....	23 000 kg
Net Machine Weight .....	146 000 kg
The Net Machine Weight specification includes operator and 100 % fuel.	

Nominal Payload .....	178 tonnes
Target GMOW .....	324 000 kg

### Weight Distribution

	<b>Front</b>	<b>Rear</b>
Empty	48 %	52 %
Loaded	33 %	67 %

### Note:

Body parts mean assembled standard parts to the body, such as mud guards, body pads, rock ejector bars and fasteners.

### Note:

The Nominal Payload specification is calculated using the Hitachi Loading Policy. Specific job site requirements may result in an adjustment to the Nominal Payload weight. Consult your Hitachi dealer for a truck configuration which will match your haulage application.

## HI-TECH ROPS/FOPS CAB

### New HI-TEC ROPS/FOPS Cab

ROPS complies with ISO3471 and SAE J1040-May 94, FOPS complies with ISO3449. A three-point rubber ISO-mount arrangement to the high-arch cross member minimizes vibration transfer to the operator compartment. New wider cab with double full size seat available and enough trainer's leg space brings comfortable operating and training.

### Monitoring System

A new Hitachi system monitor provides display information and diagnostics of all onboard systems and controls which include the engine and Hitachi AC drive. Data links offer complete integration, while a color Liquid Crystal Display (LCD) clearly details machine functions. Downtime is minimized with faster and more reliable troubleshooting and analysis. A new Hitachi load monitoring system offers benefits such as better equipment utilization on the jobsite, accurate unit and fleet production results, and benchmark unit statistics against fleet results. Cycle time, distance and cycle count can all be measured and recorded as information that can help in developing higher productivity. The Hitachi load monitoring system is fully integrated with the Hitachi vehicle monitoring system and display interface, avoiding potential failure or error common in aftermarket systems.

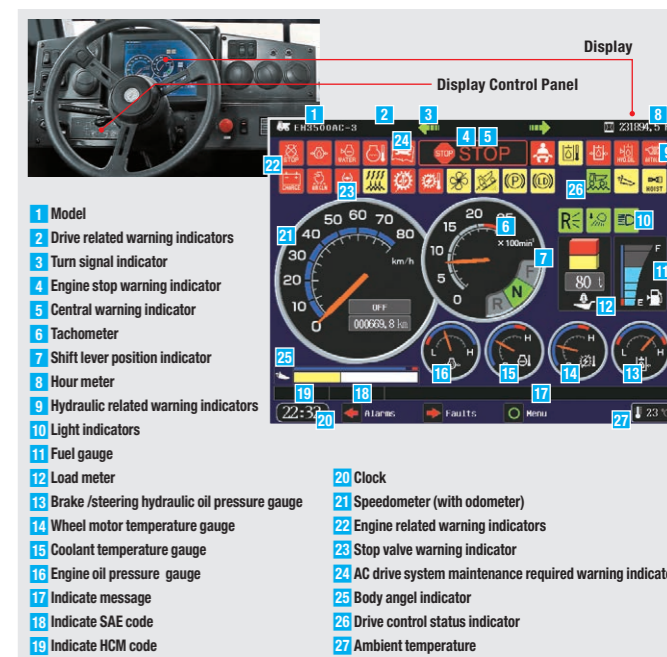

### Camera Monitoring System

Included as standard safety support equipment, an analog monitor has been mounted to the dashboard to display live camera information of the rear and right front area.

## SUSPENSION

### Front Suspension

Independent trailing arms make up the front axle. NEOCON struts containing energy-absorbing gas and compressible NEOCON-E™ fluid are mounted between the trailing arms and frame. Inherent in the NEOCON strut design is a variable damping and rebound feature.

### Rear Suspension

"A" frame structure, integral with axle housing, links the drive axle to the frame at forward center point with pin and spherical bushing. A track rod provides lateral stability between the frame and drive axle. Heavy-duty rear-mounted NEOCON struts containing energy-absorbing gas and compressible NEOCON-E™ fluid suspend the drive axle from the frame. Integral variable damping and rebound feature included.

# SPECIFICATIONS

## FRAME

Full fabricated box section main rails with section height tapered from rear to front. Narrow at the rear to support the load and wider at the front allowing truck stability and excellent engine access for servicing. One piece top and bottom flanges that eliminate cross member tie in joints and provide a large exposed center area for access to major components. Large radii at frame junctions are blended and ground to minimize stress concentrations. Weld joints are oriented longitudinally to the principal flow of stress for greater durability and more strength. The new "bolt-on" High Arch Design requires less assembling time and no welding. The design provides higher structural quality and better serviceability during engine overhaul.

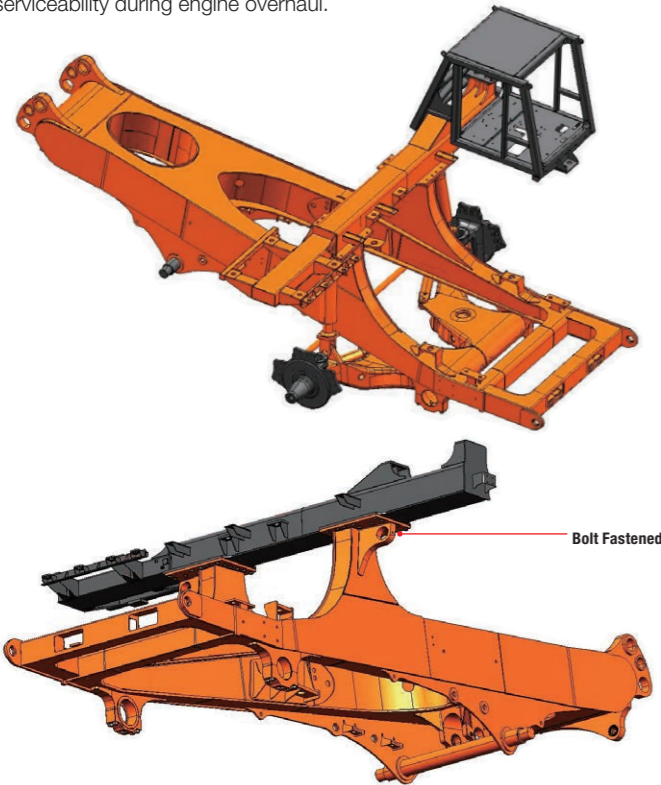

## BODY

An extended canopy protects service deck area. High tensile strength 400 BHN abrasion resistant alloy steel is used in thicknesses indicated below:

Floor.....	16 mm
Front.....	9 mm
Sides.....	9 mm
Canopy.....	6 mm
Corners.....	12 mm

High strength 690 N/mm<sup>2</sup> (100 000 psi) alloy steel is also used for the canopy side members and floor stiffeners. The body is rubber cushioned on the frame.

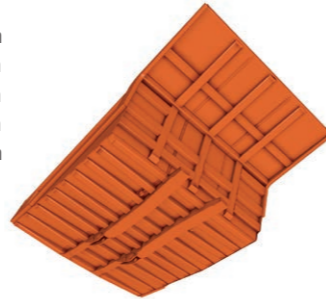

### Optional Body Liners

Floor & Corners.....	12 mm
Sides & Front.....	6 mm
Canopy drop edge.....	6 mm

Special plate thicknesses and partial plates are available.

## SERVICE CAPACITIES

Crankcase (includes filters): Cummins.....	200 L
Crankcase (includes filters): MTU.....	190 L
Engine Cooling System: Cummins.....	531 L
Engine Cooling System: MTU.....	543 L
Fuel Tank (Standard).....	2 040 L
Fuel Tank (Optional).....	3 690 L
Hydraulic system.....	750 L
Planetary Drives (L & R).....	218 L
Front Wheels (L & R).....	17 L
Windshield Washer.....	20 L
Main Accumulator.....	70 L

## HITACHI BODIES

### Tough Body Structure

Designed by Hitachi for long lasting strength and productivity. Hitachi offers customized solutions to match specific load and haul applications. Optional bodies and parts are engineered on request.

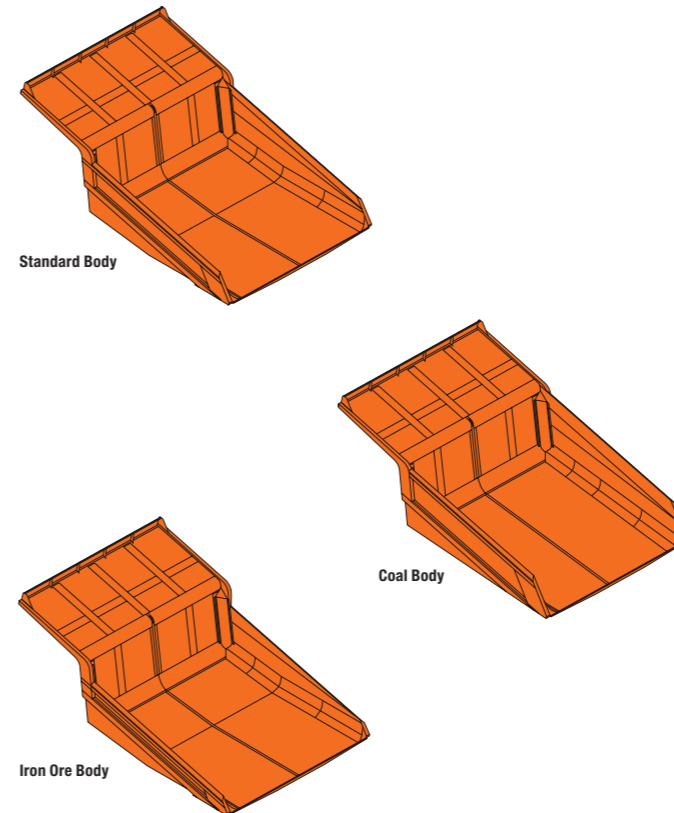

### Standard Body

The Hitachi standard body is designed to accommodate the needs of popular mid-range material densities and the most popular loading machines. Various options, such as liners, spill guard, extended canopy are available.

### Coal Body (Optional)

The Hitachi coal body has been designed for low material density, small fragmented, low abrasive material. This coal body offers excellent material shedding, low empty weight and large capacity.

### Iron Ore Body (Optional)

The Hitachi iron ore body has been designed for use in rugged iron ore mining applications. The body has been designed for high density material and optimized loading and dumping.

### Customized Body (Optional)

Upon request and approval, Hitachi will design bodies to suit special mining applications.

## HITACHI LOADING POLICY

### Operational Benefits

#### Haulroad Safety

Truck loading within the limitations of the Hitachi Loading Policy will result in designed and certified operational performance of the steering, brake and ROPS systems of the truck.\*

#### Efficient Productivity

Truck loading within the limitations of the Hitachi Loading Policy will result in optimizing the fuel economy and travel speed performance to which the truck was designed to.\*

#### Availability and Maintenance

Lower maintenance costs and higher availability can be achieved if truck loading is within the limitations of the Hitachi Loading Policy.\*

\*Hitachi recommended maintenance is required.

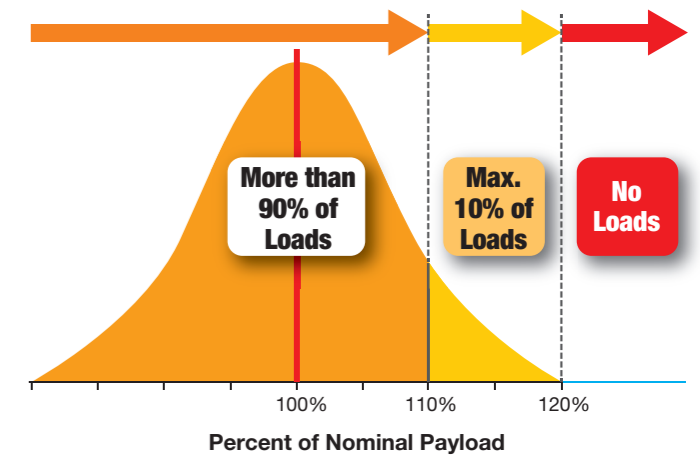

- 1: More than 90% of all loads must fall below 110% area (Orange area).
- 2: If necessary due to excessive variation in material density, loader bucket fill-factors or bucket sizes, loading the truck to between 110% and 120% of Nominal Payload is allowed if it accounts for less than 10% of all loads (Yellow area).
- 3: Loading above 120% of Nominal Payload is not allowed. (Red Area)

## PERIMETER VISIBILITY (STANDARD)

The addition of mirrors and cameras to the base model make the truck compliant to the perimeter viewing requirement of standards ISO 5006 and ISO 14401.

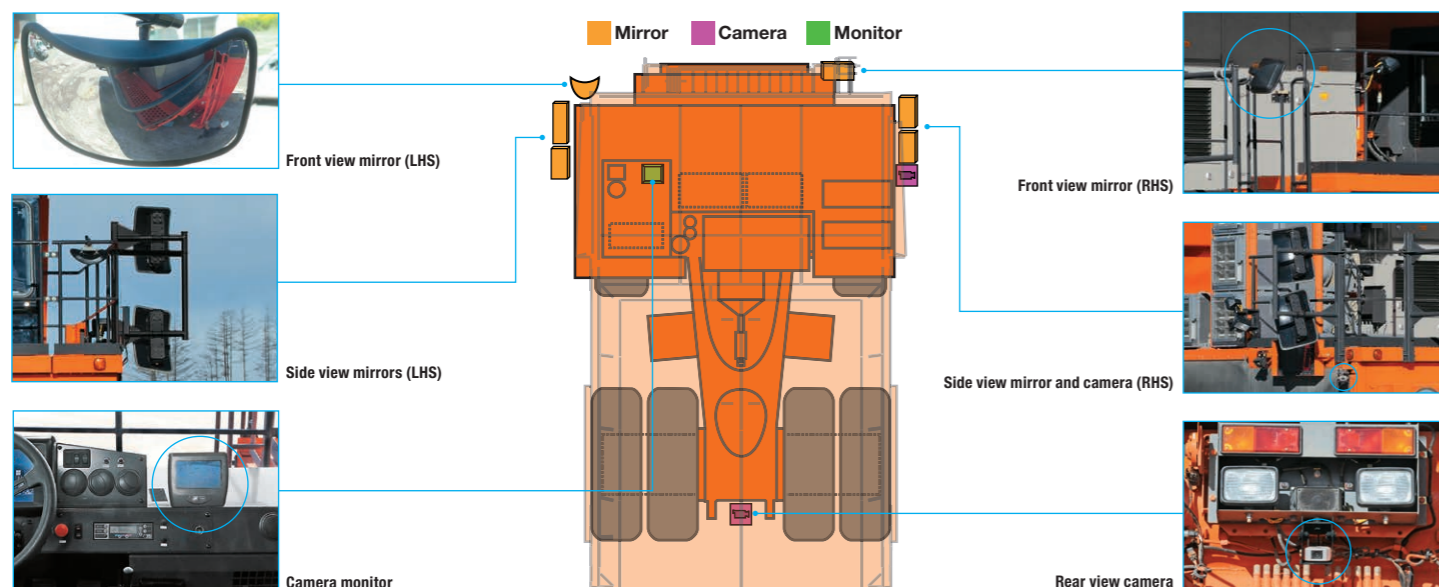

# DIMENSIONS

Unit: mm

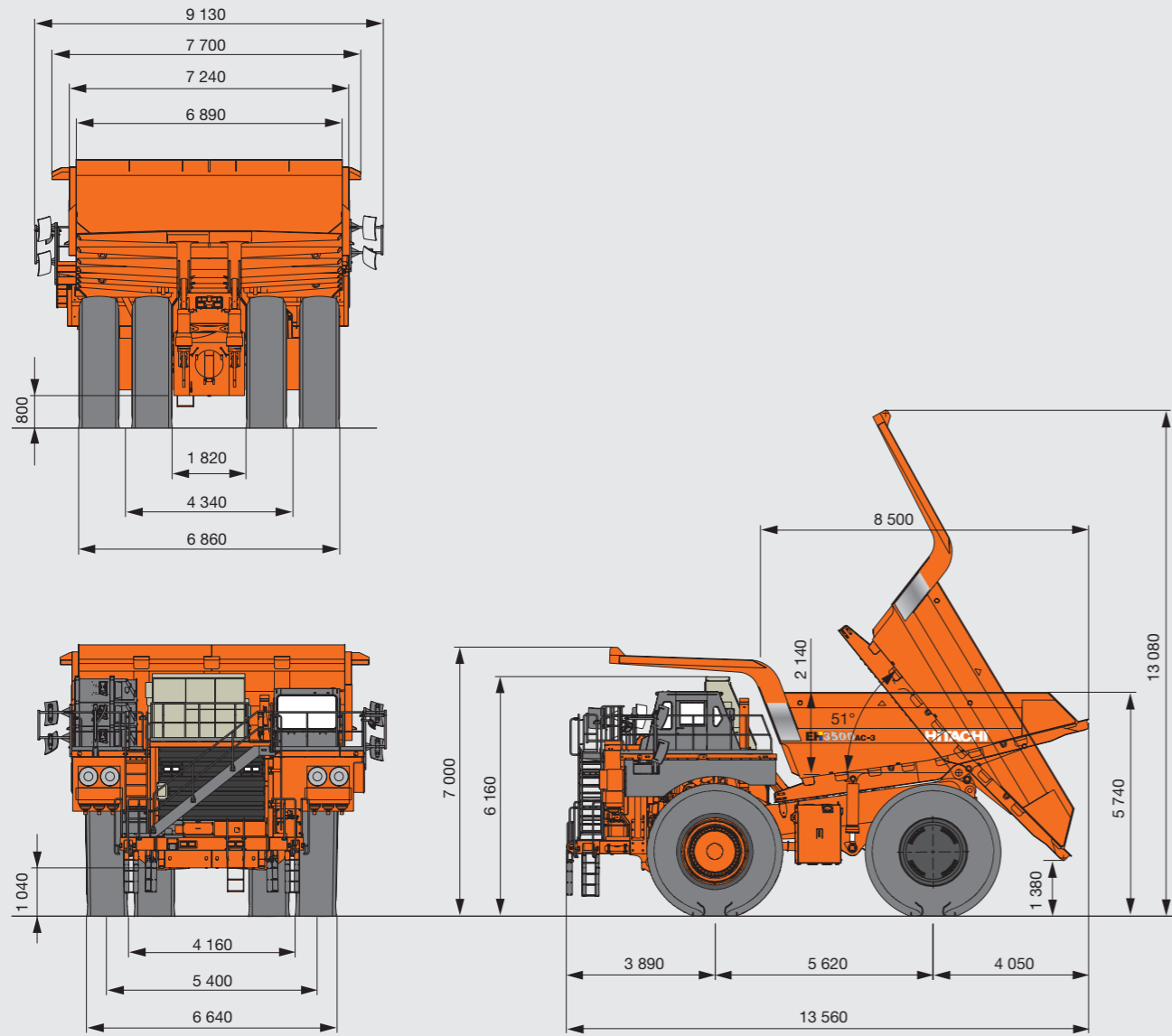

Note: Dimensions shown are for an empty machine with 37.00R57 tires.  
Exact dimensions may vary due to tire make, type, and inflation pressure.

# EQUIPMENT

## STANDARD EQUIPMENT

### GENERAL

AC drive system	Front view mirror, LHS/RHS
Auto cruise control	Fuel/Water separator
Auto retarding control	Fuel tank, 2 040 L
Automatic lubrication system (Lincoln)	Ground level battery box
Battery isolation switch	Ground level relay box
Blower fan motor for Alternator cooling (1)	IGBT controlled blower fan motor for Wheel Motor cooling (1)
Body prop cable	IGBT controlled grid fan motors (4)
Control cabinet pressurized/liquid cooled/ lockable	Load weighing system
Deck mounted muffler	Maximum speed control system according to payload
Deck mounted stone guards	NEOCON suspension struts
Diagonal front stairway	Rear view camera
Electric controlled hoist system	Rear view mirrors (4)
Electric horns (4)	Rims, 29 inch
Emergency ladders (2)	Side view camera (RHS)
Engine access ladders (2)	Suction port shut off valve at hydraulic tank
Engine shutdown switch Beside engine (2)	Supplementary front braking system, accumulator
Ground level, on bumper (1)	Supplementary rear braking system, accumulator
Inside rear axle (1)	Supplementary steering system, accumulator
Fan and belt guards	Tow hooks, front
Fan clutch	Tow lugs, rear
Fast fluid filling system	
Fast fuel filling system provision	
Final drive lubricant cooling	
Final drive lubricant filtration	

### CAB

Air conditioner	Override switch
FM radio	Seat with 2-point, 50 mm width seat belt
Auxiliary outlet, 12 volt	Full size operator's seat, air suspension & 6 position
Camera monitor	Regular size trainer's seat, mechanical & adjustable
Engine shutdown switch	Tinted safety glass, with roll-down windows
Heater and defroster	12 volt accessory connection
Integral ROPS/FOPS cab	
LCD system monitor	
Load and dump brake switch	

### INDICATORS AND GAUGES SHOWN ON MONITOR DISPLAY

AC drive system maintenance required warning indicator	Hour meter
Ambient temperature	Hydraulic related warning indicators
Body angel indicator	Indicate HCM code
Brake/steering hydraulic oil pressure gauge	Indicate message
Central warning indicator	Indicate SAE code
Clock	Light indicators
Coolant temperature gauge	Load meter
Drive control status indicator	Model
Drive related warning indicators	Shift lever position indicator
Engine oil pressure gauge	Speedometer (with odometer)
Engine related warning indicators	Stop valve warning indicator
Engine stop warning indicator	Tachometer
Fuel gauge	Turn signal indicator
	Wheel motor temperature gauge

### MACHINE LIGHTS

Backup lights (2)	Engine compartment lights (2)
Clearance lights (4)	Halogen headlights (8)
Combination stop and tail lights (2)	Payload external indicators, 2 locations of 2 lights each
Deck lights (2)	Rear axle compartment light
Diagonal front stairway light	

## OPTIONAL EQUIPMENT

Arm guard	Gridbox guard **
Auxiliary dump connection	Halogen front tire lights (2)
Auxiliary steer connection	Heated mirrors
Body liners (400BHN)	HID headlights (8)
Body prop pins	Loadweight displays (2)
Body sizes **	SkyAngle
Cold weather package **	Sound attenuation package **
Communication system (alternative) *	Spare rim
GPRS communication system	Tire guards (2)
Satellite data transmitting system	Trolley assist configuration **
Deck guard	WIU (Wireless Interface Unit) *
Fast fluid filling system couplers	
Fast fuel filling system coupler	
Fuel tank, 3 690 L	
Full size operator's seat, air suspension & 6 position, with 3-point, 50 mm width seat belt	
Full size trainer's seat, air suspension & 6 position, with 2-point, 50 mm width seat belt	

\* : The availability of the system depends on licensing regulations in each country. Please contact Hitachi dealer for more information.

\*\* : Engineered on request

## OPTIONAL EQUIPMENT WEIGHT

Body liners (400BHN) plates including floor & corners (12 mm thicknesses), sides & front and canopy (6 mm thicknesses)	6 870 kg
3 690 L fuel tank with 100 % fuel (additional weight to the standard tank with 100 % fuel)	2 000 kg
Arm guard	140 kg
Arm guard	100 kg
Loadweight display (2)	150 kg
Tire guard (2)	130 kg

Note: Regarding the Cummins engine, fuel optimized ratings available to meet worldwide emissions and enhanced fuel efficiency. Contact your nearest authorized Cummins Distributor for details and availability.





---

Before using a machine with a satellite communication system, please make sure that the satellite communication system complies with local regulations, safety standards and legal requirements. If not so, please make modifications accordingly.

---

These specifications are subject to change without notice. Illustrations and photos show the standard models, and may or may not include optional equipment, accessories, and all standard equipment with some differences in color and features. Before use, read and understand the Operator's Manual for proper operation.