

Performing to the highest quality standards.

# Cold Recycler and Soil Stabilizer WR model series

WR 200 | WR 200i | WR 240 | WR 240i | WR 250



# Outstanding features of the WR series of cold recyclers / soil stabilizers

02  
03

1 |

## WIDE RANGE OF APPLICATIONS

Finely tiered WR model series for a wide range of applications in soil stabilization and cold recycling.

1 |

2 |

## AUTOMATED FEATURES FOR EFFICIENT OPERATION

Numerous automated features ensure highly efficient operation.

2 |

3 |

## PRECISE METERING SYSTEMS FOR BINDER ADDITION

Reliable, high-precision metering systems for improved mixing quality.

4 |

3 |

9 |

9 |

## STEERING SYSTEM TAILORED TO FIELD REQUIREMENTS

Steering systems tailored to field requirements for maximum flexibility on the construction site.

8 |

8 |

## HIGH MILLING AND MIXING PERFORMANCE

Our expertise and experience of many years for maximum milling and mixing performance.

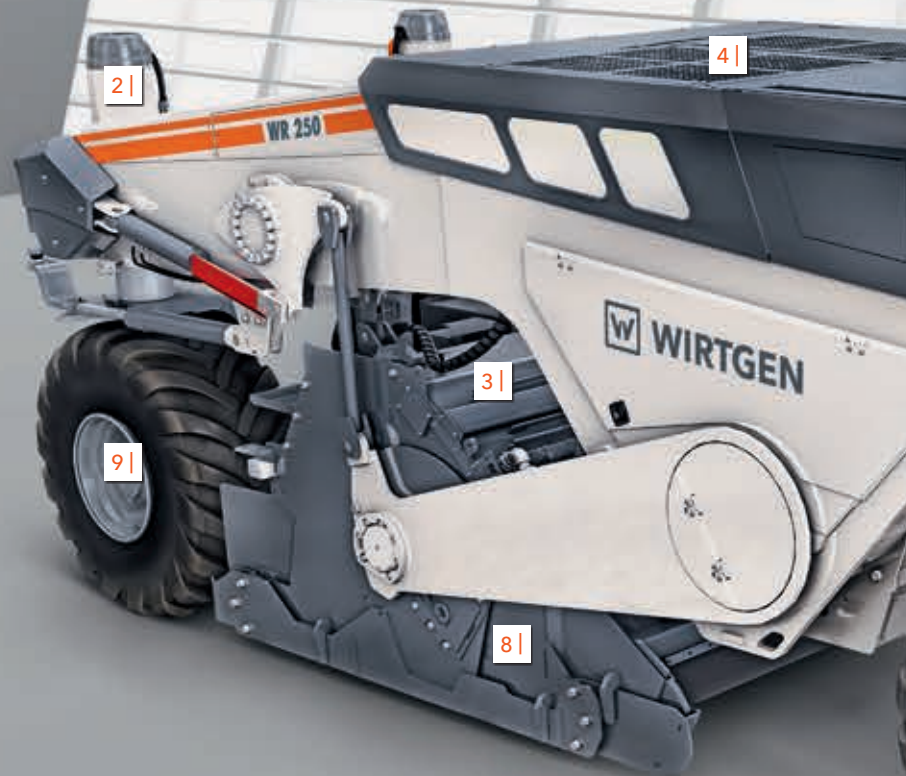

4 |

### EFFICIENT ENGINE AND DIAGNOSTIC SYSTEMS

High-powered engine and high-tech diagnostic systems for maximum operational availability.

5 |

### PERFECT VISIBILITY CONCEPT AND COMPREHENSIVE CAMERA SYSTEM

The operator is additionally supported by a perfect visibility concept and intelligent camera system.

6 |

### PERFECTION IN ERGONOMIC DESIGN AND HANDLING

Intuitive operating concept and outstanding ergonomic design for high machine productivity.

5 |

6 |

7 |

7 |

### OUTSTANDING ALL-TERRAIN MOBILITY

Unrivalled all-terrain mobility for maximum performance in particular in soil stabilization.







Added value

that pays dividends.

SOIL STABILIZER OR COLD RECYCLER? HIGH PERFORMANCE OR ECONOMIC EFFICIENCY? HIGH QUALITY OR HIGH PRODUCTIVITY? WHY DON'T YOU SIMPLY CHOOSE THEM ALL. CHOOSE A MACHINE FROM THE WIRTGEN WR MODEL SERIES. IT COMBINES ALL OF THESE FEATURES INTO A MACHINE CONCEPT OFFERING SUPERIOR QUALITY STANDARDS THROUGHOUT: FITTED WITH INNOVATIVE TECHNOLOGIES. FUTURE-PROOF. EFFECTIVE. THE WIRTGEN WR MODEL SERIES. THE PERFECT SOLUTION FOR EACH TYPE OF JOB.

# Three machine models - world class times three

06  
07

The compact  
WR 200 / WR 200i



The WR 200/WR 200i does not require a special permit for transport thanks to its compact design and low weight. The machine is suitable for a wide range of applications in both soil stabilization and cold recycling.

The multipurpose  
WR 240 / WR 240i



The WR 240/WR 240i is the all-rounder in the WIRTGEN fleet. It offers maximum flexibility for all applications in soil stabilization and cold recycling thanks to its large working width and working depth paired with high milling and mixing performance.

The top-performing  
WR 250



The WR 250 is a high-performance machine designed to cater to the particularly demanding applications. Its tremendous milling and mixing performance enables the WR 250 to tackle even the toughest jobs in soil stabilization and pulverize hard asphalt layers. With a host of advantages to recommend it, the WR 250 represents the yardstick when it comes to handling the greatest challenges in soil stabilization and cold recycling.

Working width:	2,000 mm
Working depth:	0 to 500 mm
Maximum engine output WR 200:	315 kW/428 PS
Maximum engine output WR 200i:	320 kW/435 PS
Operating weight, CE:	23,900 kg

Milling performance:	1.6 kW/cm
Ideal performance range in soil stabilization:	1,000 to 5,000 m <sup>2</sup> /day
Ideal performance range in cold recycling:	400 to 800 m <sup>2</sup> /h
Recycling depth in asphalt:	10 to 15 cm

Working width:	2,400 mm
Working depth:	0 to 510 mm
Maximum engine output WR 240:	455 kW/619 PS
Maximum engine output WR 240i:	447 kW/608 PS
Operating weight, CE:	29,400 kg

Milling performance:	1.9 kW/cm
Ideal performance range in soil stabilization:	4,000 to 8,000 m <sup>2</sup> /day
Ideal performance range in cold recycling:	500 to 1,000 m <sup>2</sup> /h
Recycling depth in asphalt:	15 to 20 cm

Working width:	2,400 mm
Working depth:	0 to 560 mm
Maximum engine output:	571 kW/777 PS
Operating weight, CE:	31,000 kg

Milling performance:	2.4 kW/cm
Ideal performance range in soil stabilization:	6,000 to 12,000 m <sup>2</sup> /day
Ideal performance range in cold recycling:	700 to 1,200 m <sup>2</sup> /h
Recycling depth in asphalt:	20 to 25 cm

# Wide range of applications

## FULL-FLEDGED SOIL STABILIZER

The finely tiered WIRTGEN WR model series offers the perfect solution for each type of job in soil stabilization and cold recycling. Soil stabilization scores top marks in comparison to soil exchange as it requires fewer truck transports, results in shorter construction times, saves resources and reduces CO<sub>2</sub> emissions. When operating as a soil stabilizer, the WR uses its powerful milling and mixing rotor to mix pre-spread binders, such as lime or cement, into the existing, insufficiently stable soil at working depths of up to 560 mm to convert it into a construction material of high quality in an in-situ process.

The resulting homogeneous soil-binder mixture offers high tensile strength, compressive strength and shear strength values as well as long-term water resistance, frost resistance and volume stability. Typical applications include the construction of paths, roads, motorways, foundations, parking lots, sports grounds, industrial parks or facilities, airports, embankments, backfills or landfills.

Its perfect ergonomic design and visibility concept, high performance and excellent mixing quality, maximum all-terrain mobility, automated features and numerous other highlights make the WR a pioneer on all soil stabilization sites in terms of delivering high performance at low cost.

The WR model series fully covers all performance classes in soil stabilization.

	WR 200/WR 200i	WR 240/WR 240i	WR 250
<b>Full performance range</b>	500 to 8,000 m <sup>2</sup> /day	1,000 to 10,000 m <sup>2</sup> /day	2,000 to 15,000 m <sup>2</sup> /day
<b>Ideal performance range</b>	1,000 to 5,000 m <sup>2</sup> /day	4,000 to 8,000 m <sup>2</sup> /day	6,000 to 12,000 m <sup>2</sup> /day

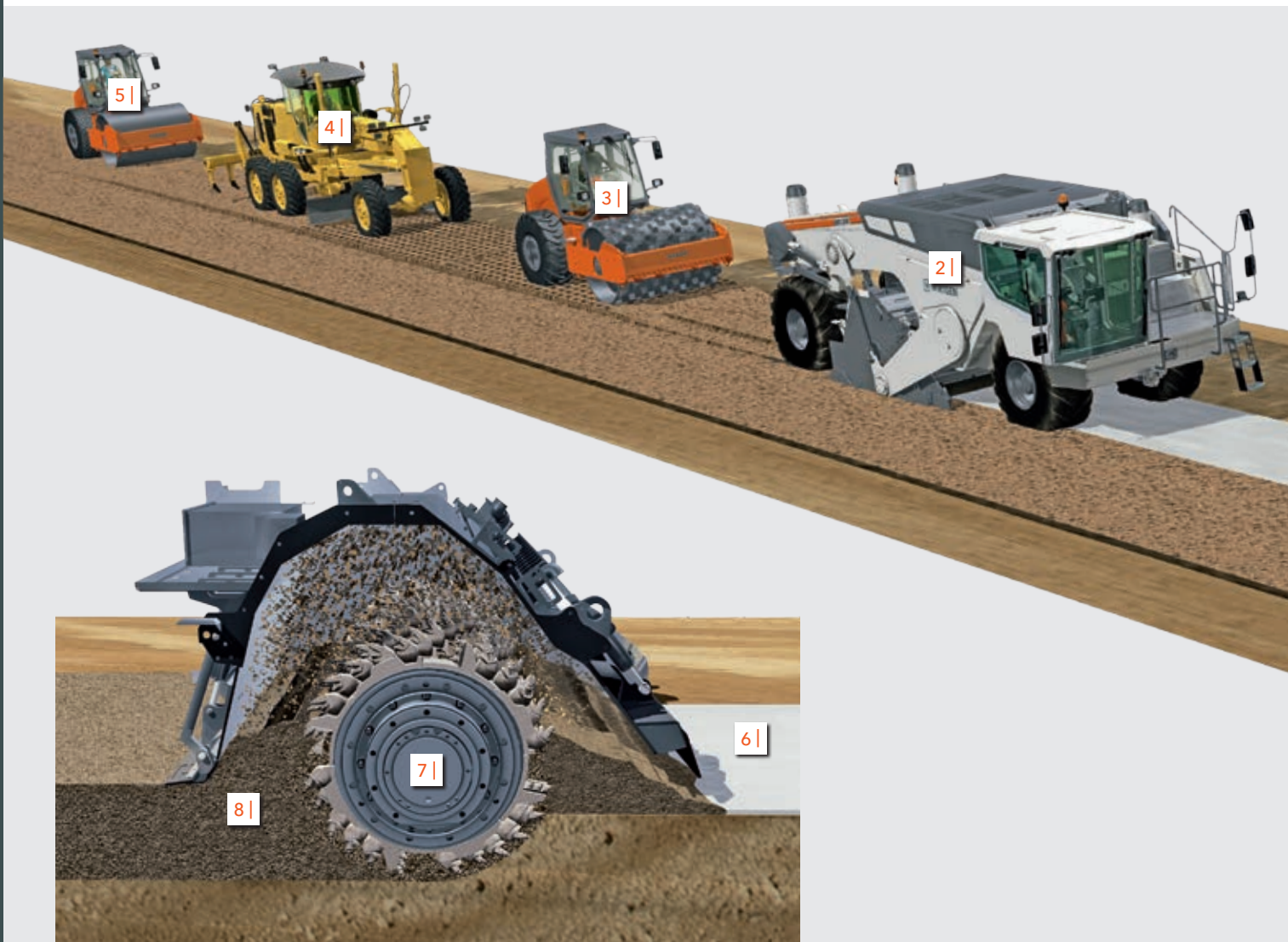





- 1 | Binder spreader
- 2 | WR soil stabilizer
- 3 | Single-drum compactor
- 4 | Grader

- 5 | Single-drum compactor
- 6 | Pre-spread binder
- 7 | Milling and mixing rotor
- 8 | Processed, homogeneous soil-binder mixture



# Wide range of applications

## HOMOGENIZATION

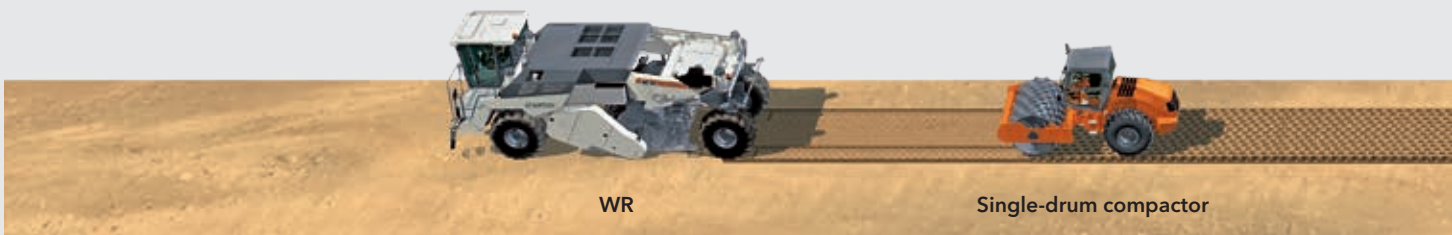

## SOIL STABILIZATION WITH ADDED LIME



## SOIL STABILIZATION WITH ADDED CEMENT



For homogenization, the WR uses its powerful milling and mixing rotor to granulate and scarify the existing soil without added binders. The homogenized soil mixture is graded by a motor grader and then compacted by different HAMM rollers.



For soil stabilization, binder is pre-spread in a first step by the all-wheel driven Streumaster SW 19 SC "Rhino". Following behind the binder spreader, the WR uses its powerful milling and mixing rotor to mix the existing soil and pre-spread binder. The resulting homogeneous soil mixture is graded by a motor grader and then compacted by different HAMM rollers.



For the production of a new hydraulically bound base layer, cement is pre-spread in a first step by a Streumaster towed spreader, which is followed by a water tanker truck. The WR then uses its powerful milling and mixing rotor to mix the existing material and pre-spread cement. Water is simultaneously injected into the mixing chamber via an injection bar. The resulting homogeneous base course material is graded by a motor grader and then compacted by different HAMM rollers.



# Wide range of applications

## HIGH-PERFORMANCE COLD RECYCLER

Steadily increasing volumes of car and truck traffic cause structural damage to the individual layers of asphalt roads over time, thus reducing their bearing capacity. When operating as a recycler, the WR corrects these deficiencies quickly and economically while being efficient on resources at the same time. It is equipped with a powerful milling and mixing rotor and state-of-the-art injection systems. The cold recycler mills and granulates the existing asphalt pavement, injects binders and water in precisely metered quantities and mixes all three in a single operation. The new base layers produced in this in-situ process

are distinctive for their exceptionally high bearing capacity.

The range of additives or binders suitable for cold recycling includes cement, water, bitumen emulsion and foamed bitumen. Highly precise metering, consistently high mixing quality, clearly structured, easy operation and precise levelling guarantee perfect work results.

The different machines of the WR model series are the ideal choice for all types of operations ranging from the recycling of thin asphalt layers on minor roads with low traffic volumes all the way to recycling up to 250-mm thick asphalt layers on heavily trafficked motorways exposed to extremely high loads.

The WR model series covers the full range of applications in cold recycling.

	WR 200/WR 200i	WR 240/WR 240i	WR 250
<b>Ideal performance range</b>	up to 800 m <sup>2</sup> /h	up to 1,000 m <sup>2</sup> /h	up to 1,200 m <sup>2</sup> /h
<b>Recycling depth in asphalt</b>	10 to 15 cm	15 to 20 cm	20 to 25 cm





- |   |  |
|---|--|
| 1   Bitumen tanker truck  | 6   Tandem roller                                |
| 2   WM 1000 slurry mixer (in combination with WR 240/WR 240i/WR 250 only) | 7   Milling and mixing rotor                     |
| 3   WR 240/WR 240i/WR 250 cold recycler                                   | 8   Injected foamed bitumen                      |
| 4   Single-drum compactor   | 9   Injected water-cement slurry                 |
| 5   Grader  | 10   Recycled, homogeneous construction material |



# Wide range of applications

## RECYCLING WITH PRE-SPREAD CEMENT



Binder spreader

Water tanker truck

WR

## RECYCLING WITH PRE-SPREAD CEMENT AND BITUMEN EMULSION



Binder spreader

Water tanker truck

Emulsion tanker truck

## RECYCLING WITH CEMENT SLURRY AND FOAMED BITUMEN



Bitumen tanker truck

WM 1000 slurry mixer

WR 240/WR 240i, WR 250

For the production of a hydraulically bound base layer, a layer of cement is pre-spread in a first step by a Streumaster binder spreader, which is followed by a water tanker truck. The WR uses its powerful milling and mixing rotor to granulate the damaged pavement layers, simultaneously mixing in the pre-spread cement and injected water. The resulting homogeneous construction material is finish-graded by a motor grader and then compacted by different HAMM rollers.



Small quantities of cement are pre-spread in a first step by a Streumaster binder spreader, which is followed by water and emulsion tanker trucks. The WR uses its powerful milling and mixing rotor to granulate the damaged pavement layers, simultaneously mixing in the pre-spread cement and injecting water and bitumen emulsion into the mixing chamber via two separate, microprocessor-controlled injection bars. The resulting homogeneous construction material is finish-graded by a motor grader and then compacted by different HAMM rollers.

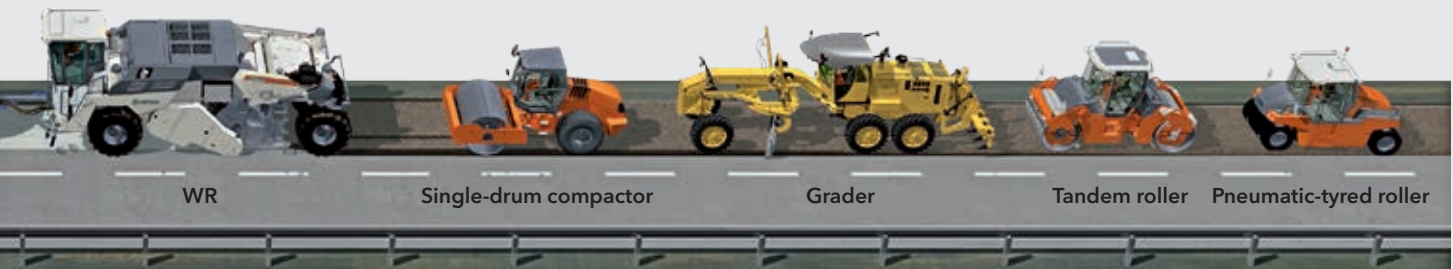

A bitumen tanker truck travels ahead, followed by a WIRTGEN WM 1000 slurry mixer. The bitumen tanker truck and slurry mixer supply the WR 240/WR 240i, WR 250 with the binders required for recycling the pavement in need of repair. The recycler uses its powerful milling and mixing rotor to granulate the damaged pavement layers, simultaneously injecting water-cement slurry and foamed bitumen into the mixing chamber via two microprocessor-controlled injection bars. The resulting homogeneous construction material is finish-graded by a motor grader and then compacted by different HAMM rollers.

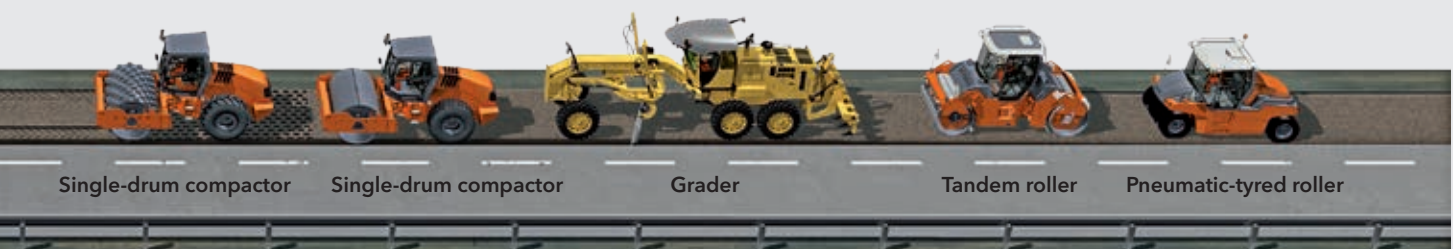







**Designed with  
human-machine  
interaction in mind.**

ALL IS SET TO GO, WAITING FOR YOUR COMMAND. INNOVATIVE COMPUTER-ASSISTED SYSTEMS ARE THERE TO SUPPORT YOU. RELIEVING YOU OF A SIGNIFICANT PART OF YOUR WORKLOAD. ECONOMIC. PRODUCTIVE. ADD TO THIS: PERFECTION IN ERGONOMIC DESIGN, VISIBILITY AND COMFORT IN THE INNOVATIVE, SPACIOUS OPERATOR'S CABIN. GIVING YOU FULL CONTROL: PERFECTLY DESIGNED INTERACTION BETWEEN MAN AND MACHINE. RELAXED WORKING, TREMENDOUS OUTPUT.



## Perfection in ergonomic design and handling

### SPACE AND OPERATOR COMFORT - TWO PREREQUISITES FOR SUCCESS

The workplace of the machine operator has been designed with precisely this concept in mind. The soundproof, spacious cabin of the WR offers ample room to move, a comfortable interior and pleasant indoor temperatures.

Its numerous equipment features include a comfortable driver's seat, powerful climate control and heating system, radio with CD player, compressed-air connection and air gun for cabin cleaning, backlit controls and ample storage space. These features not only increase operator comfort and performance but also improve the machine's productivity on a daily basis.



1 |



2 |

1 | The multifunctional joystick on the right arm console fits perfectly into the palm of the operator's hand.

2 | The colour screen mounted on the steering column is positioned in the operator's immediate field of view.

## TAKING ERGONOMICS TO A WHOLE NEW LEVEL

The anatomically shaped driver's seat with spring and air cushioning is the WR's showpiece in terms of ergonomic design. It can be fully adjusted to the operator's personal preferences, guaranteeing a comfortable seating position for many hours. In addition, ergonomically designed controls are integrated in both arm consoles. Arranged within easy

reach, they allow intuitive operation. All important machine features have been grouped together intelligently in the multifunctional joystick of the right-hand arm console and can therefore be performed with effortless ease. The entire driver's seat including arm consoles and steering column can be swivelled through 90 degrees to either side, giving the operator full visibility towards the rear of the machine while maintaining a relaxed body posture.

*The individually adjustable comfort seat enables the operator to find the perfect position.*



1 | The machine offers ready access to the spacious operator's cabin.

2 | Transport is permitted on all standard flatbed trucks - the WR 200 does not even require a special transport permit.



## Perfection in ergonomic design and handling

### THE WR MAKES WORK EASY - DAY AFTER DAY

Construction projects are nowadays carried out under tremendous pressure of time with no regard for adverse weather, darkness or night. This is where the intelligent lighting concept comes into play. The lighting system of the WR comprises six working lights at the front of the cabin, optionally in LED design, two spotlights each on the left and right side, two cornering lights at the rear and two spotlights allowing flexible mounting by means of magnetic bases.

*The comprehensive lighting system fully illuminates all important points of the machine and its surroundings.*

Operation can thus continue at full swing even after the sun has set. "Welcome" and "Go home" lights feature: when walking towards or away from the WR, the machine's surroundings can be illuminated by means of LED lights. Safety first: side railings are folded up in a few simple steps when working on the engine or cooler. The cabin complies with ROPS / FOPS standards, offering maximum protection for the machine operator.





# Automated features for efficient operation

*The WR raises the rotor out of the cut while reversing.*

## **BOOSTING PERFORMANCE AT THE MERE PUSH OF A BUTTON**

The WR has been provided with an intelligent automated feature which controls lowering and raising of the milling and mixing rotor. The operator initiates the automated process by means of the multifunctional joystick; the WR completes it all on its own: in a first step, the machine is lowered rapidly, and the front and rear rotor plates move into previously specified positions. Once the lifting columns are in working position, the milling and mixing rotor is lowered into the ground until the previously set working depth has been reached. Moving the joystick forward then enables forward motion of the machine. The excavation developing at the end of each cut is closed by initiating - via joystick - the automated feature raising the rotor out of the cut.

While the WR drives a few metres, the cut is fully closed by one of the rotor plates. At the same time, the rotor is slowly raised out of the cut, and the lifting columns move the machine into transport position.

*The milling and mixing rotor moves into the previously specified position.*





*Large glass windows and numerous mirrors offer excellent visibility.*

# Perfect visibility concept and comprehensive camera system

## **ENHANCED VISIBILITY ENHANCES PRODUCTIVITY**

Good visibility is of vital importance for safe operation and fast-paced processes. The WR offers a visibility concept that is unique in the industry: large glass windows on the left, front and right side of the cabin are complemented by a set of mirrors tailored to field requirements to provide the operator with a full view of the entire construction site. The spacious cabin can be moved to project over the edge of the machine on the right, and the driver's seat swivelled through 90 degrees to offer an

unobstructed view of the working edge. This array of features makes child's play of operating flush to kerb without the need for extensive reworking.

The excellent view of the working edge on the right side of the machine ensures highly precise recycling along pavement kerbs on the one hand while enabling highly precise overlaps on the other.



1-2 | The cabin can be moved far to the right hydraulically, enabling the operator to look past a recycling train travelling ahead.

3 | Turning his seat after moving the cabin to the right gives the operator a full view of the right-hand working edge.

4 | The right-hand wheels travel inside the working width to allow flush-to-kerb operation.

# Perfect visibility concept and comprehensive camera system

## SECOND-TO-NONE CAMERA SYSTEM

Camera systems are developing into increasingly important support tools when it comes to monitoring the operation and process sequences of machines and applications in which good visibility is a must. A reversing camera is included in the basic on-board equipment package of the WR model series.

The intelligent reverse assist system supports the machine operator during reverse travel by fading in driving assistance lines.

At the customer's request, a system comprising as many as four high-resolution colour cameras can be installed at the rear of the machine, on the left side of the machine and underneath the machine at the front and rear rotor plates. When operating several cameras, an additional screen is installed to display the camera images.

In the final analysis, complete visibility into important operating processes and areas, such as driving up to obstacles or assessing work results, achieves a significant increase in quality, performance and economic efficiency.

*Four cameras offer perfect visibility and maximum operator comfort.*

## OVERVIEW OF CAMERAS:



1 | Camera on the left machine side



2 | Camera at the rear of machine

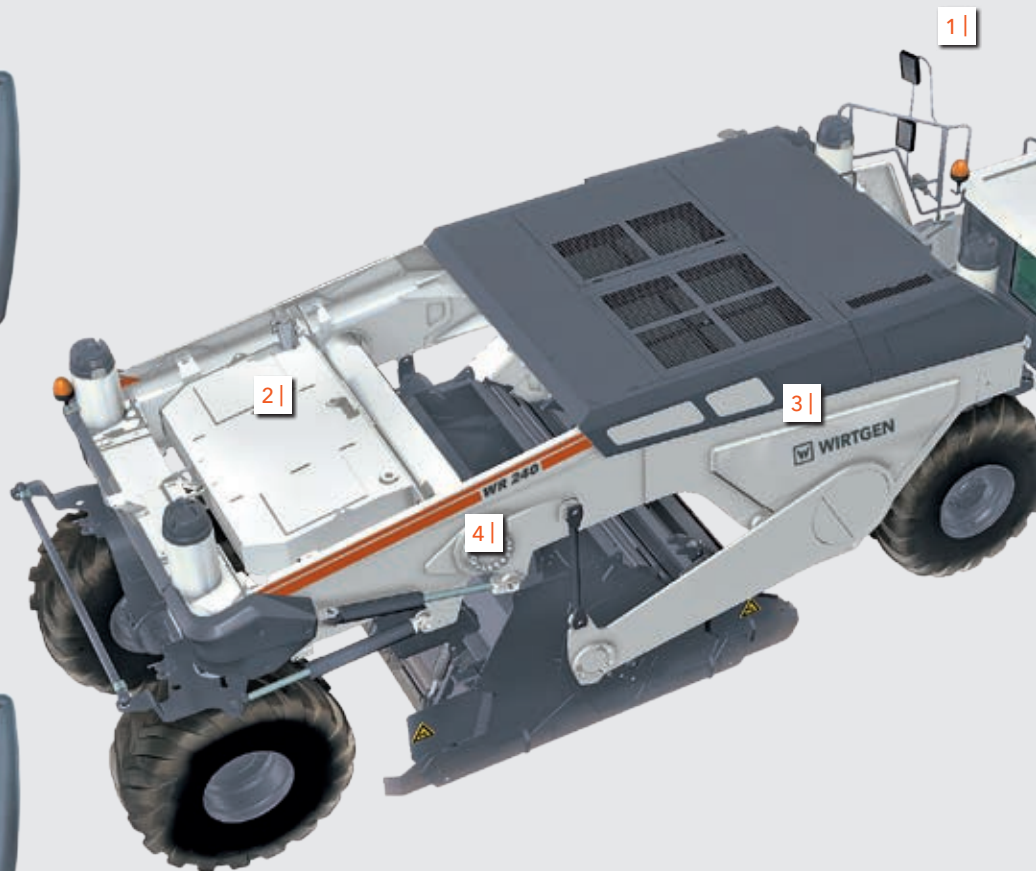



1 |



1 | The images are displayed on the control screen - including automatic reverse assist.

2 | The camera installed at the rear provides images of what is going on behind the machine.

3 | Switching between cameras is effected manually via the joystick.



4 | Camera at the front rotor plate



3 | Camera at the rear rotor plate

2 |



3 |





**Compelling features designed for  
an entirely new performance class.**



EVERYDAY CHALLENGES ON THE CONSTRUCTION SITE: EXTREMELY UNEVEN GROUND. MANOEUVRING IN RESTRICTED SPACE CONDITIONS. STABILIZING OR RECYCLING ON DIFFICULT GROUND. ROUTINE FOR THE WR. INNOVATIVE WIRTTGEN TECHNOLOGIES PUT YOUR COMMANDS INTO ACTION WITH PINPOINT PRECISION. ADD TO THIS: HIGH ENGINE POWER AND AMPLE POWER RESERVES. THE WR: BENCHMARK IN DRIVING STABILITY, MANOEUVRABILITY AND TRACTION - TAKING PERFORMANCE TO AN ENTIRELY NEW DIMENSION.



*The machine's all-wheel drive enables it to operate even on deep, excessively wet ground.*

## Outstanding all-terrain mobility

### EASY JOB ON HEAVY GROUND

Traction is the magic word for efficient soil stabilization on deep, muddy ground, and of that the WR has enough and to spare. Extra large, deep-tread tyres are effective in transmitting the engine's high drive power into the ground. The powerful all-wheel drive ensures constant maximum traction of each of the four hydrostatically driven wheels. Intelligent distribution of the machine's weight adds to ensuring uniform traction. An automatic power controller governs the machine's advance speed in accordance with the engine load, thus dispensing with the need to engage or disengage the differential lock.

Automatic height adjustment via the machine's fourfold full-floating axle is yet another feature that plays its trumps where high ground clearance is required when operating on deep, muddy ground. The machine's advance speed is continuously adjustable from zero to maximum speed both during operation and in transport mode.

In short: the WR is the ideal candidate for mixing in binders on difficult ground.

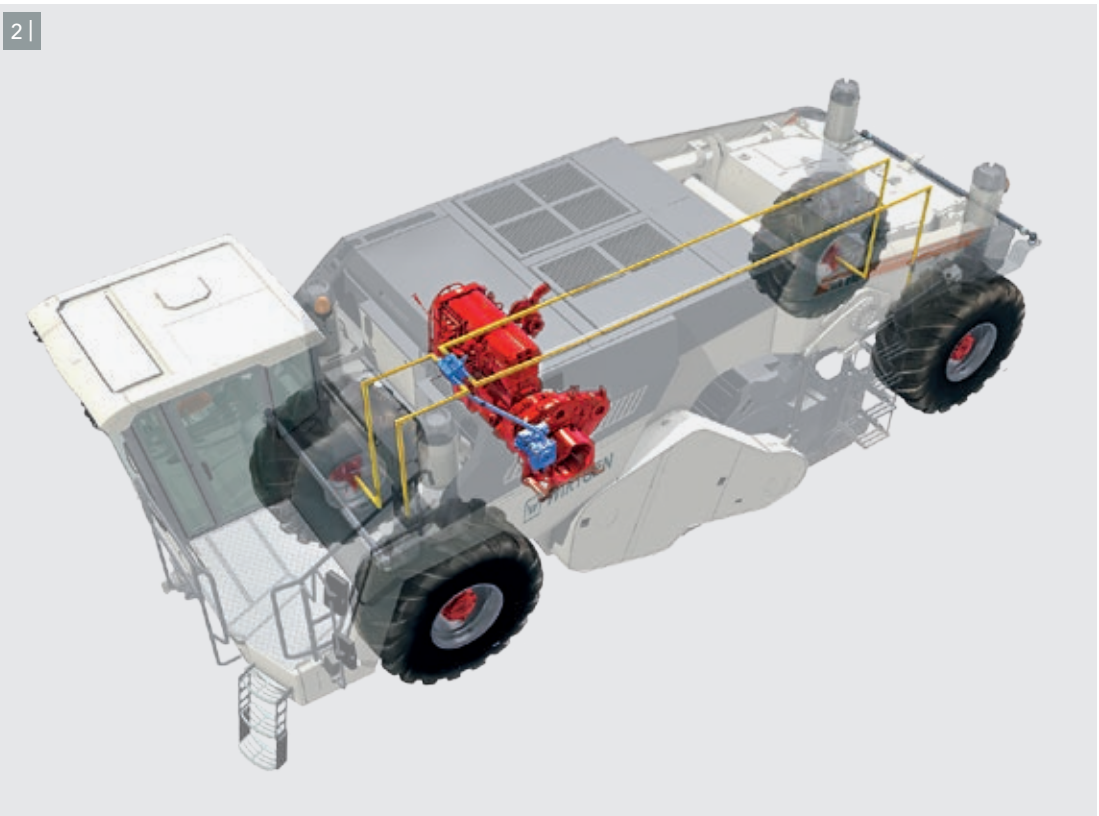

1 | The engageable hydraulic flow divider guarantees consistently high traction regardless of ground conditions.

2 | The machine's all-wheel drive distributes the drive power evenly to all four wheels.



*Levelling out ground irregularities is an easy exercise for the WR.*

## Outstanding all-terrain mobility

### STABLE DRIVING PERFORMANCE AND AMPLE GROUND CLEARANCE

The WR moves effortlessly even on extremely uneven ground while retaining its horizontal alignment all the time. The machine's automatic fourfold full-floating axle and electronic cross slope sensor are important features when it comes to ensuring machine stability and balance. The cross slope sensor enables the WR to operate parallel to the surface or at the specified cross slope. The tried-and-tested, fourfold full-floating lifting column design can be relied on to level out any major ground irregularities quickly and in a dynamic process. It enables the milling and mixing

rotor to always maintain the specified working depth both on the left and right side, thus ensuring precise work results. The wheels are height-adjustable in pairs - left, right, front or rear - for full adjustment to site conditions. When driving crosswise on sloping terrain, the operator can adjust the machine to a more convenient horizontal position by means of the "roll" feature. And the operator benefits, too - high driving convenience promotes relaxed working.

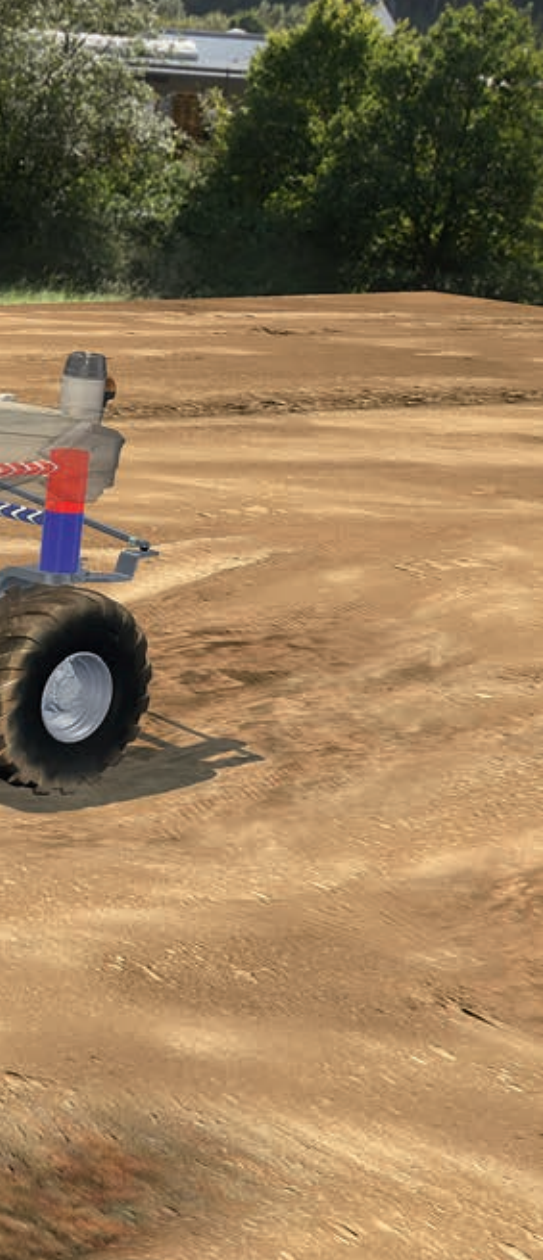

1 | The cross slope sensor is used to set and maintain the specified cross slope.

2 | Longitudinal gradient and cross slope are adjusted conveniently via the left-hand joystick.

3-4 | "Roll" feature: the machine levels out horizontally at the mere flick of a switch.



**Straight-ahead mode:**  
the front wheels are steered via the steering wheel.

The rear wheels remain in straight-ahead position automatically but can be steered separately via the joystick.



Working  
direction



Working  
direction



**Crab steering mode:**  
all four wheels are steered at parallel angles via the steering wheel.

Working  
direction

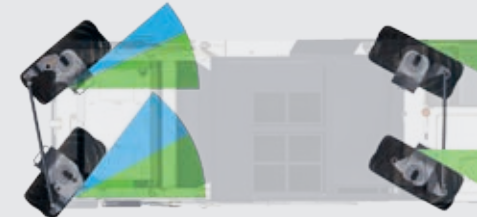

Working  
direction



*Different steering modes for superior ease of operation.*

## Steering system tailored to field requirements

### QUICK MANOEUVRING IN RESTRICTED SPACE CONDITIONS

An electrohydraulic “steer-by-wire” steering system provides the WR with everything it takes for easy and smooth steering behaviour. The machine operator can choose among three different steering modes: straight-ahead, crab or cornering mode. Each of the three steering modes is the fastest way to reach the intended position in its specified field of application. In cornering mode, the WR is capable of performing a minimum turning radius of 4,500 mm. The innovative oversteering feature enables the rear wheels to be turned even further, allowing the WR to perform an excep-

tionally small turning radius of no more than 3,150 mm. This undercuts even the minimum turning radius of standard passenger cars.

The currently selected steering mode is clearly displayed at all times and can be conveniently changed via the multifunctional joystick. The highly precise steering system and free choice of steering mode relieve the operator, enabling him to focus on productivity and on ensuring that his work meets the highest quality standards.





**Cornering mode:**  
the front and rear wheels are steered synchronously via the steering wheel to permit small turning radii.



**Cornering mode with oversteering feature:**  
once a specified steering angle has been reached, the rear wheels can be turned even further via the steering wheel. Oversteering enables even smaller turning radii to be achieved.

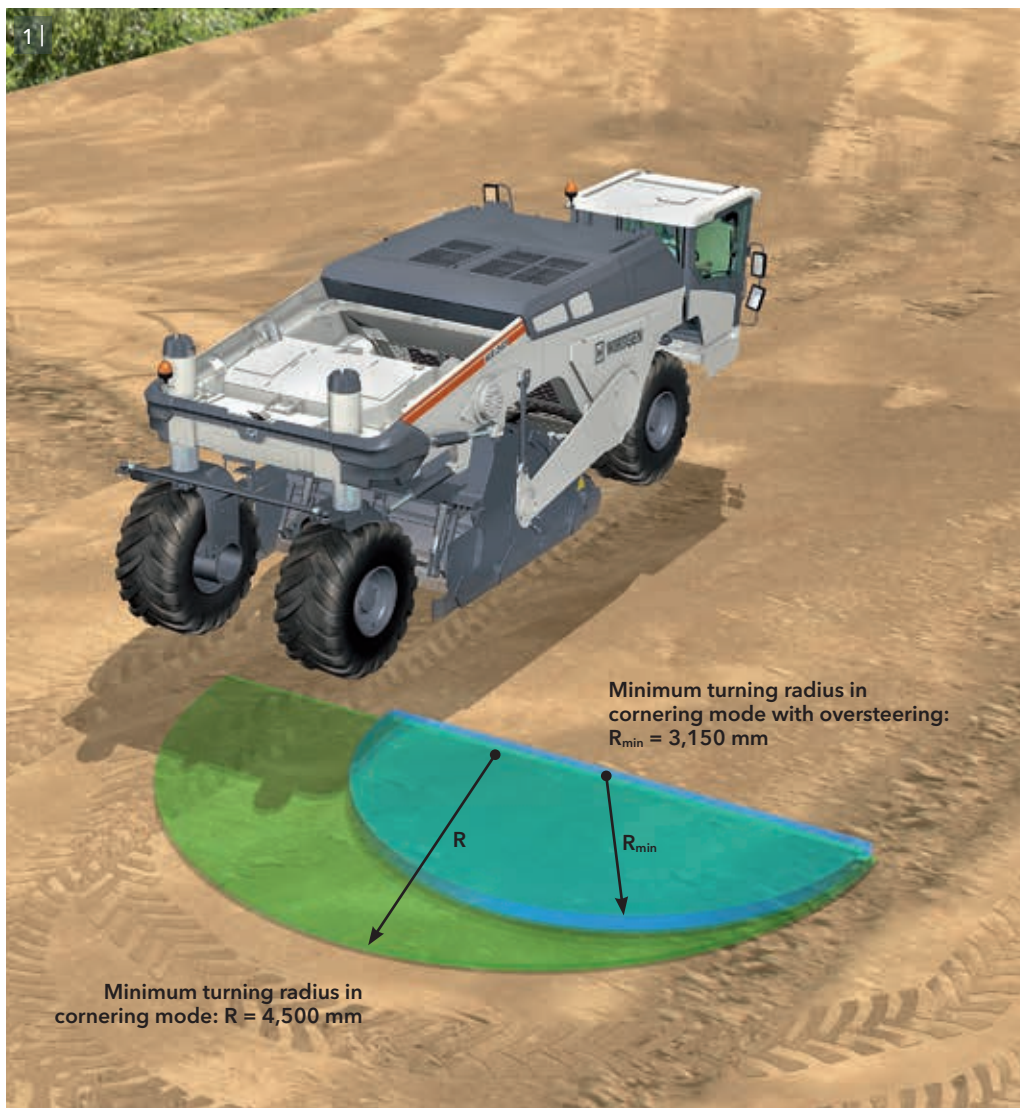

Minimum turning radius in cornering mode with oversteering:  
 $R_{min} = 3,150 \text{ mm}$

Minimum turning radius in cornering mode:  $R = 4,500 \text{ mm}$



1 | In cornering mode, the machine operator can oversteer the rear axle to achieve minimum turning radii.

2 | The exceedingly small turning radius enables quick turning manoeuvres even in extremely restricted space conditions.

# Efficient engine and diagnostic systems

## SUPERIOR ENGINE TECHNOLOGY

The state-of-the-art, high-torque diesel engine installed in the WR model series is the ideal candidate for strength-sapping soil stabilization and cold recycling operations. But it also uses its "brains" as the intelligent, fully electronic engine management system optimizes engine performance: the torque is maintained at a constantly high level even in case of extreme engine lugging. If required, ample torque reserves enable even higher engine outputs to be achieved. Automatic adjustment of the engine speed reduces fuel consumption.

Needless to say that the engine technology of the WR model series complies with the current standards of exhaust gas after-treatment:

WR 200 = EU Stage 3a/US Tier 3  
WR 200i = EU Stage 4/US Tier 4f  
WR 240 = EU Stage 3a/US Tier 3  
WR 240i = EU Stage 4/US Tier 4f  
WR 250 = US Tier 2





1 |

1 | The soundproof engine cowling opens at a mere flick of the wrist.

2 | All engine models installed in the different WR models impress with ideal characteristics: increased engine loading reduces engine speed and increases torque while the engine output remains nearly constant.



2 |

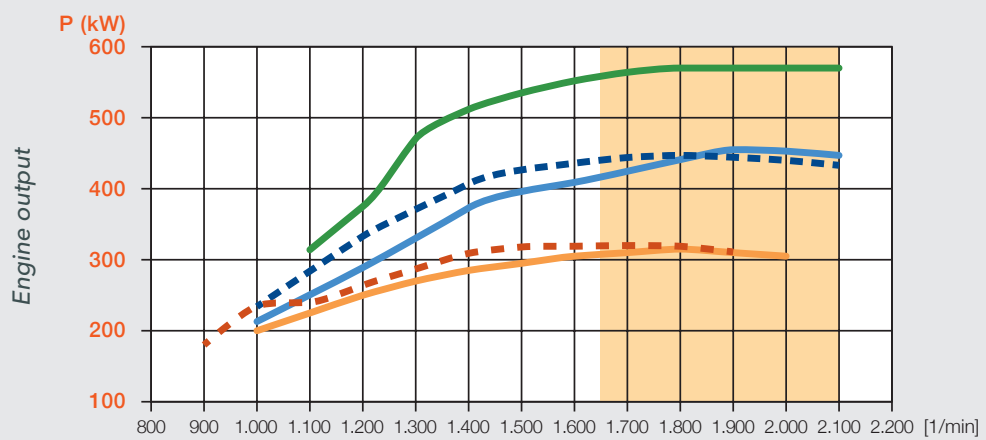
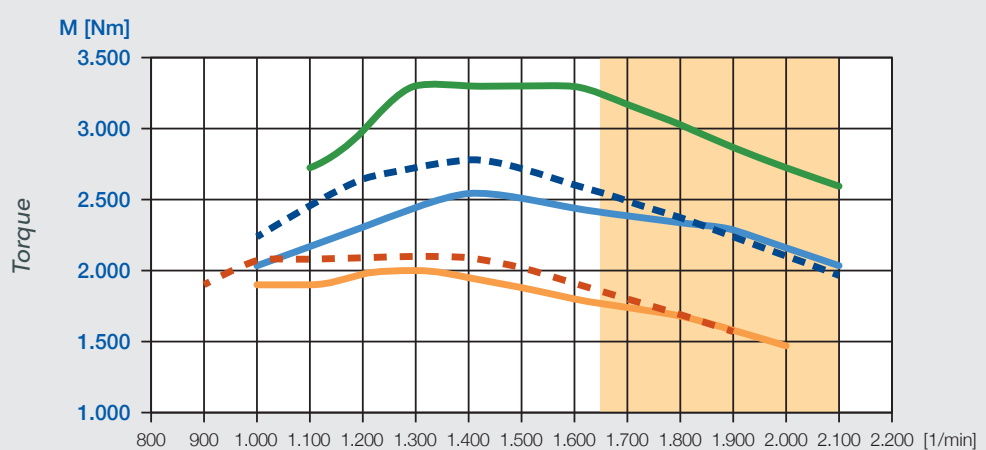

— WR 200    — WR 240    — WR 250     Engine speed in operation = 1,650 to 2,100 min<sup>-1</sup>  
- - - WR 200i    - - - WR 240i



1 |

1 | *High-tech diagnostic systems increase productivity.*

# Efficient engine and diagnostic systems

## QUICK ON-BOARD DIAGNOSTICS

State-of-the-art measuring technology is by far superior to conventional, manual measuring methods. We have therefore equipped the WR with high-tech diagnostic systems which enable maintenance diagnostics, parameter settings or troubleshooting to be performed quite effortlessly via the control panel in the operator's cabin. The machine's automatic diagnostic system autonomously monitors valves, sensors and control components. Numerous clearly visualized pages provide quick

and accurate information on the machine's current operating parameters. In addition, maintenance requirements are minimized by extended servicing intervals and an intelligent maintenance concept. The few points of maintenance are arranged in a clear pattern and offer easy access from the ground or via access ladders.

In short: maximum operational availability of the WR is ensured.



2 | When opened, the engine cowling offers ready access to the engine compartment, hydraulic system, air filter and pumps.

3 | The oil level can be checked quickly and easily from the ground.



4 | Diagnostics and parameter settings are performed via the control screen.





**High-tech features**

**for premium quality:**

**it's the mix that counts.**

PERFECTLY ENGINEERED MILLING TECHNOLOGY - WIRTGEN'S CORE EXPERTISE. USING PERFECTLY MATCHED HIGH-TECH COMPONENTS. MANUFACTURED FROM HIGH-QUALITY MATERIALS, OPTIMIZED IN BOTH FUNCTIONALITY AND DESIGN. INCLUDING STATE-OF-THE-ART, HIGHLY PRECISE METERING SYSTEMS FOR DIFFERENT TYPES OF BINDERS. FOR HIGH MILLING AND MIXING PERFORMANCE, PERFECT MIXING QUALITY AND HIGH AREA PERFORMANCE. IN OTHER WORDS: SUCCESS GUARANTEED.



11

1 | WIRTGEN milling and mixing rotors guarantee perfect mix quality.

# High milling and mixing performance

## HEART AND SOUL - THE PERFECTLY ENGINEERED MILLING AND MIXING ROTOR

Milling technology is our core expertise, and that is why the milling and mixing rotor installed in the WR appears to be cast from a single mould. Engine output and milling performance of the different machine models have been perfectly matched, the respective combinations of working width and working depth enabling efficient operation. The massive rotor design promotes smooth rotation without any jolts or shocks, thus reducing stress and strain on the drive elements. Toolholders on high bases have been arranged across the entire width of the milling and

mixing rotor in a perfect pattern to guarantee homogeneous mixing of the construction materials regardless of the working depth. The hydraulic rotor turning device moves the rotor into the ideal position effortlessly to assist the operator with tool replacement. In addition, the hard-wearing quick-change toolholder system ensures optimum tool rotation, easy tool replacement and effective, continuous operation for extended periods of time.





2	WR 200/ WR 200i	WR 240/ WR 240i	WR 250
Working width	2,000 mm	2,400 mm	2,400 mm
Working depth	0 to 500 mm	0 to 510 mm	0 to 560 mm

3	WR 200/ WR 200i	WR 240/ WR 240i	WR 250
Maximum engine output	315 kW 320 kW	455 kW 447 kW	571 kW
Milling performance	1.6 kW/cm	1.9 kW/cm	2.4 kW/cm



2 | Comparing the working width and working depth of the different machine models.

3 | Comparing the engine output and milling performance of the different machine models.



4 | Homogeneous quality of the recycled mix even in tough operating conditions.

5 | Tool replacement made easy using the hydraulic cutting tool extractor.

# High milling and mixing performance

1 | *The intelligent drive design ensures fuel economy and ease of maintenance.*

2 | *Different engine speeds can be adjusted from the operator's platform.*



## EFFECTIVE MILLING ROTOR DRIVE

The WR features a direct mechanical rotor drive which translates high engine power into an equally high milling and mixing output. Large wrap angles on the belt pulleys enable the heavy-duty power belt to transmit the engine power to the rotor gearbox with only minimum performance losses, thus ensuring high efficiency. Positive side effects of the intelligent drive concept are fuel economy and ease of maintenance.

*Direct mechanical drive via power belt with automatic belt tensioner.*

In addition, nine (WR 200/WR 200i, WR 240/WR 240i) and twelve (WR 250) different rotor speeds, respectively can be adjusted via the right-hand arm console in the operator's cabin and the two-stage rotor gearbox on the one hand, and by repositioning the belt pulleys on the other. When adjusted to the correct rotor speed, the WR achieves the specified mixing results at the highest possible advance speed and lowest possible fuel consumption rates.

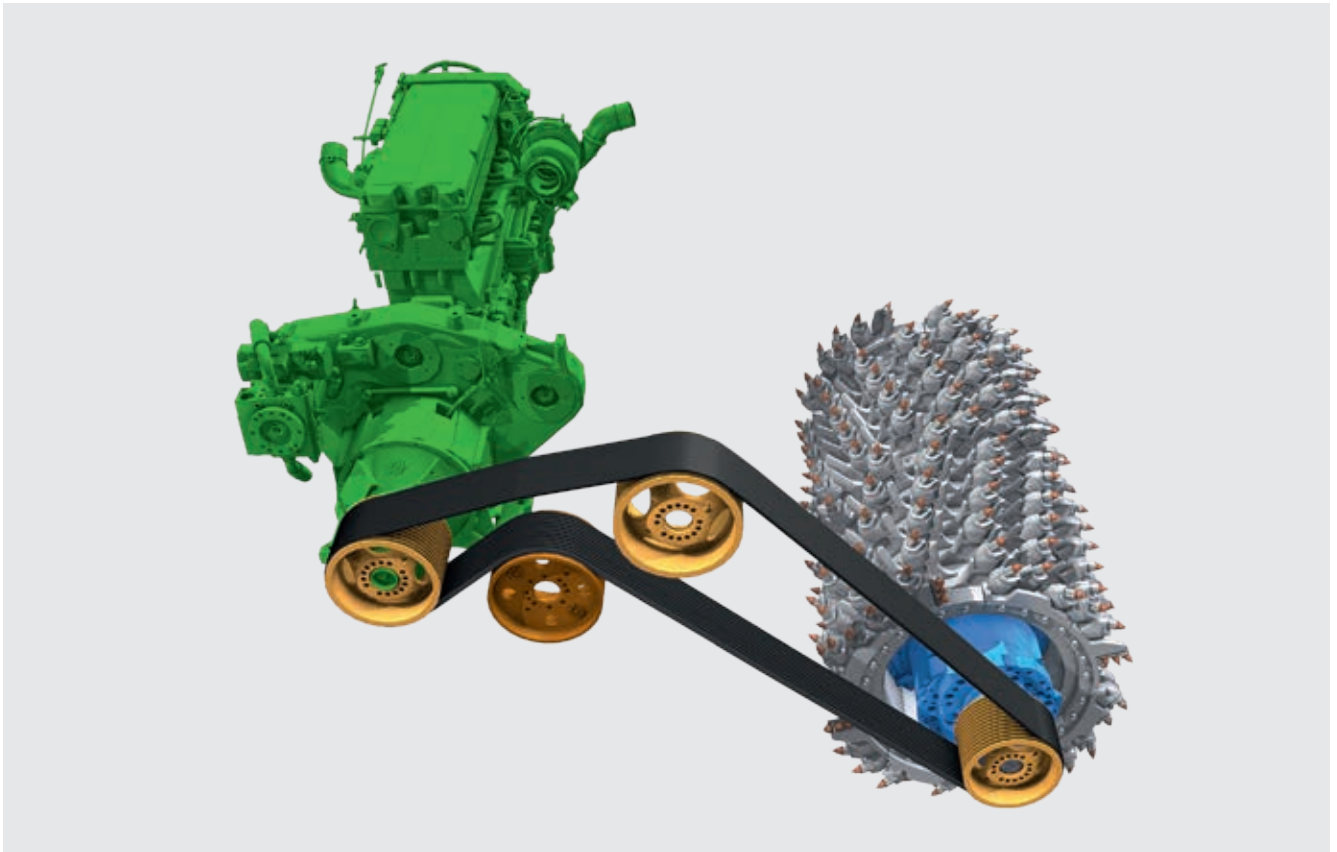

## ROTOR LA 20 FOR WR 200/WR 200i, WR 240/WR 240i

Regardless of whether the agenda specifies soil stabilization or cold recycling operations – for each model of the WR series, only one milling and mixing rotor is needed to complete the job. The rotor of the WR 200/WR 200i, WR 240/WR 240i is fitted with cutting tools arranged at a tool spacing of 20 mm. The tooling has been perfectly tailored to the performance of these machine models and represents the ideal solution for all applications in soil stabilization and cold recycling. Toolholders with shank diameters of 22 mm or 25 mm can be used in accordance with application requirements.

## ROTOR LA 30X2 FOR WR 250

The rotor installed in the WR 250 has a tool spacing of 30x2 mm – two cutting tools per turn are positioned at a tool spacing of 30 mm each. Featuring a large number of cutting tools, the rotor has been perfectly matched to the machine's high performance and high advance speed.

Combining high engine power with an exceptionally robust milling and mixing rotor ensures premium mix quality even at high machine advance rates. Toolholders with shank diameters of 22 mm or 25 mm can be used in accordance with application requirements.

*Equipped with the LA 30 x 2 rotor, the WR 250 achieves the exceptionally high production rates specified for this operation.*



## MILLING AND MIXING ROTOR FOR THE WR 250

Cutting tool arrangement precisely tailored to the performance of the WR 250

Cutting tool arrangement at a tool spacing LA = 30x2 mm

Rotor especially suitable for tough cold recycling applications, such as pulverizing hard asphalt layers

Hard-wearing quick-change toolholder system

High, heavy-duty forged holder bases

Large number of cutting tools for high mix quality at high advance rates

Interchangeable edge ring segments open at the sides

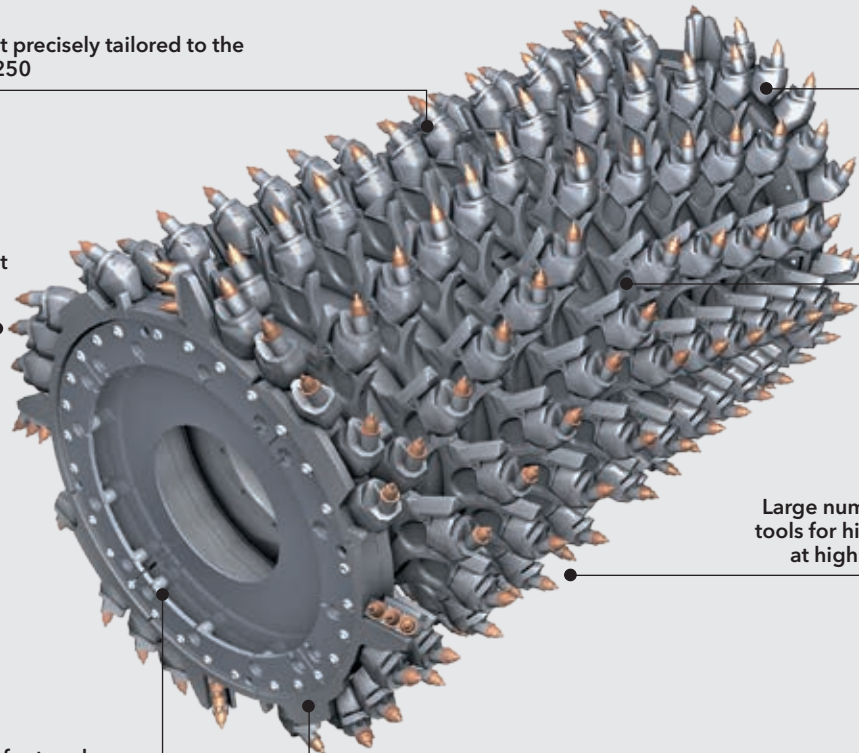



*The hydraulically adjustable crusher bar at the front rotor plate pulverizes even large asphalt slabs.*

## High milling and mixing performance

### **PREMIUM MIXING QUALITY REGARDLESS OF THE WORKING DEPTH**

The rotor housing and rotor plates have been designed to perfectly match the powerful milling and mixing rotor. The mixing chamber volume is adjusted to the current working depth and material quantity automatically by raising or lowering the rotor. The variable mixing chamber increases with the working depth, thus ensuring maximum performance and good mixing results even when operating at the maximum depth.

These features enable the machine to produce perfectly homogeneous mixes from the milled material and binders added. In addition, optimized transport of the mix in the rotor housing results in a tremendous increase in throughput and productivity. The rotor plates at the front and rear provide effective closure of the mixing chamber, serve as material guides and are used to level off the stabilized or recycled layer.

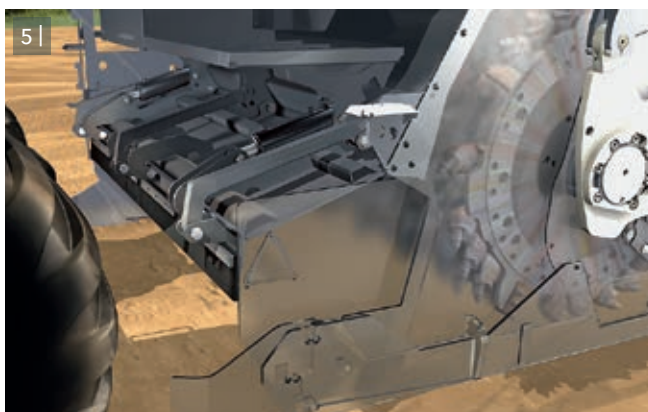
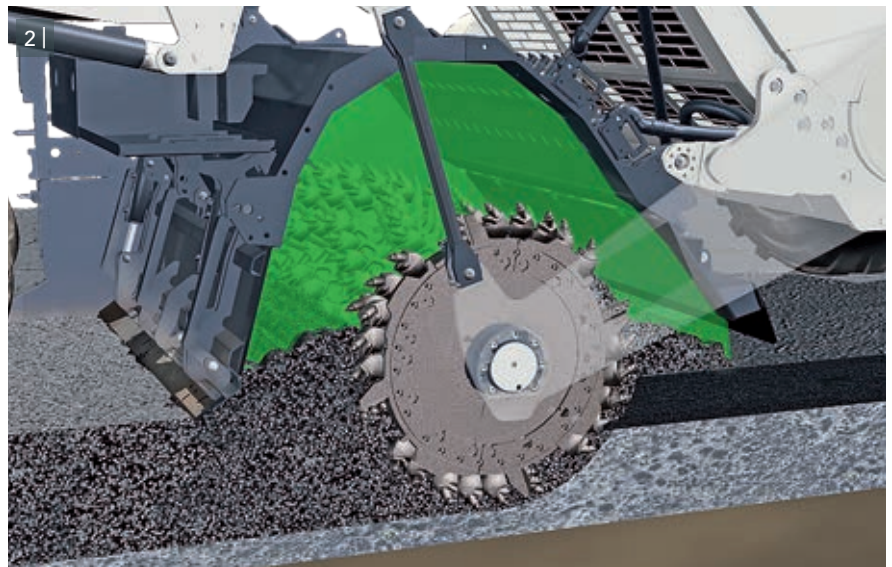
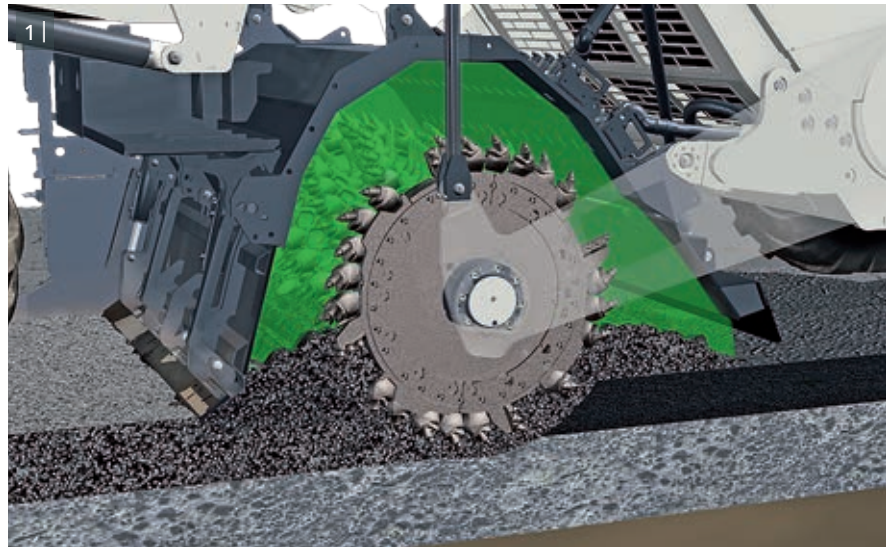

**1 |** Small mixing chamber when operating at shallow working depths.

**2 |** Large mixing chamber when operating at high working depths.

**3-4 |** The front rotor plate opens wide and is equipped with a crusher bar which can be adjusted to produce the specified particle size.

**5-6 |** The pivoting scraper at the rear rotor plate maintains an ideal angle to the surface to ensure perfectly even levelling of the stabilized or recycled layer.

# Precise metering systems for binder addition

## MICROPROCESSOR-CONTROLLED ADDITION OF BINDERS

Simply keying in the specified parameters once is not enough to achieve high-quality mixing results as they need to be maintained for the entire duration of the stabilizing or recycling operation. The WR has all it takes to meet these requirements: the parameters are entered quickly and conveniently via a small number of controls in the left-hand arm console and via the control screen.

Clearly structured, self-explanatory menus enable individual pages to be called up quickly. Large, readily comprehensible display readouts keep the operator fully informed of current parameters during the stabilizing or recycling operation. If specific values require correction, these can be adjusted quickly and effortlessly.

Microprocessor-controlled flow meters govern the addition of water, bitumen emulsion or foamed bitumen. The binders are added in accordance with the previously specified parameters, such as working width, working depth, material density and machine advance rate. The injection bars are fitted with up to sixteen spray nozzles each which can be switched on or off separately at any time during the process to adjust the spraying width.



1 |



1 | At a glance: important machine parameters are permanently displayed in the bottom menu bar of the metering menu.



2 |



2 | The printer logs job data and input parameters.

3 | Parameters such as the spraying width and amounts of binder to be added can be adjusted intuitively.

3 |

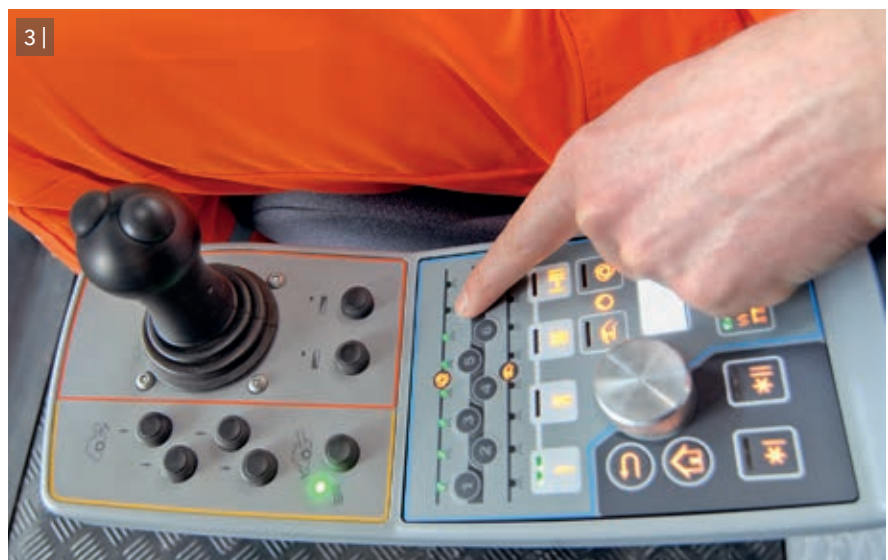

Working  
direction



- 1 | Feed hose for water
- 2 | Injection bar for water
- 3 | Injected water

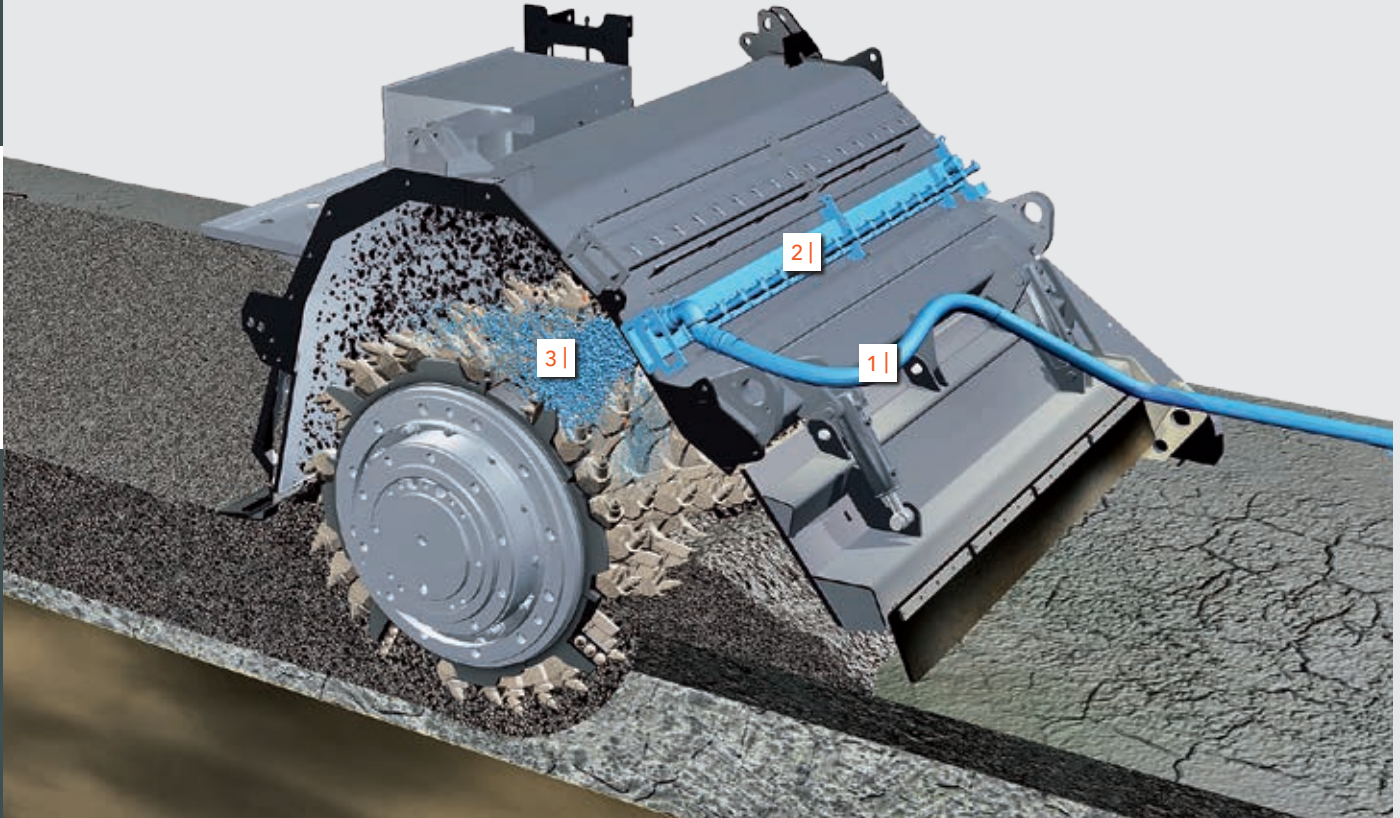

The microprocessor-controlled injection bar injects the specified amount of water into the mixing chamber.

## Precise metering systems for binder addition

### INJECTING WATER

Strict compliance with the specified binder amounts to be added is of paramount importance for high-quality stabilizing and recycling operations. The WR is fully equipped to meet these requirements: robust, microprocessor-controlled injection systems can be relied

on to precisely govern the addition of water, bitumen emulsion or foamed bitumen.

Several injection bars can be installed and several additives injected simultaneously in accordance with application requirements. In addition, a special quick-mounting feature enables the injection bars to be installed or removed quickly and effortlessly.

All hose connections are arranged at the front cross member.





Working  
direction

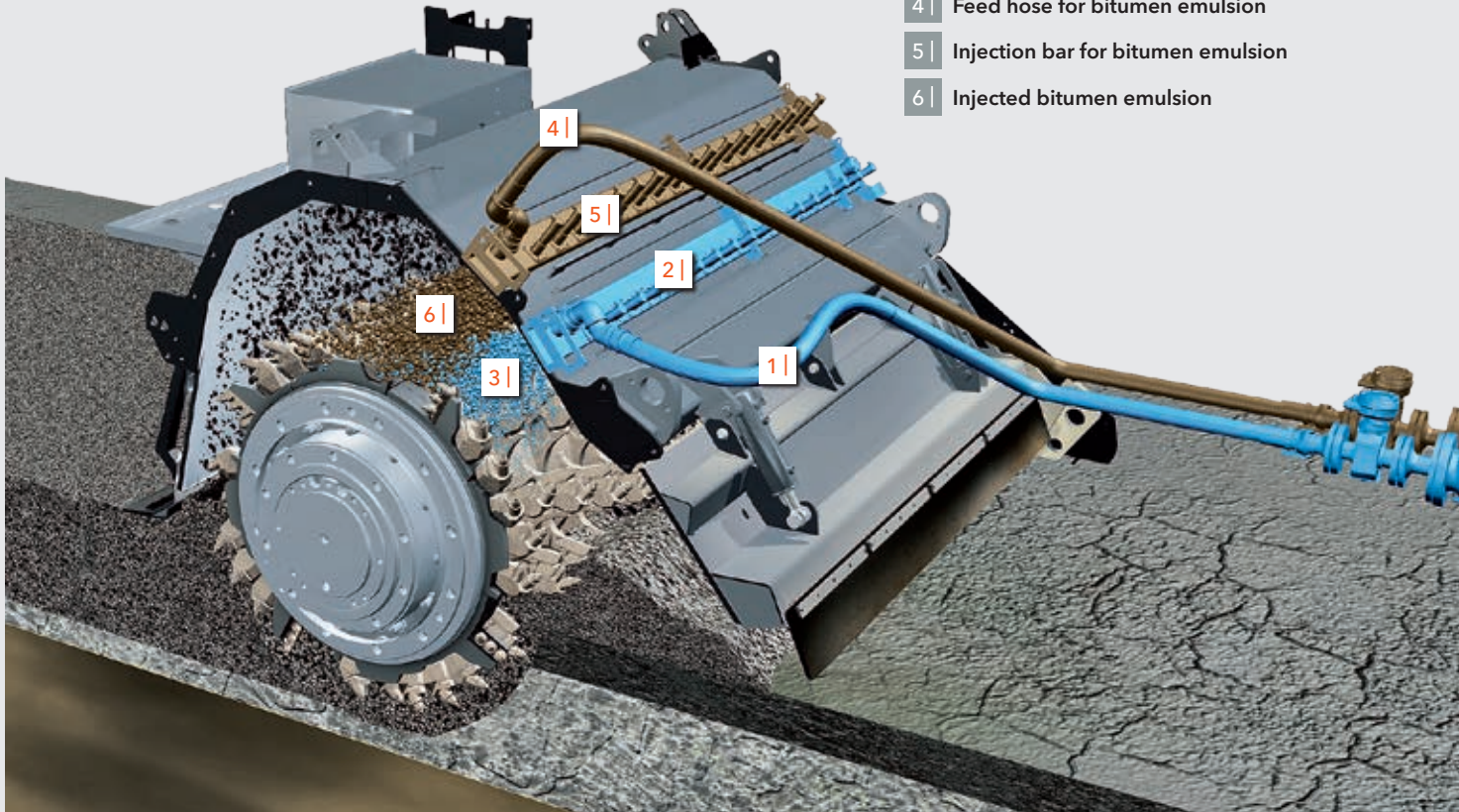

- 1 | Feed hose for water
- 2 | Injection bar for water
- 3 | Injected water
- 4 | Feed hose for bitumen emulsion
- 5 | Injection bar for bitumen emulsion
- 6 | Injected bitumen emulsion

*Two injection bars can be operated simultaneously when adding water and bitumen emulsion.*

## INJECTING WATER AND BITUMEN EMULSION

Tanker trucks driving ahead deliver water and bitumen emulsion to the injection bars via feed hoses connected to the recycler. The microprocessor-controlled injection bars for water and bitumen emulsion are of identical design and can be used for both substances to comply with application requirements.

Bitumen emulsion improves the flexibility of the new base layer and reduces cracking. The optimum moisture content is achieved by simultaneously adding water to the process.

*Readily accessible connections for water and bitumen emulsion.*



Working direction



- 1| Feed hose for water
- 2| Injection bar for water
- 3| Injected water
- 4| Feed hose for hot bitumen
- 5| Injection bar for hot bitumen
- 6| Expansion chambers for the foaming process
- 7| Injected foamed bitumen

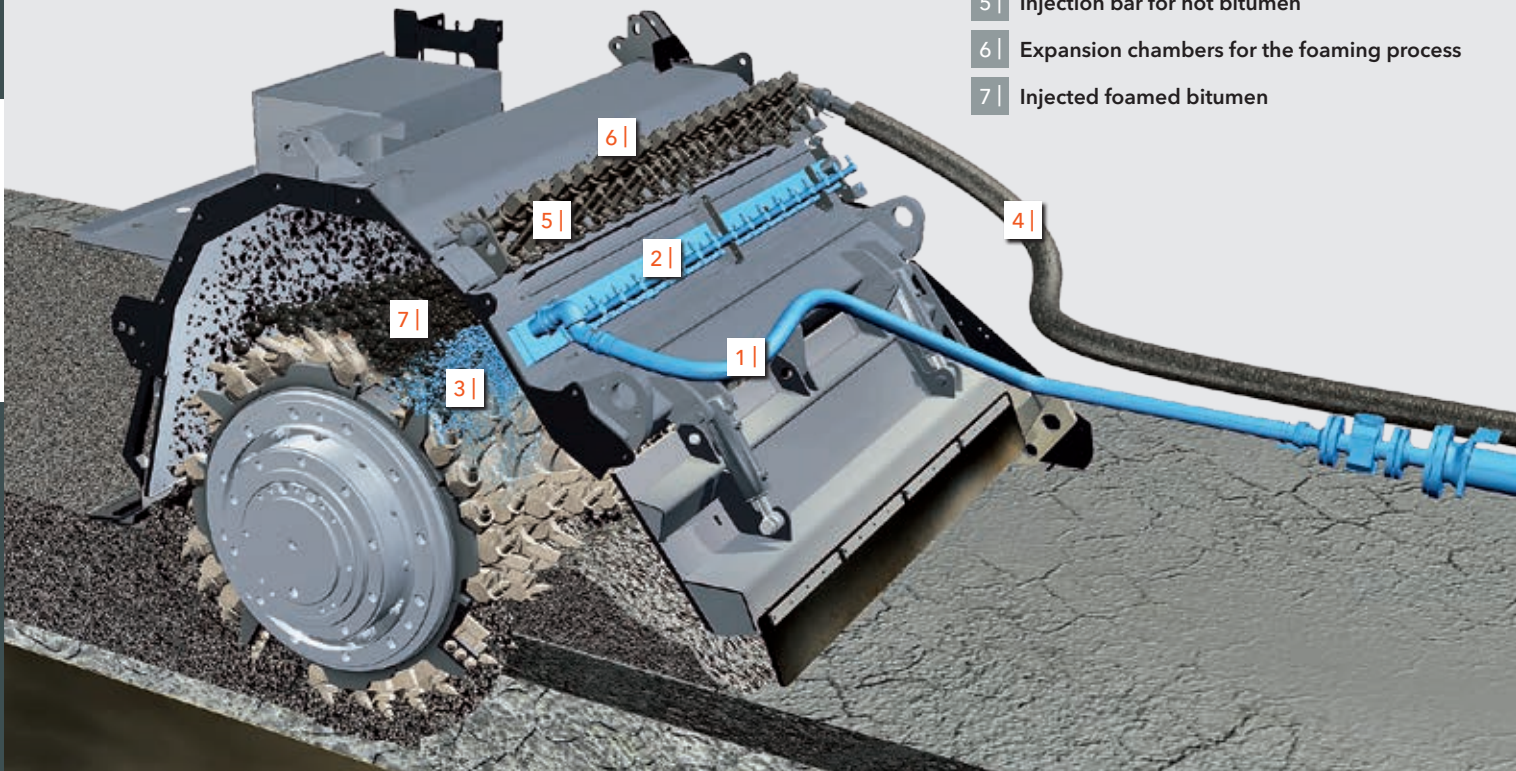

The microprocessor-controlled injection bar injects foamed bitumen into the mixing chamber in precisely metered quantities.

## Precise metering systems for binder addition

Hot bitumen is foamed by injecting metered quantities of water and compressed air.

### INJECTING WATER AND FOAMED BITUMEN

For base layers of exceptionally high quality, the WR produces foamed bitumen in up to sixteen separate expansion chambers by injecting small amounts of water and compressed air into hot bitumen which has a temperature of approx. 180°C.

The hot bitumen then foams abruptly, expanding to many times its original volume. In this state, the foamed bitumen disperses very evenly in the mineral aggregate mix to be recycled.

All components carrying hot bitumen are heated and kept at operating temperature, thus dispensing with the need to flush the system. All benefits considered, foamed bitumen is an exceedingly cost-efficient binder.

A test nozzle offers ready access for continuous monitoring of the foam quality during the recycling operation.

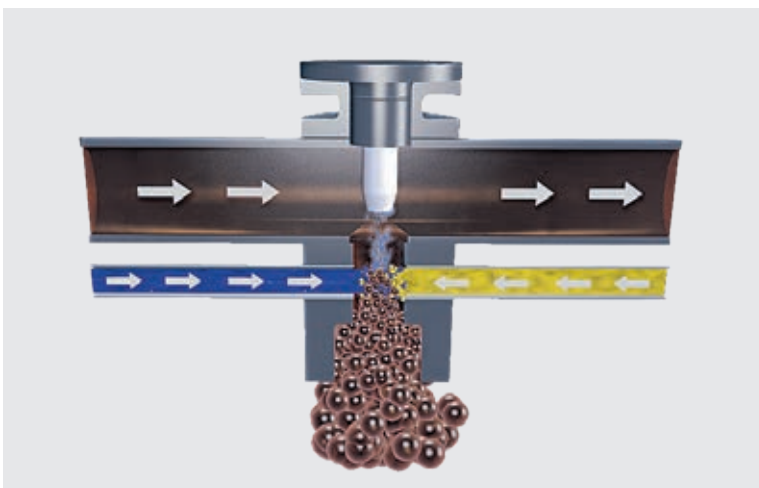

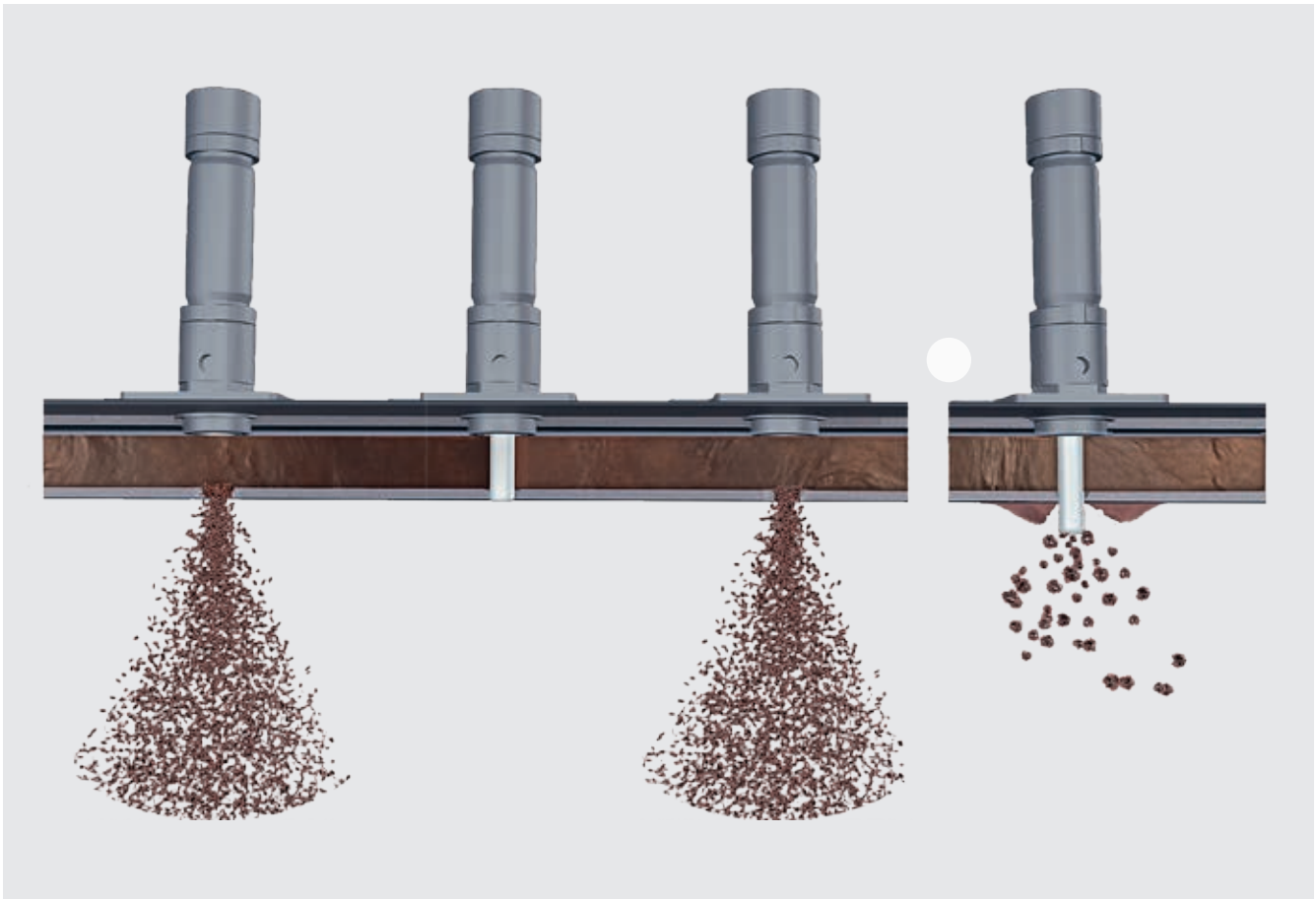

**SELF-CLEANING FEATURE COMES AS STANDARD**

Movable tappets automatically remove any binder build-ups occurring at the nozzle outlets during the recycling operation.

Regular self-cleaning of the spray nozzles via the tappets ensures precise metering across the entire working width. Cleaning of the nozzles is not only performed automatically at fixed time intervals but can also be conveniently activated manually via the screen whenever necessary.

Raising the revolving rotor to maximum height manually at the same time enables build-ups of encrusted material at the nozzle outlets to be removed.

*Self-cleaning feature: the tappets remove any material build-ups at the nozzle outlets.*

*Individual tappets clean the up to sixteen nozzles at predetermined intervals.*



# Precise metering systems for binder addition

## INTEGRATED BINDER SPREADER

The "S-Pack" (Spreader-Pack), which can be integrated in the WR 240, WR 240i or WR 250 as an optional feature, is the ideal candidate for the dustless addition of binding agents in cold recycling or soil stabilization. Lime or cement is spread right in front of the milling and mixing rotor in a microprocessor-controlled operation. "S-Pack" is synonymous with the reliable and dustless processing of binders especially on motorways, in industrial estates specifying strict emission requirements, residential areas or nature reserves.

The "S-Pack" spreader is loaded to capacity in less than five minutes. A standard 27-tonne silo transporter is emptied within two hours. The spreading process is controlled and monitored intuitively via the integrated control screen.

The outstanding all-terrain mobility of the WR model series now allows binders to be spread safely and precisely even on insufficiently stable ground.

1 | *Dustless, highly precise spreading of binders regardless of weather conditions.*



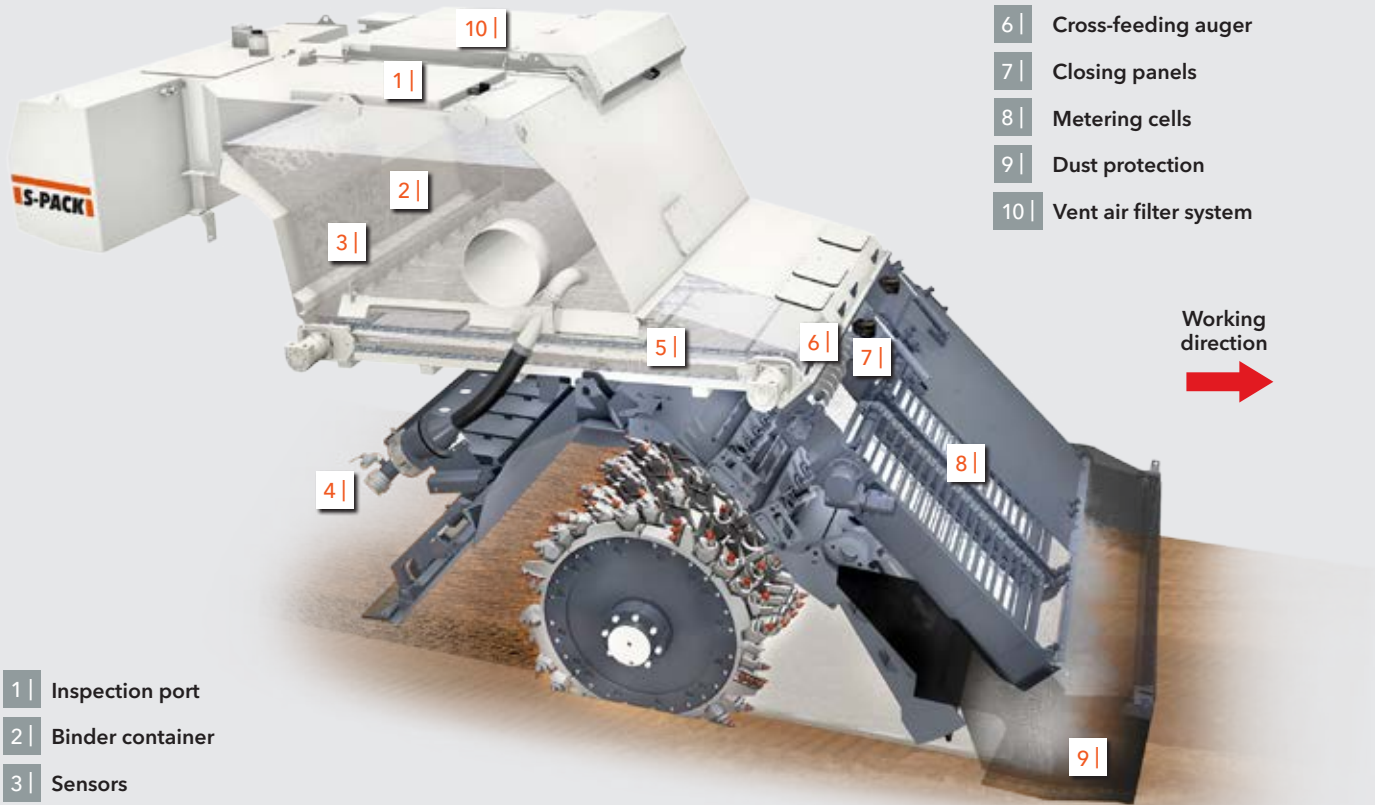

- 6 | Cross-feeding auger
- 7 | Closing panels
- 8 | Metering cells
- 9 | Dust protection
- 10 | Vent air filter system

- 1 | Inspection port
- 2 | Binder container
- 3 | Sensors
- 4 | Filling port with shut-off valve
- 5 | Conveying unit



2 | Easy, intuitive operation and diagnostic procedures via the control screen installed in the operator's cabin.

3 | The container is loaded with binder in a matter of mere minutes.



# Technical specification

54  
55

	WR 200	WR 200i
<b>Milling and mixing rotor</b>		
Working width	2,000 mm	
Working depth*	0-500 mm	
Tool spacing	20 mm	
Number of tools	150	
Drum diameter with tools	1,480 mm	
<b>Engine</b>		
Manufacturer	Mercedes Benz	Mercedes Benz/MTU
Type	OM 460 LA	OM 470 LA/6R 1100
Number of cylinders	6	
Power	at 2,000 min <sup>-1</sup> : 305 kW/409 HP/415 PS	at 1,900 min <sup>-1</sup> : 308 kW/412 HP/418 PS
Maximum power	at 1,800 min <sup>-1</sup> : 315 kW/422 HP/428 PS	at 1,700 min <sup>-1</sup> : 320 kW/429 HP/435 PS
Displacement	12.8 l	10.7 l
Fuel consumption, full load	80 l/h	75 l/h
Fuel consumption in field mix	39 l/h	35 l/h
Emission standards	EC Stage 3a/US Tier 3	EC Stage 4/US Tier 4f
<b>Electrical system</b>		
Electrical power supply	24 V	
<b>Filling capacities</b>		
Fuel tank	830 l	
Fuel tank when fitted with "S-Pack" option	-	
AdBlue®/DEF tank	-	80 l
Hydraulic oil tank	200 l	
Binder container	-	
Water tank	380 l	
Additional water tank	-	
<b>Driving properties</b>		
Working speed in milling and travel gear	0-210 m/min (12.6 km/h)	
Lateral inclination, max.	8°	
Ground clearance	approx. 400 mm	
<b>Tyres</b>		
Tyre size, front/rear	620/75 R26	
<b>Shipping dimensions</b>		
Dimensions for truck transport (L x W x H)	9,160 x 2,550 x 3,000 mm	
Dimensions for truck transport when fitted with "S-Pack" option (L x W x H)	-	

\* = The maximum working depth may deviate from the value indicated due to tolerances and wear

	WR 240	WR 240i	WR 250
	2,400 mm		2,400 mm
	0-510 mm		0-560 mm
	20 mm		30 mm x 2
	170		208
	1,480 mm		1,480 mm
	Cummins		Caterpillar
	QSX 15		C18 ATAAC
	6		6
	at 2,100 min <sup>-1</sup> : 447 kW/600 HP/608 PS		at 2,100 min <sup>-1</sup> : 571 kW/766 HP/777 PS
	at 1,900 min <sup>-1</sup> : 455 kW/610 HP/619 PS		at 1,800 min <sup>-1</sup> : 571 kW/766 HP/777 PS
	15.0 l	14.9 l	18.1 l
	120 l/h	115 l/h	142 l/h
	60 l/h	55 l/h	70 l/h
	EC Stage 3a/US Tier 3	EC Stage 4/US Tier 4f	no EC regulation/US Tier 2
	24 V		
	1,500 l	1,380 l	1,500 l
	1,300 l	1,180 l	1,300 l
	-	100 l	-
	320 l		
	5,5 m <sup>3</sup>		
	500 l		
	950 l		
	0-210 m/min (12.6 km/h)		
	8°		
	approx. 400 mm		
	28L-26		
	9,230 x 3,000 x 3,000 mm		
	9,680 x 3,000 x 3,080 mm		

# Technical specification

56  
57

	WR 200	WR 200i
<b>Weight of base machine</b>		
Empty weight of machine in standard design excluding tank contents	23,500 kg	23,800 kg
Operating weight, CE*	24,200 kg	24,500 kg
Operating weight, max. (full tanks, max. weight of additional equipment features)	26,500 kg	26,800 kg
<b>Weights of tank contents</b>		
Water tank filling in kg	380 kg	
Additional water tank filling in kg	-	
Diesel tank filling in kg (0.83 kg/l)	690 kg	
Diesel tank filling in kg when fitted with "S-Pack" option (0.83 kg/l)	-	
AdBlue®/DEF tank filling in kg	-	80 kg
Filling of binder container (S-Pack) in kg	-	
<b>Additional add-on weights</b>		
<b>Driver and tools</b>		
Driver	75 kg	
5 cutting tool containers	125 kg	
<b>Injection system in lieu of standard</b>		
<b>Single ESL:</b> Injection system for water or bitumen emulsion	450 kg	
<b>Dual ESL:</b> Injection system for water and bitumen emulsion	760 kg	
<b>ESL foamed bitumen:</b> Injection system for water and foamed bitumen	1,310 kg	
<b>ESL 1800 L:</b> Injection system for water, 1,800 l/min	410 kg	
Integrated binder spreader (S-Pack) including vent air filtering	-	
<b>Additional equipment</b>		
Additional water tank (empty)	-	

\* = Machine in standard design, half-full water tank, half full AdBlue® tank, half-full fuel tank, driver (75 kg), on-board tools



	WR 240	WR 240i	WR 250
	29,000 kg	29,600 kg	30,750 kg
	30,000 kg	30,600 kg	31,700 kg
	40,400 kg	41,000 kg	43,100 kg
	500 kg		
	950 kg		
	1,245 kg	1,145 kg	1,245 kg
	1,070 kg	970 kg	1,070 kg
	-	100 kg	-
	5,000 kg		
	75 kg		
	125 kg		
	390 kg		
	720 kg		
	1,400 kg		
	390 kg		
	3,800 kg		
	420 kg		

# Dimensions

## WR 200/WR 200i

58  
59

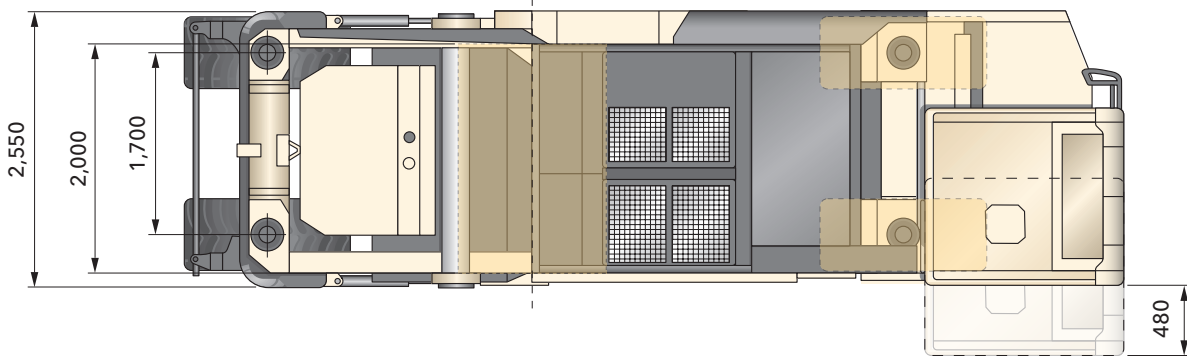
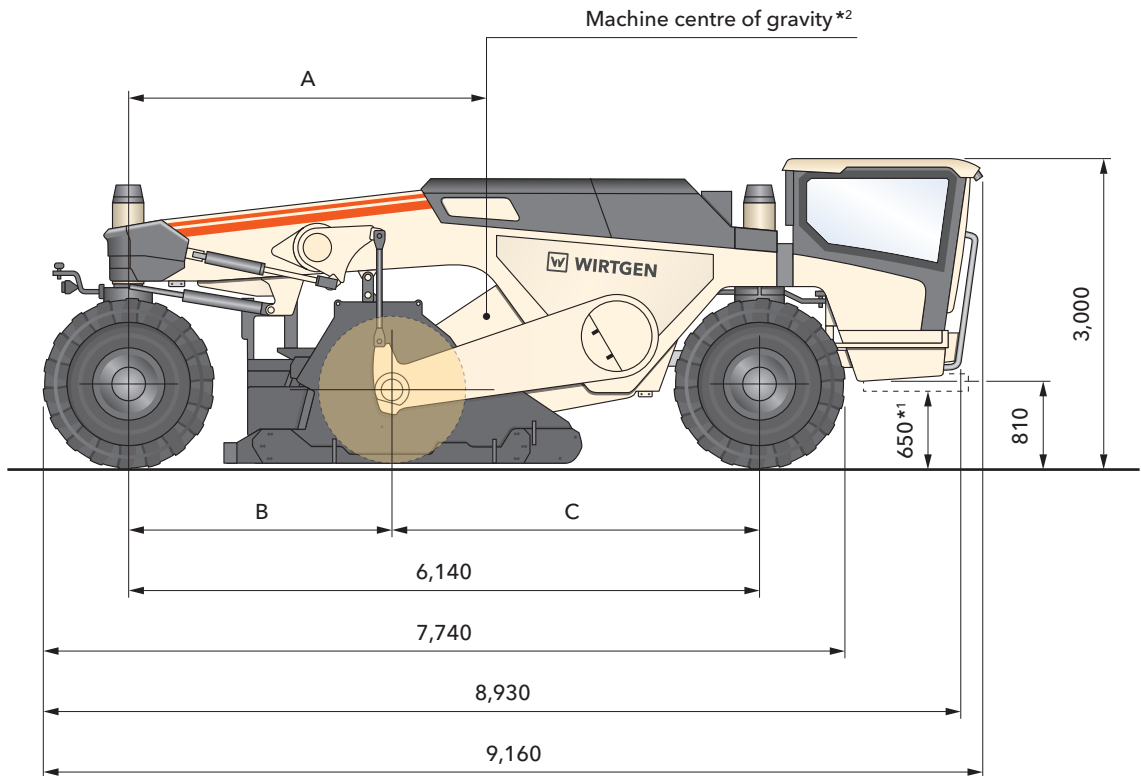

\*1 = Including injection system  
\*2 = Based on operating weight, CE

	A	B	C
WR 200/WR 200i	3,470	2,540	3,600

# Dimensions

## WR 240/WR 240i and WR 250

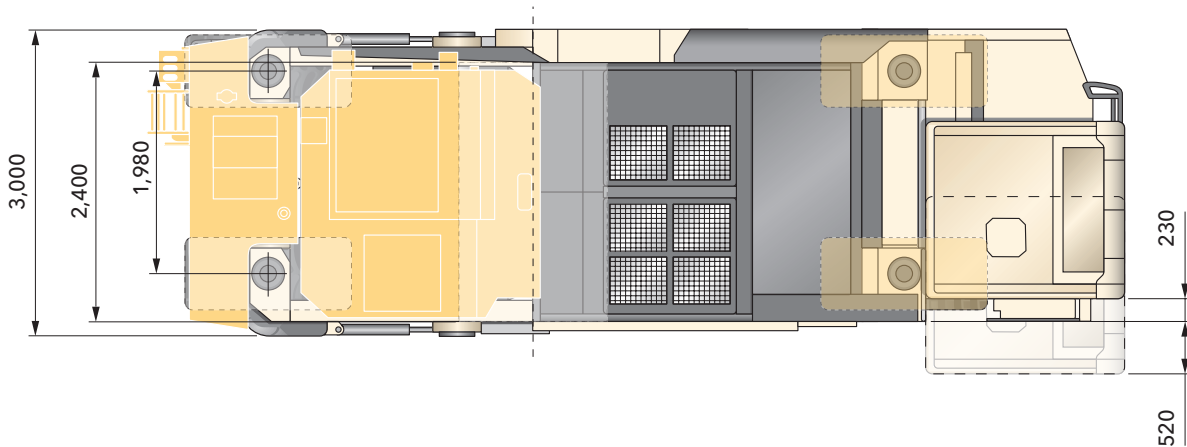
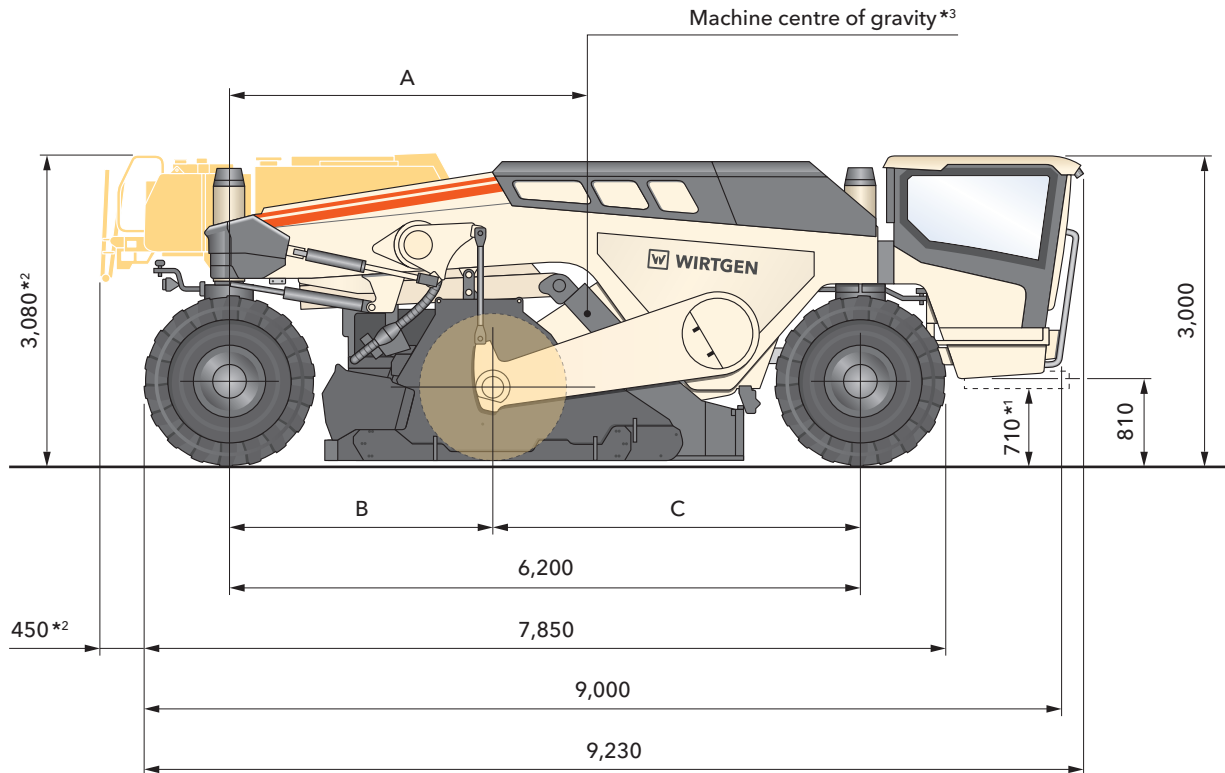

\*<sup>1</sup> = Including injection system  
 \*<sup>2</sup> = Including "S-Pack"  
 \*<sup>3</sup> = Based on operating weight, CE

	A	B	C
WR 240/WR 240i	3,550	2,600	3,600
WR 250	3,500	2,550	3,650

Dimensions in mm

# Dimensions

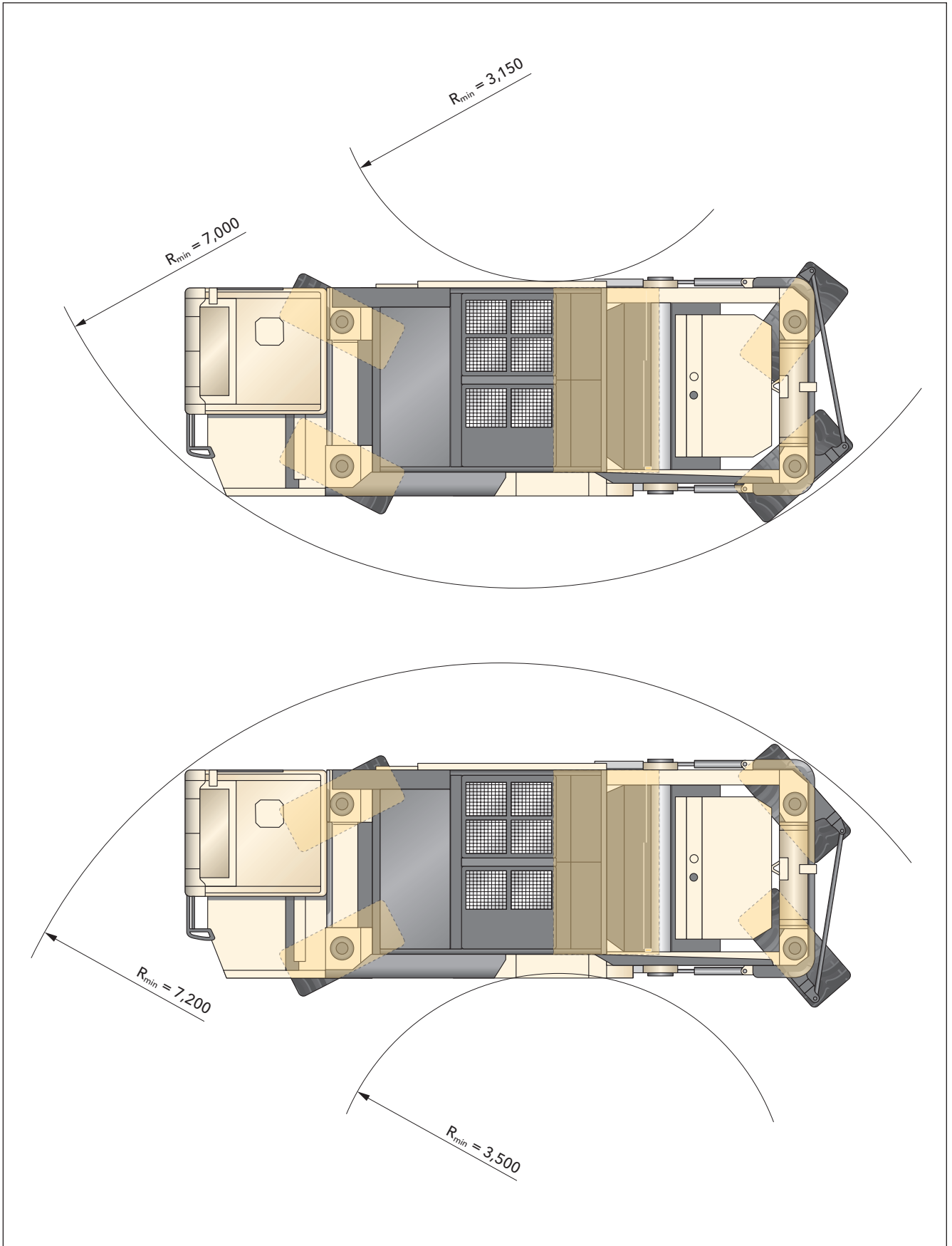

Turning radius of WR 200/WR 200i, WR 240/WR 240i and WR 250  
Dimensions in mm

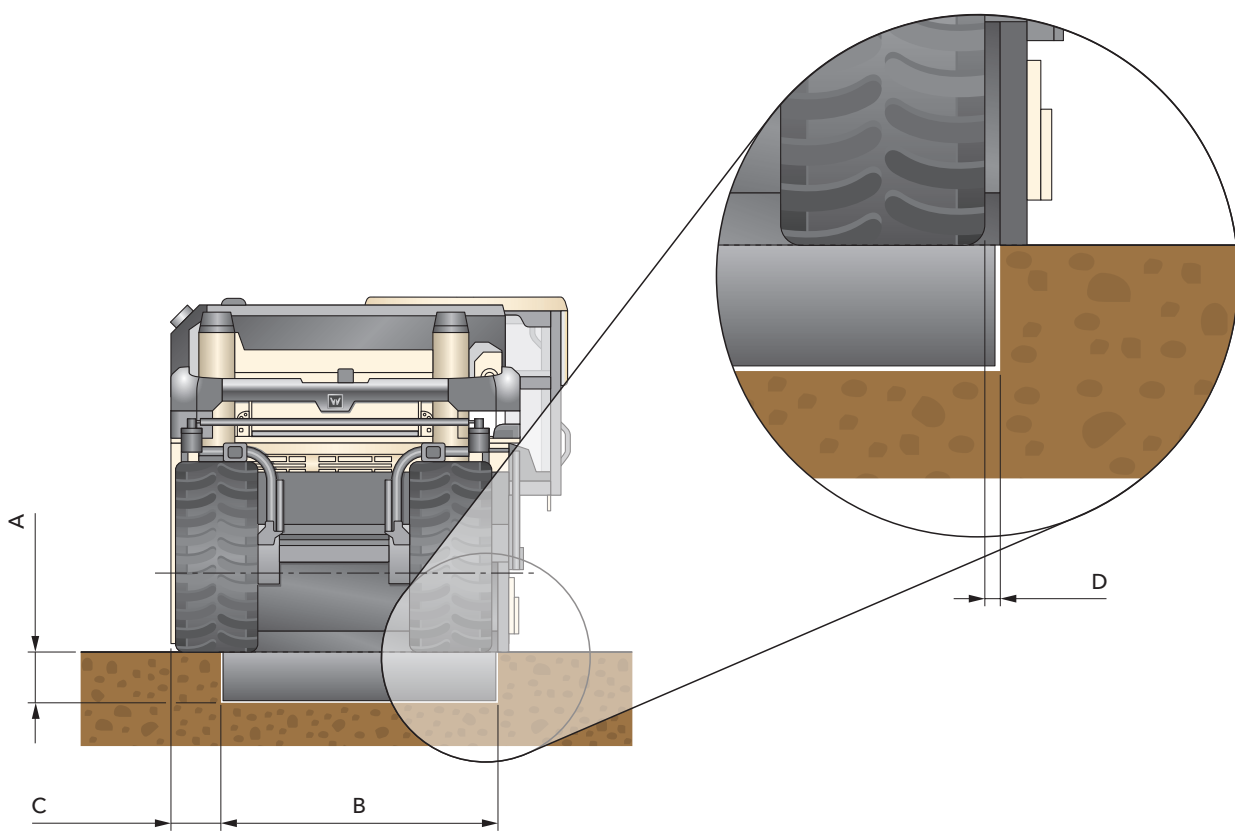







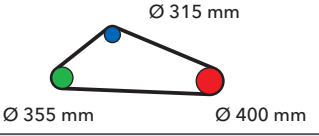
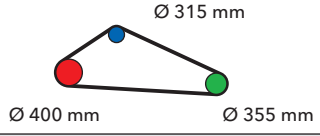
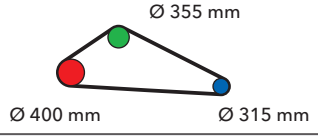

	A	B	C	D
WR 200/WR 200i	500	2,000	370	approx. 25
WR 240/WR 240i	510	2,400	420	approx. 50
WR 250	560	2,400	420	approx. 50

Rear view of WR 200/WR 200i, WR 240/WR 240i and WR 250  
 Dimensions in mm

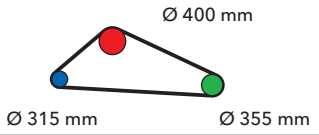
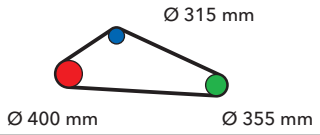
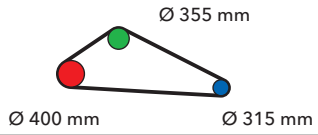
# Milling rotor speed

WR 200 / WR 200i, WR 240 / WR 240i











WR 200 / WR 200i	Engine speed			
		108 min <sup>-1</sup>	137 min <sup>-1</sup>	154 min <sup>-1</sup>
		117 min <sup>-1</sup>	149 min <sup>-1</sup>	168 min <sup>-1</sup>
		127 min <sup>-1</sup>	161 min <sup>-1</sup>	181 min <sup>-1</sup>
WR 240 / WR 240i	Engine speed			
		108 min <sup>-1</sup>	137 min <sup>-1</sup>	154 min <sup>-1</sup>
		120 min <sup>-1</sup>	153 min <sup>-1</sup>	172 min <sup>-1</sup>
		133 min <sup>-1</sup>	169 min <sup>-1</sup>	190 min <sup>-1</sup>

Milling rotor speed\* WR 200/WR 200i, WR 240/WR 240i

\* = The milling rotor speed depends on the engine speed setting

# Milling rotor speed

## WR 250

WR 250	Setting of drum gearbox	Engine speed	 Ø 355 mm      Ø 400 mm	 Ø 400 mm      Ø 355 mm
	WR 250			87 min <sup>-1</sup>
			97 min <sup>-1</sup>	124 min <sup>-1</sup>
			108 min <sup>-1</sup>	137 min <sup>-1</sup>
			129 min <sup>-1</sup>	164 min <sup>-1</sup>
			145 min <sup>-1</sup>	184 min <sup>-1</sup>
			160 min <sup>-1</sup>	203 min <sup>-1</sup>

Milling rotor speed\* WR 250

\* = The milling rotor speed depends on the engine speed setting

# Standard equipment

	WR 200	WR 200i	WR 240	WR 240i	WR 250
<b>Base machine</b>					
Basic machine with engine	■	■	■	■	■
Machine chassis with integrated water tank and free visibility onto the right milled edge	■	■	■	■	■
The right wheels are for working right up to the edges within the milling width	■	■	■	■	■
Diesel engine power controller for optimum milling and mixing result	■	■	■	■	■
Engine cooling system with temperature-controlled fan speed	■	■	■	■	■
Air system with compressor max. 8 bar	■	■	■	■	■
Lockable, engine cover with integrated sound insulation package	■	■	■	■	■
Mechanical milling drum drive via a drive belt with automatic belt tensioner	■	■	■	■	■
Variable cutting speed by combination of 3 selectable engine speeds and 3 adjustable drive belt pulley arrangements to achieve optimum working results	■	■	■	■	—
Variable cutting speed by a combination of 3 selectable motor speeds, 2 variable drive belt pulley arrangements and one milling drum gearbox with 2-gear stages for achieving optimum working results	—	—	—	—	■
Depending on the working direction possible synchronous rotation or counterrotating mode	■	■	■	■	■
Hydraulic adjustable milling drum flap front	■	■	■	■	■
Hydraulically adjustable scraper plates behind the drum	■	■	■	■	■
Infinitely variable working depth setting by lowering or raising of the complete milling drum	■	■	■	■	■
Automatic mixing space adaptation to the particular working depth (larger mixing space with lower working depth)	■	■	■	■	■
Milling drum rotation device with hydraulic milling drum drive for slowly turning the milling drum in the pick change	—	—	—	—	■
Power-controlled lowering speed of the milling drum in starting mode	■	■	■	■	■
<b>Milling and mixing rotor</b>					
Milling and mixing rotor FB2000 HT5 LA20 D22 with 150 picks	□	□	—	—	—
Milling and mixing rotor FB2400 HT22 LA20 D22 with 170 picks	—	—	□	□	—
Milling and mixing rotor FB2400 HT22 LA30x2 D22 with 208 picks	—	—	—	—	□
<b>Spraying unit/binding agent addition</b>					
Version without spraying system	□	□	□	□	□
Version without binder spreader device	—	—	□	□	□
Version without waste air filtering	—	—	□	□	□
<b>Machine control and levelling system</b>					
Multi-function control colour display showing important machine operating conditions	■	■	■	■	■
Extensive machine diagnosis in the control display	■	■	■	■	■
Programmable automatic system for initiating and completing the milling process at the particular working depth	■	■	■	■	■
Automatic functions for reducing the strain on the machine operator	■	■	■	■	■

- = Standard equipment
- = Standard equipment, replaceable with optional equipment
- = Optional equipment



	WR 200	WR 200i	WR 240	WR 240i	WR 250
<b>Operator's stand</b>					
Comfortable, high-quality cabin with flexible mountings, with roof hatch and individually adjustable heating	■	■	■	■	■
Ergonomic, air-cushioned operator's seat	■	■	■	■	■
Roll-over protection system (ROPS and FOPS) integrated in the cab frame	■	■	■	■	■
Large windows with optimum visibility of the particular working area and integrated window wipers	■	■	■	■	■
Recirculating and fresh air filters can be changed without tools	■	■	■	■	■
Various shelves and storage compartments as well as 12 V and 24 V sockets	■	■	■	■	■
The cabin can be pushed to the side over the right-hand side of the machine in order to gain a better overview of the machine	■	■	■	■	■
Rotation of the operator's stand through 90° offers optimum adaptation to the particular working situation	■	■	■	■	■
Individually adjustable control panel with colour display	■	■	■	■	■
Reversing camera with graphical reversing assistant	■	■	■	■	■
Mirrors on right and left in the the front area of the machine	■	■	■	■	■
Working lights integrated in the cab roof	■	■	■	■	■
Convenient, accessible footstep to the operator's stand	■	■	—	—	—
Folding footstepladder to the operator's stand	—	—	■	■	■
<b>Chassis and height adjustment</b>					
Infinitely adjustable, hydraulic all-wheel drive	■	■	■	■	■
Four-way penduluming of the lifting columns to compensate for unevennesses in the ground	■	■	■	■	■
Electrohydraulic, light all-wheel steering, with the "crab", "cornering" or "straight ahead" steering types	■	■	■	■	■
<b>Others</b>					
"Welcome-and-go-home light" function with LED lighting in the ladder area	■	■	■	■	■
Safety package with 3 emergency stop switches	■	■	■	■	■
Large tool package in lockable tool box	■	■	■	■	■
Machine preparation for installing the control unit for WITOS FleetView. "WIRTGEN Road Technologies Telematics and on-site Solutions" (WITOS) is the intelligent telematics system of the Wirtgen Road Technologies for efficient fleet and service management worldwide.	—	■	—	■	■
European type test certificate, Euro Test-mark and CE conformity	■	■	■	■	■
Paint standard cream white RAL 9001	□	□	□	□	□
Halogen lighting package 24 V with rotary beacons	□	□	□	□	□

- = Standard equipment
- = Standard equipment, replaceable with optional equipment
- = Optional equipment

# Optional equipment

	WR 200	WR 200i	WR 240	WR 240i	WR 250
<b>Milling and mixing rotor</b>					
Milling and mixing rotor FB2000 HT22 LA20 D22 with 150 picks	<input type="checkbox"/>	<input type="checkbox"/>	–	–	–
Milling and mixing rotor FB2000 HT22 LA20 D25 with 142 picks	<input type="checkbox"/>	<input type="checkbox"/>	–	–	–
Milling and mixing rotor FB2400 HT22 LA20 D25 with 162 picks	–	–	<input type="checkbox"/>	<input type="checkbox"/>	–
Milling and mixing rotor FB2400 HT22 LA30x2 D25 with 200 picks	–	–	–	–	<input type="checkbox"/>
<b>Spraying unit/binding agent addition</b>					
ESL 1-way: Spraying system for water or bitumen emulsion (800 l/min)	<input type="checkbox"/>	<input type="checkbox"/>	<input type="checkbox"/>	<input type="checkbox"/>	<input type="checkbox"/>
ESL 2-way: Spraying system for water and bitumen emulsion (2x 800 l/min)	<input type="checkbox"/>	<input type="checkbox"/>	<input type="checkbox"/>	<input type="checkbox"/>	<input type="checkbox"/>
ESL 2-way foam bitumen: Spraying system for water and foam bitumen (800 l/min, 500 kg/min)	<input type="checkbox"/>	<input type="checkbox"/>	<input type="checkbox"/>	<input type="checkbox"/>	<input type="checkbox"/>
A spraying system for water (1,800 l/min)	<input type="checkbox"/>	<input type="checkbox"/>	<input type="checkbox"/>	<input type="checkbox"/>	<input type="checkbox"/>
Version with integrated binder spreader device S-Pack	–	–	<input type="checkbox"/>	<input type="checkbox"/>	<input type="checkbox"/>
Manual waste air filtering S-Pack	–	–	<input type="checkbox"/>	<input type="checkbox"/>	<input type="checkbox"/>
Automatic waste air filtering S-Pack	–	–	<input type="checkbox"/>	<input type="checkbox"/>	<input type="checkbox"/>
External dosing control unit	<input type="checkbox"/>	<input type="checkbox"/>	<input type="checkbox"/>	<input type="checkbox"/>	<input type="checkbox"/>
<b>Machine control and levelling system</b>					
Slope control sensor	<input type="checkbox"/>	<input type="checkbox"/>	<input type="checkbox"/>	<input type="checkbox"/>	<input type="checkbox"/>
<b>Operator's stand</b>					
Air conditioner	<input type="checkbox"/>	<input type="checkbox"/>	<input type="checkbox"/>	<input type="checkbox"/>	<input type="checkbox"/>
Radio system with two loudspeakers and aerial	<input type="checkbox"/>	<input type="checkbox"/>	<input type="checkbox"/>	<input type="checkbox"/>	<input type="checkbox"/>
Additional monitor system with 3 cameras and monitor	<input type="checkbox"/>	<input type="checkbox"/>	<input type="checkbox"/>	<input type="checkbox"/>	<input type="checkbox"/>

- = Standard equipment
- = Standard equipment, replaceable with optional equipment
- = Optional equipment

	WR 200	WR 200i	WR 240	WR 240i	WR 250
<b>Others</b>					
Paint in one special colour (RAL)	<input type="checkbox"/>	<input type="checkbox"/>	<input type="checkbox"/>	<input type="checkbox"/>	<input type="checkbox"/>
Paint in two special colours (RAL)	<input type="checkbox"/>	<input type="checkbox"/>	<input type="checkbox"/>	<input type="checkbox"/>	<input type="checkbox"/>
Paint in maximum two special colours with substructure in special colour (RAL)	<input type="checkbox"/>	<input type="checkbox"/>	<input type="checkbox"/>	<input type="checkbox"/>	<input type="checkbox"/>
Powerful LED / halogen lighting package 24 V with rotary beacons	<input type="checkbox"/>	<input type="checkbox"/>	<input type="checkbox"/>	<input type="checkbox"/>	<input type="checkbox"/>
Printer for recording the job data	<input type="checkbox"/>	<input type="checkbox"/>	<input type="checkbox"/>	<input type="checkbox"/>	<input type="checkbox"/>
High-pressure water cleaner, 190 bar 15 l/min	<input type="checkbox"/>	<input type="checkbox"/>	<input type="checkbox"/>	<input type="checkbox"/>	<input type="checkbox"/>
Additional water tank, 950 litres	–	–	<input type="checkbox"/>	<input type="checkbox"/>	<input type="checkbox"/>
Battery operated hydraulic unit	<input type="checkbox"/>	<input type="checkbox"/>	<input type="checkbox"/>	<input type="checkbox"/>	<input type="checkbox"/>
Pneumatic hammer with pick ejector/insertor	<input type="checkbox"/>	<input type="checkbox"/>	<input type="checkbox"/>	<input type="checkbox"/>	<input type="checkbox"/>
Hydraulic pick ejector drift	<input type="checkbox"/>	<input type="checkbox"/>	<input type="checkbox"/>	<input type="checkbox"/>	<input type="checkbox"/>
Diesel tank filling pump with 7.5 m suction hose	<input type="checkbox"/>	<input type="checkbox"/>	<input type="checkbox"/>	<input type="checkbox"/>	<input type="checkbox"/>
Diesel filling Wiggins system	<input type="checkbox"/>	<input type="checkbox"/>	<input type="checkbox"/>	<input type="checkbox"/>	<input type="checkbox"/>
WITOS FleetView telematics system incl. 3-year operating period (EU)	–	<input type="checkbox"/>	–	<input type="checkbox"/>	<input type="checkbox"/>
WITOS FleetView telematics system incl. 3-year operating period (USA)	–	<input type="checkbox"/>	–	<input type="checkbox"/>	<input type="checkbox"/>
WITOS FleetView telematics system incl. 3-year operating period - PROMOTION	–	<input type="checkbox"/>	–	<input type="checkbox"/>	<input type="checkbox"/>
Hot bitumen hose 4", 4000 LG	<input type="checkbox"/>	<input type="checkbox"/>	<input type="checkbox"/>	<input type="checkbox"/>	<input type="checkbox"/>
Suction hose for water or emulsion	<input type="checkbox"/>	<input type="checkbox"/>	<input type="checkbox"/>	<input type="checkbox"/>	<input type="checkbox"/>
Connecting rod	<input type="checkbox"/>	<input type="checkbox"/>	<input type="checkbox"/>	<input type="checkbox"/>	<input type="checkbox"/>
Suspension tube in connection with WM 1000	–	–	<input type="checkbox"/>	<input type="checkbox"/>	<input type="checkbox"/>

= Standard equipment  
 = Standard equipment, replaceable with optional equipment  
 = Optional equipment



WIRTGEN GmbH  
Reinhard-Wirtgen-Str. 2 · 53578 Windhagen · Germany  
Phone: +49 (0)26 45/131-0 · Fax: +49 (0)26 45/131-392  
Internet: [www.wirtgen.com](http://www.wirtgen.com) · E-Mail: [info@wirtgen.com](mailto:info@wirtgen.com)

