

Compact Class

# **SUPER 1300-3i**

## **TRACKED PAVER**



Maximum pave width 5m  
Maximum laydown rate 350 tonnes/h  
Transport width 1.85m



## Compact and powerful – The tracked SUPER 1300-3i



**SUPER 1300-3i** is a highly versatile paver of the Compact Class which, thanks to its small size, can handle a wide range of highly varied surfacing tasks including combined footpaths and cycle paths, farm track applications or minor roadways. With pave widths extending from just 0.75m to 5m, the SUPER 1300-3i gets all these jobs done with ease.

The powerhouse is driven by a modern Deutz diesel engine rated at 80kW. The VÖGELE ErgoPlus 3 operating system has been supplemented by numerous ergonomic and functional features. The paver operator's console, for example, comes with a large colour display which provides brilliant readability even in poor lighting conditions.

The PaveDock Assistant and the AutoSet Basic repositioning function facilitate working with this compact powerhouse.

The paver can be combined with an AB 340 Extending Screed in TV version with tamper and vibrators for superb compaction. Heated electrically like all VÖGELE screeds, it raises standards in terms of performance and efficient electric power utilization.

# The highlights of the SUPER 1300-3i



**Tracked Compact Class paver** with a large range of applications for pave widths up to 5m

**Powerful and economical drive concept** with a modern Deutz diesel engine

**Optimum feeding with mix** thanks to the large material hopper and PaveDock Assistant communication system

**AutoSet Basic function** for a quick and safe relocation of the paver on the job site

**ErgoPlus 3 operating system** with numerous convenient and automatic functions

**AB 340 Extending Screed with tamper and vibrators** ensures a perfect paving result

## The right paver for jobs in tight spaces



**There is no component** on the SUPER 1300-3i that protrudes beyond its slim silhouette. With the hopper sides folded up, its basic width comes to no more than 1.85m – and this in conjunction with a length of just 4.95m. As a result, it can be driven nearly anywhere and fit through almost any gap. Yet it can still pave up to a width of 5m. No other paver in its class can match this.

» **The slim paver design** without protruding edges and an overall length of no more than 4.95m renders the machine ideal for easy paving and manoeuvring in tight corners.

» **For passing through narrow spaces,** push-rollers fold up together with the hopper sides.

» **The hardtop** of glass fibre-reinforced polymer material folds down with effortless ease, thus preparing the paver for transport quickly and easily.



# Range of applications of the VÖGELE Compact Class

With its compact dimensions and high power, the VÖGELE Compact Class of pavers offers a large range of different applications.

Whether combined foot and cycle paths, farm tracks or minor roads and open squares, the SUPER 1300-3i masters every job effortlessly, thanks to its large range of pave widths from 0.75m to 5m and high engine output.



ASPHALT PAVING ON COMBINED FOOT AND CYCLE PATHS



SURFACING PATHS IN PUBLIC PARKS



PAVEMENT REHABILITATION ON ACCESS ROADS



PAVEMENT REHABILITATION ON MUNICIPAL ROADS



ASPHALT PAVING ON SURFACES USED FOR INDUSTRIAL PURPOSES



ASPHALT PAVING ON RAILWAY PLATFORMS

The applications illustrated here are typical for the VÖGELE Compact Class. The illustrations may also show the predecessor model.

## The drive concept – Efficiency, performance and low consumption



**VÖGELE's modern drive concept** guarantees full power whenever it is needed. Superior technology also makes this Compact Class paver exceedingly economical in everyday use thanks

to the intelligent engine management with ECO mode and variable-speed fan. As a result, fuel consumption and the level of noise emitted by the SUPER 1300-3i are significantly reduced.

With their high traction, the crawler tracks of the SUPER 1300-3i perfectly combine excellent paving performance and maximum mobility during transport.

## Full power – Intelligent technology

**Three main components** define the power unit of a SUPER 1300-3i: its modern, liquid-cooled diesel engine, a splitter gearbox flanged directly to the engine and a large cooler assembly.

The driving force in this VÖGELE powerpack is its powerful Deutz diesel engine of type TCD 3.6L4. This four-cylinder engine delivers 80kW at 2,000rpm. Yet the fuel-saving ECO mode is sufficient for many applications. And even then, the SUPER 1300-3i still has a full 72kW at its disposal. Moreover, the machine generates even less noise when running at just 1,600rpm.

A large cooler assembly ensures that the power unit always delivers its full output. With innovative

air routing and a variable-speed fan, temperatures are continually maintained within the optimum range, significantly extending the service life of both the diesel engine and the hydraulic oil. A further advantage is that the machine can operate without difficulty in all climate regions worldwide.

All hydraulic consumers are directly supplied with hydraulic oil via the splitter gearbox. Hydraulic pumps and valves are centrally located, making them optimally accessible for servicing.

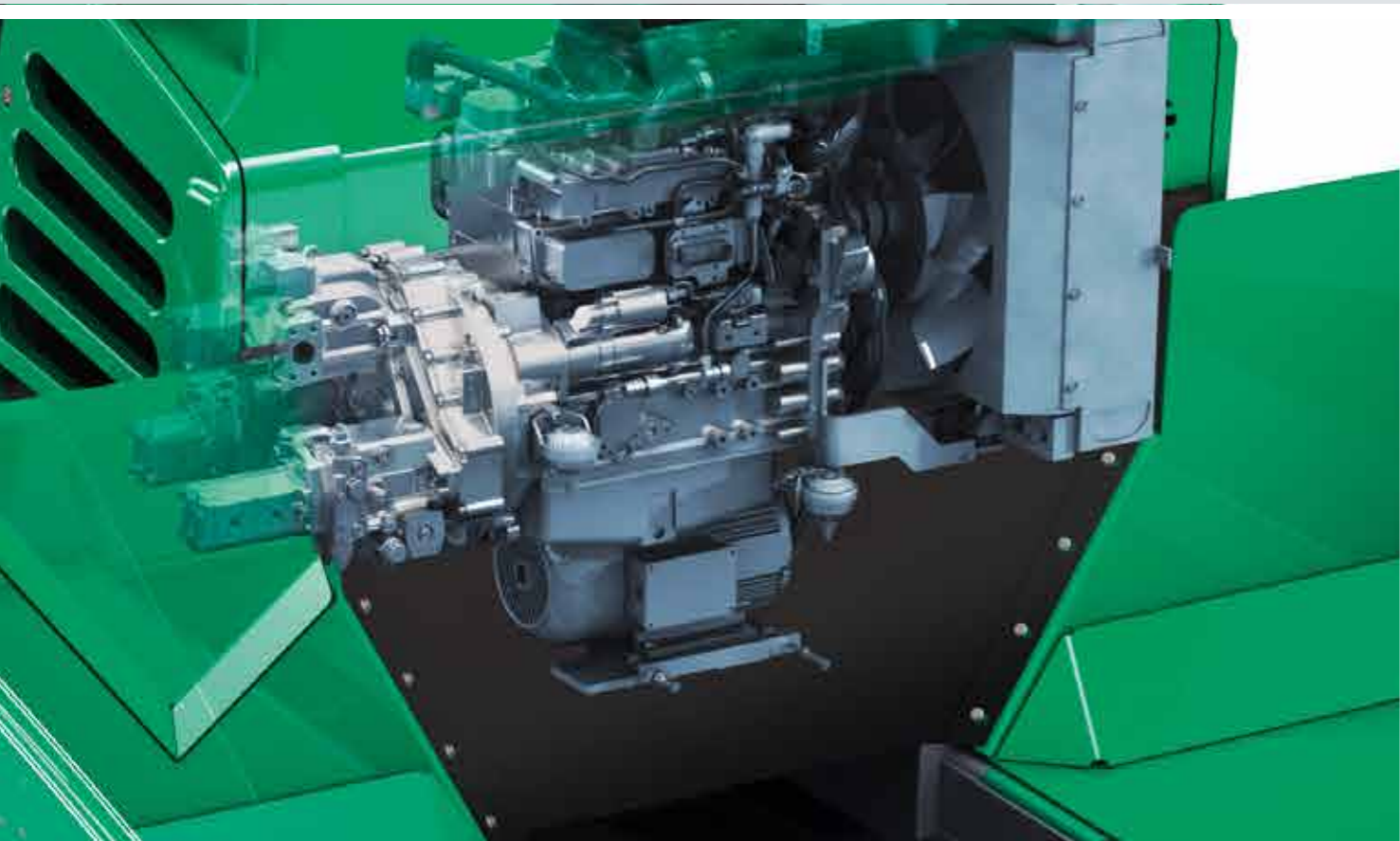

The large cooler assembly is made up of three parts. It ensures that engine coolant, charge air and hydraulic oil are maintained at the optimum temperature.

» **Machines with the suffix "i"** in their product designation are not only economical, but also extremely clean. The "i" stands for "intelligent emission control" and is found in the type names of all machines from the WIRTGEN GROUP equipped with the latest engine technology. Thanks to their sophisticated exhaust gas after-treatment, these engines comply with the strict requirements of European emissions standard Stage 3b as well as US EPA standard Tier 4i.

» **Powerful Deutz diesel engine** rated at 80kW.

» **ECO mode** (72kW at 1,600rpm) is sufficient for many paving applications.

The engine's noise emissions, which are already low, are further decreased when working in ECO mode. In addition, ECO mode reduces fuel consumption and wear.

» **A powerful three-phase A.C. generator** with generator management controls the output in compliance with the pave width. Heating the compacting systems to operating temperature takes a short time only.

» **For hydraulic functions**, powerful separate drives are installed, which operate in independent closed loops. This solution allows engine output to be transformed highly efficiently into hydraulic paver performance.

## Efficient translation of tractive power

Thanks to their high-quality separate hydraulic drives, our pavers operate exceedingly cost-efficiently, achieving a high level of performance. With its powerful crawler tracks, the SUPER 1300-3i easily pushes heavy

feed vehicles and advances well, even on soft bases, when paving in large widths. In terms of traction, too, the VÖGELE drive concept for tracked pavers leaves nothing to be desired.



- » **The hydraulic systems** for the traction drive, conveyors and augers as well as the compacting systems all operate in separate closed circuits for maximum efficiency.
- » **Long crawler tracks** with large ground contact provide for maximum tractive effort, allowing the paver to get on well at a constant speed even when operating on difficult terrain.

- » **Positive tracking** when moving straight and accurate cornering due to separate drive and electronic control provided for each crawler track.
- » **Thanks to powerful separate drives** fitted into the sprockets for crawler tracks, engine output is translated into pave speed with maximum efficiency.





# Perfect paving quality thanks to perfect material management



**A continuous flow of mix** is key to ensuring uninterrupted and high-quality paving. That is why we attach such importance to professional material management when designing our pavers.

All our development efforts focus on simple operation and the best possible overview for the paving team.

VÖGELE's PaveDock Assistant is an innovative solution standardizing and simplifying communication between the paver operator and driver of the feed vehicle.

## Easy and clean feeding with mix

**When feeding the paver with mix** becomes difficult on narrow job sites, then the large capacity of the SUPER 1300-3i's material hopper ensures that an optimal amount of mix is still supplied in front of the screed.

Separately folding hydraulic hopper sides guarantee consistent feeding with mix even when paving in asymmetrical widths. They enable the SUPER 1300-3i to pave smoothly along boundaries such as walls.



- » **The large material hopper** holding 10t is amply dimensioned so that a sufficient quantity of mix is stored at all times. There is no problem tiding over difficult situations such as paving under bridges, for instance.
- » **Thanks to a hydraulically operated hopper front** (option), no mix is spilled when feed lorries change. Inside the material hopper the mix is directed right onto the conveyors for complete emptying. No hand work with shovels is required.
- » **Oscillating push-rollers** allow for convenient and shock-free docking even of large feed vehicles.

## Perfect conveyance and spreading of mix, as in large pavers

**The conveyance and spreading of mix** in front of the screed is optimal thanks to the large conveyor tunnel, proportional control of conveyors and powerful augers. Furthermore, augers adjustable

in height and folding limiting plates for the auger tunnel allow the paver to be moved on the job site without a need for conversion. This saves time and money.

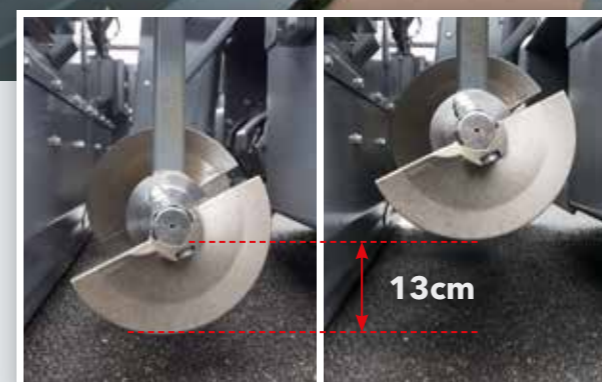

*Augers are infinitely variable in height by 13cm across the full pave width for optimal spreading of mix. Hydraulic auger height adjustment is available as an option.*

- » **Thanks to an amply dimensioned conveyor tunnel** and powerful, separate hydraulic drives provided for conveyors and augers, the SUPER 1300-3i achieves laydown rates up to 350t/h, an extraordinarily high performance for a paver in its class.

- » **Separate drive and control** is installed for each conveyor and each auger. When operating in Automatic mode, conveyors and augers are subject to continual monitoring. Proportional control provides for a constant head of mix in front of the screed.

- » **Folding limiting plates** for the auger tunnel are provided to quickly set up the machine for paving within the range of 2.6m and 4.2m. There is no need for conversion.

# PaveDock Assistant: The communication system

A constant feed of material is a fundamental prerequisite for high-quality paving and perfect evenness.

PaveDock Assistant is the communication system between the paver operator and the driver of the feed vehicle. It allows particularly fast and reliable transfer of mix to the paver.

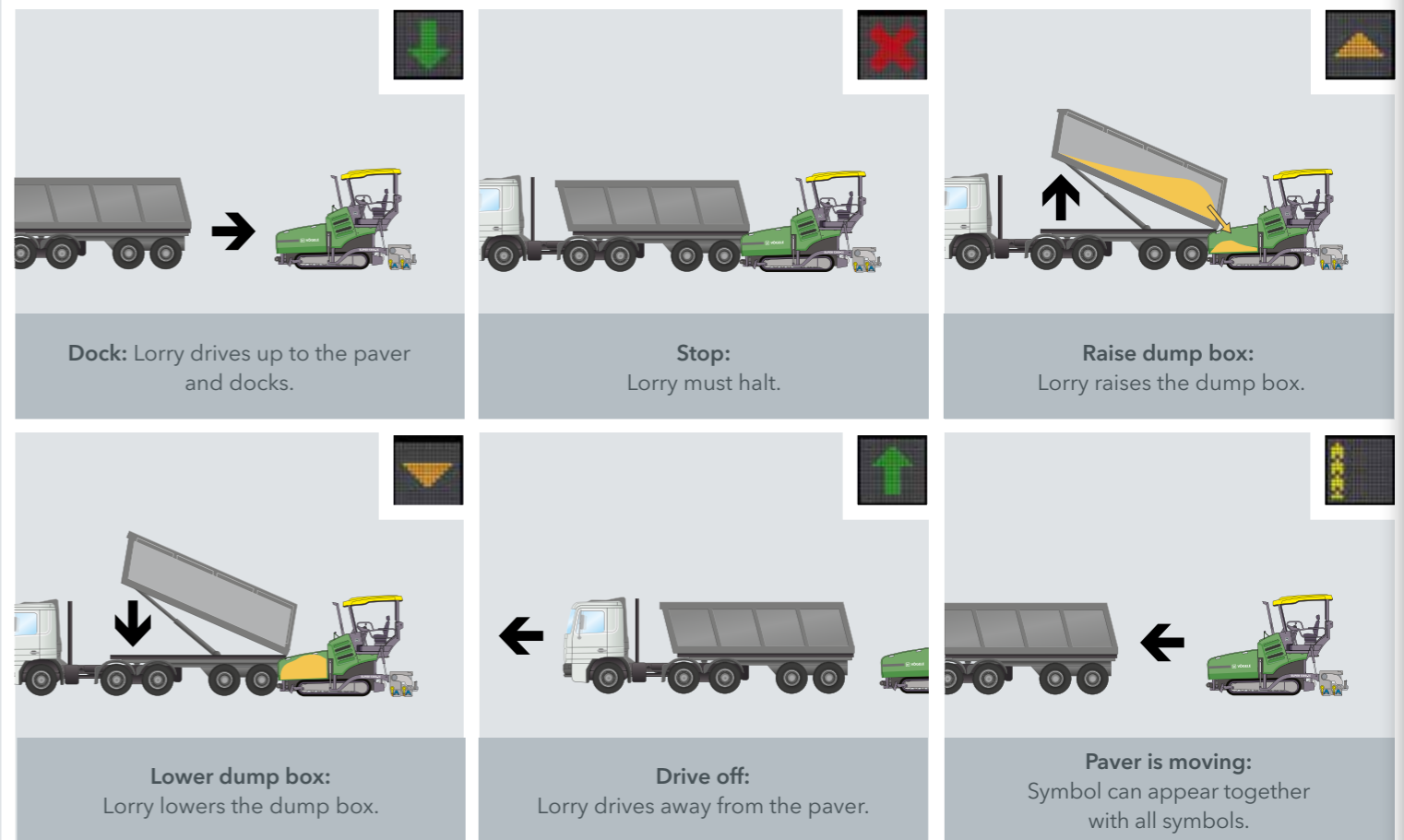

The core element of the PaveDock Assistant are the signal lights on the paver and the associated control elements on the paver operator's ErgoPlus 3 console.

The paver has two sets of signal lights, mounted on the right and left of the hardtop. With these lights, the paver operator can give the driver of the feed vehicle unmistakable signals, indicating what needs to be done (e.g. reverse, stop, dump mix). Having two lights, each in an elevated position, ensures that all signals are clearly visible to the feed vehicle driver from all angles of approach.

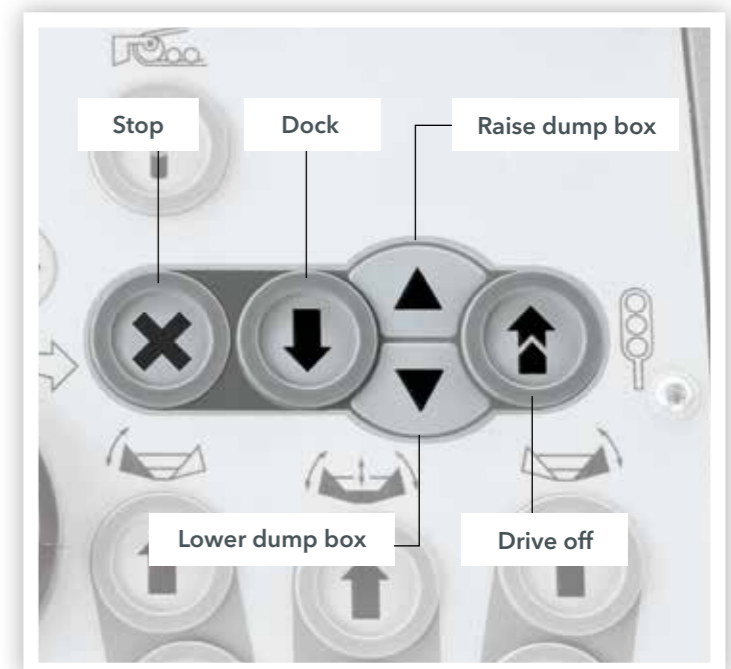

# AutoSet Basic

## Repositioning function

**AutoSet Basic** is especially helpful when the machine frequently has to be moved on the job site.

Simply pressing the "Execute" button hydraulically raises the augers, the hopper front and the deflectors in front of the crawler tracks to the uppermost positions. The screed, too, is brought into its transport position. The conveyors are temporarily reversed, preventing mix from falling to the ground when the paver travels to the next work section on site.

Once the paver has been repositioned, pressing the "Execute" button again returns all systems to the previously stored working position.

This ensures that no settings are lost when changing from paving to repositioning or transport. It also effectively prevents any damage to the machine.



THE AUTOSET BASIC REPOSITIONING FUNCTION IS ACTIVATED JUST BY PUSHING THE "EXECUTE" BUTTON.



RAISE / LOWER SCREED



RAISE / LOWER AUGER

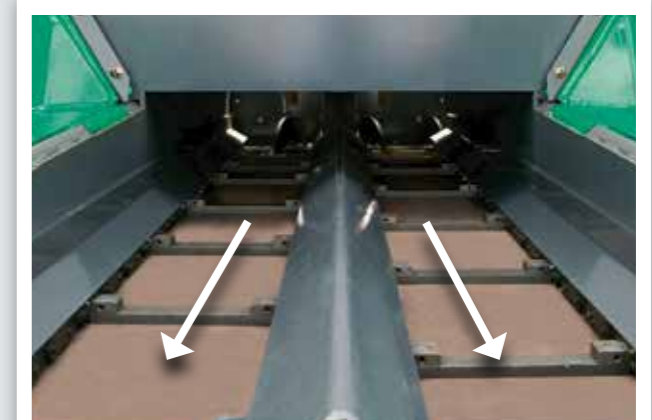

CONVEYOR MOVEMENT REVERSIBLE FOR A SHORT TIME

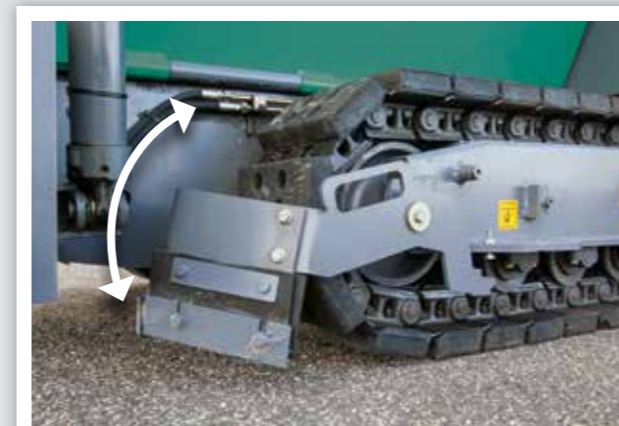

RAISE / LOWER DEFLECTORS IN FRONT OF THE CRAWLER TRACKS



RAISE HOPPER FRONT

## The ErgoPlus 3 operating concept

Even the very best machine with the most advanced technology can only really show its strengths if it can be operated easily and as intuitively as possible. At the same time, it should offer an ergonomic and safe working environment for the operating team. Therefore, the ErgoPlus 3 operating concept focuses on the operator. With VÖGELE pavers, the user consequently retains full control over the machine and construction project.

On the following pages example illustrations will provide you with more detailed information on the extensive functions of the ErgoPlus 3 operating concept. ErgoPlus 3 encompasses the operator's stand, the paver operator's console and screed consoles and Niveltronic Plus, the System for Automated Grade and Slope Control.



# The paver operator's **ErgoPlus 3** console



**“Full control for the machine operator”**

# The paver operator's ErgoPlus 3 console

The paver operator's console is extremely clear and has been designed according to practical principles. All functions are combined into logical groups, so that the operator finds each function exactly where he would expect it to be.

On the ErgoPlus 3 console, all push-buttons are easily identifiable by touch even when wearing work gloves. Once a button is pressed, off you go thanks to the "Touch and Work" principle. This means that a function is executed directly – without a need to confirm. As darkness falls, the paver operator's console is back-lit automatically, as in a car. This makes night-time work easy and relaxed.

**Reversing conveyor movement**

In order to avoid mix dropping from the conveyors during a move of the paver on the job site, conveyor movement can be reversed at the push of a button. Reverse movement, transferring mix from the rear of the conveyor tunnel back inside, takes place for a short time only and stops automatically.



**No-load function**

The no-load function is provided for the warm-up or cleaning of conveyors, augers and tamper.



**AutoSet Basic Repositioning function (option)**

With the AutoSet Basic Repositioning function, the paver is quickly and safely prepared for a move on the job site at the push of a button. After the move, all paver components are reset to their previous working positions, simply by pressing the button again. This ensures that no settings are lost when changing between "Pave" and "Job Site" modes. AutoSet Basic also effectively prevents damage during transport.



**Choice of operating modes for the paver**

All the main paving and machine functions can be controlled directly by individual push-buttons on the paver operator's ErgoPlus 3 console. By pressing the arrow buttons, up or down, the operator changes modes in the following order: "Neutral", "Job Site", "Positioning" and "Pave". An LED indicates the mode selected. When leaving "Pave" mode, a smart memory feature stores the last settings for paver functions so that, when resuming work after a relocation of the paver on the job site, these settings are restored automatically.



**Safe operation during the night**

Glarefree backlighting comes on automatically as darkness sets in so that the paver operator can also work safely on night-time jobs.



.....	<b>Module 1:</b>	Conveyors and augers, traction
.....	<b>Module 2:</b>	Screed
.....	<b>Module 3:</b>	Material hopper and steering
.....	<b>Module 4:</b>	Display for monitoring and adjustment of basic settings

**Display of the paver operator's console**

The redesigned colour display has a high-contrast user interface ensuring brilliant readability even in poor lighting conditions. Vital information is shown on menu level 1, such as the pave speed and the material level in the conveyor tunnel. Further paver functions such as tamper and vibrator speeds or auger feed rates can easily be set up via the display, too. And the display gives access to machine-related information such as fuel consumption or service hours.

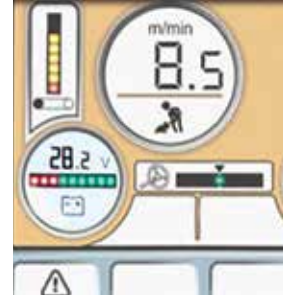

**PaveDock Assistant (option)**

With the PaveDock Assistant signal lights, the paver operator can give the driver of the feed vehicle unmistakable signals, indicating what needs to be done (e.g. reverse, stop, dump mix). The lights are conveniently activated directly from the paver operator's ErgoPlus 3 console.



**Choice of engine speed ranges**

For the engine, there is a choice of three modes to select from: MIN, ECO and MAX. To switch modes for engine rpm, all the operator needs to do is press the arrow buttons, up or down. In ECO mode, the engine delivers sufficient power for a great number of paving applications. Operating in ECO mode reduces noise emissions and fuel consumption considerably.



**Screed Assist (option)**

This button switches Screed Assist on (LED lights up) or off. Screed Assist pressure and balance can be set via the display. Screed Assist is active only when the screed is floating.



# The ErgoPlus 3 screed console



**The screed is crucial for pavement quality.** Therefore, easy and positive handling of all screed functions is of the utmost importance for high-quality road construction.

With ErgoPlus 3, the screed operator has the paving process at his fingertips. All functions are easily comprehensible and all controls are clearly arranged.

### The screed console

The screed console is designed in keeping with the conditions prevailing on the job site. Push-buttons are provided for the frequently used functions operated from the screed console. These are watertight and enclosed in palpably raised rings, so that they are identifiable blindfold simply by touch even when wearing work gloves. Important paver and screed data can be called up and adjusted from the screed console, too.



### The display of the screed console

The display of the screed console allows the screed operator to control and monitor both the left and the right side of the screed. Machine-related parameters such as tamper speed or conveyor speed can be adjusted conveniently via the display panel of the screed console. The clear menu structure, combined with easily understandable, self-explanatory symbols neutral in language, makes operating the display panel both simple and safe.



### Crown adjustment at the press of a button

The crown can be conveniently adjusted at the press of a button on the screed operator's console. When pressing the "plus" or "minus" keys, the set crown value is shown on the display.



### Ergonomic screed width control

The screed width can be effortlessly adjusted by means of the SmartWheel.



### Optimum visibility even in darkness

The screed console is specially designed for night-time operation. To prevent operator errors, the buttons are backlit as soon as dusk falls or in darkness. What's more, downward-angled high-power LED lighting gives the operator a perfect view of all processes associated with the side plate.





# VÖGELE Niveltronic Plus

**Niveltronic Plus**, the System for Automated Grade and Slope Control, is an in-house development by JOSEPH VÖGELE AG based on many years of experience in grade and slope control technology. Easy operation, precision and reliability are its hallmarks, ensuring perfect mastery of all grade and slope control jobs.

This fully integrated system is optimally adapted to the machine technology of the SUPER pavers. All wiring and connections, for instance, are integrated into the tractor unit and screed, effectively eliminating all risk of damage to these components.

VÖGELE naturally offer a particularly large and practical selection of sensors permitting versatile use of the Niveltronic Plus system. Whether car parks, roundabouts or highways need to be built or rehabilitated, VÖGELE offer the right sensor for every job site situation.

Sensors can be changed quickly and easily, for Niveltronic Plus automatically detects which sensor is connected, thus simplifying the configuration process for the user.



Left-hand side of screed	Right-hand side of screed
Shows the value specified for the sensor on the left-hand side. For grade sensors, values are indicated in mm. When working with the slope sensor, values are indicated in percent.	Shows the value specified for the sensor on the right-hand side. For grade sensors, values are indicated in mm. When working with the slope sensor, values are indicated in percent.
Shows the type of sensor selected for the left-hand side. Displayed here in this example is the symbol of the sonic sensor used in Ground mode.	Shows the type of sensor selected for the right-hand side. Displayed here in this example is the symbol of the sonic sensor used in Ground mode.
Shows the actual value picked up by the sensor.	Shows the actual value picked up by the sensor.
Shows the sensitivity set for the sensor selected.	Shows the sensitivity set for the sensor selected.





## The ErgoPlus 3 operator's stand

### 1. The comfortable operator's stand gives

an unobstructed view of all crucial areas on the paver such as material hopper, steering guide or screed. It allows the paver operator to closely monitor the feeding of the paver with mix.

### 2. The seats swinging out

to the sides and an operator's stand in a streamlined design provide for maximum visibility of the auger tunnel, permitting the paver operator to keep an eye on the head of mix in front of the screed at all times.

### 3. Working comfort

The paver operator's seat and console, as well as the screed consoles can now be adjusted even more easily to personal needs.

### 4. A place for everything and everything in its place

The operator's stand, with its streamlined design, is well organized, offering the paver operator a professional workplace. The operator's console can be protected by a shatter-proof cover to prevent wilful damage.

### 5. Hardtop gives excellent protection

The modern hardtop made of glass fibre-reinforced polymer material shelters the operator, come rain or shine.

### 6. Consistent service concept

All "Dash 3" pavers have a consistent maintenance concept with identical service intervals.

### 7. Safe and comfortable ascent

The walkway and comfortable middle ascent on the screed ensure safe and convenient access to the operator platform.

### 8. Ergonomic screed console

The height and position of the console are easily adjusted. The high-contrast colour display can be read clearly from all angles.



## AB 340 TV Screed

For the **SUPER 1300-3i**, the AB 340 Extending Screed in the TV version is the perfect match. The screed with a basic width of 1.8m extends hydraulically up to 3.4m. Through the addition of bolt-on extensions, it builds up to a maximum width of 5m.

**A typical VÖGELE feature** also found in the AB 340 TV Extending Screed is the powerful electric heating. The modern screed heating system provides for quick and uniform heating to operating temperature, an essential for smooth surface texture.

**The unique VÖGELE** single-tube telescoping system allows screed width control, accurate to the millimetre, up to 3.4m.

**Telescopic tubes** are located in high positions, so that any contact with hot mix is positively avoided, ensuring a long service life.

**Excellent insulation** of the screed plates reduces loss of heat to a minimum. Heating the screed takes a short time only, even with the engine running at minimum rpm.

**A homogeneous surface texture** is achieved due to uniform heating of screed plates and tamper bars.

**The electric heating** warms the screed up to its operating temperature much more quickly, even with the engine running at minimum rpm, thanks to intelligent generator management.

# The screed for the SUPER 1300-3i

## AB 340 TV

### Pave widths

- » Infinitely variable range from 1.8m to 3.4m.
- » Maximum pave width through bolt-on extensions:
  - > 3.9m (2 x 25cm)
  - > 4.5m (2 x 55cm)
  - > 5m (2 x 80cm)
- » Smaller widths by fitting cut-off shoes down to a minimum of 75cm.

### Compacting systems

- » AB 340 TV with tamper and vibrators



## AB 340 TV

AB 340 TV built up with 25cm bolt-on extensions

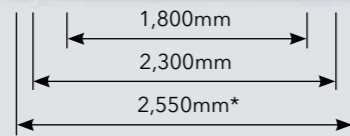

Easy transport  
\*Even with bolt-on extensions and side plates fitted, the transport dimensions do not exceed 2.55m.

## AB 340 TV

AB 340 TV built up with 80cm bolt-on extensions

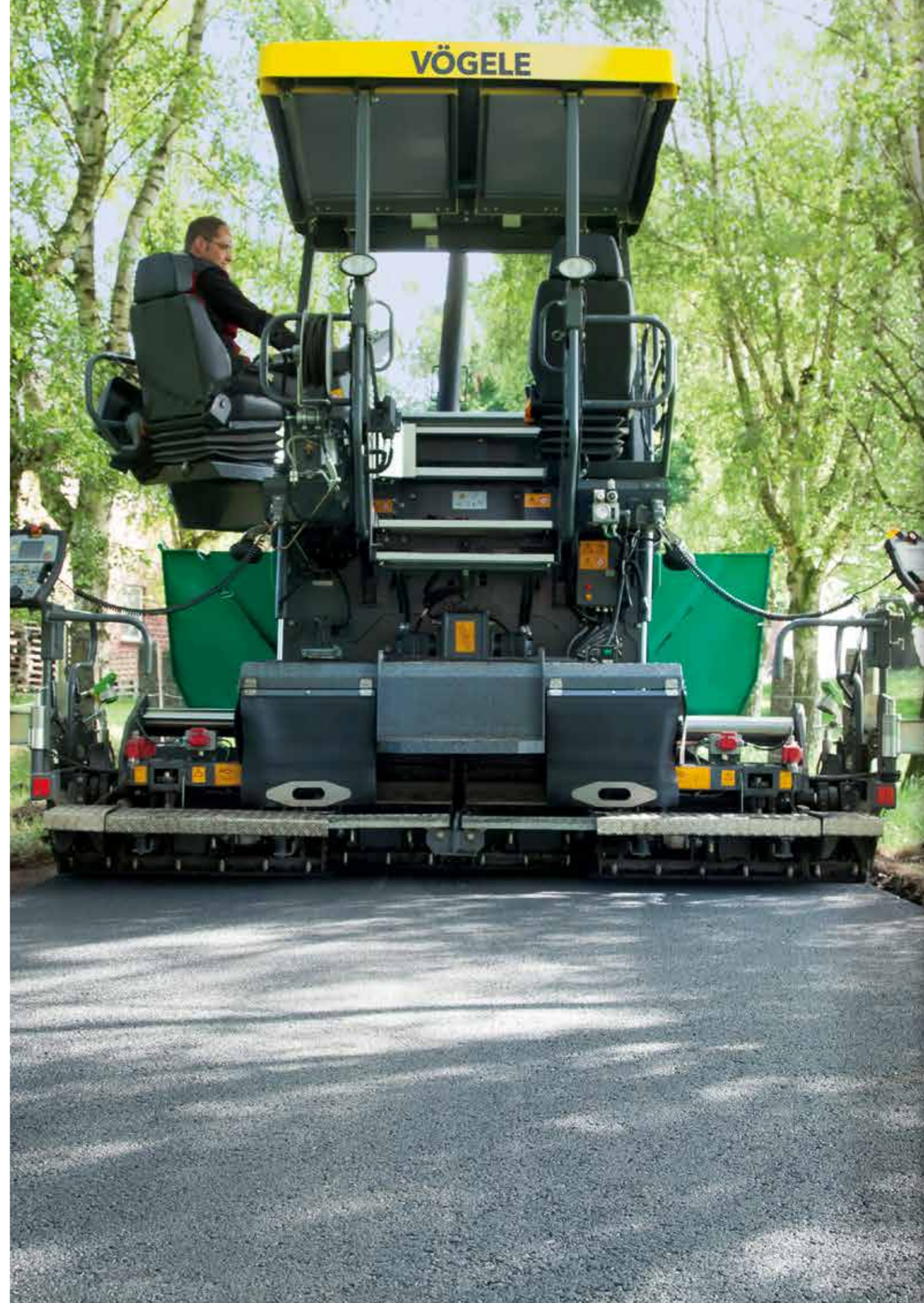

# All the facts at a glance

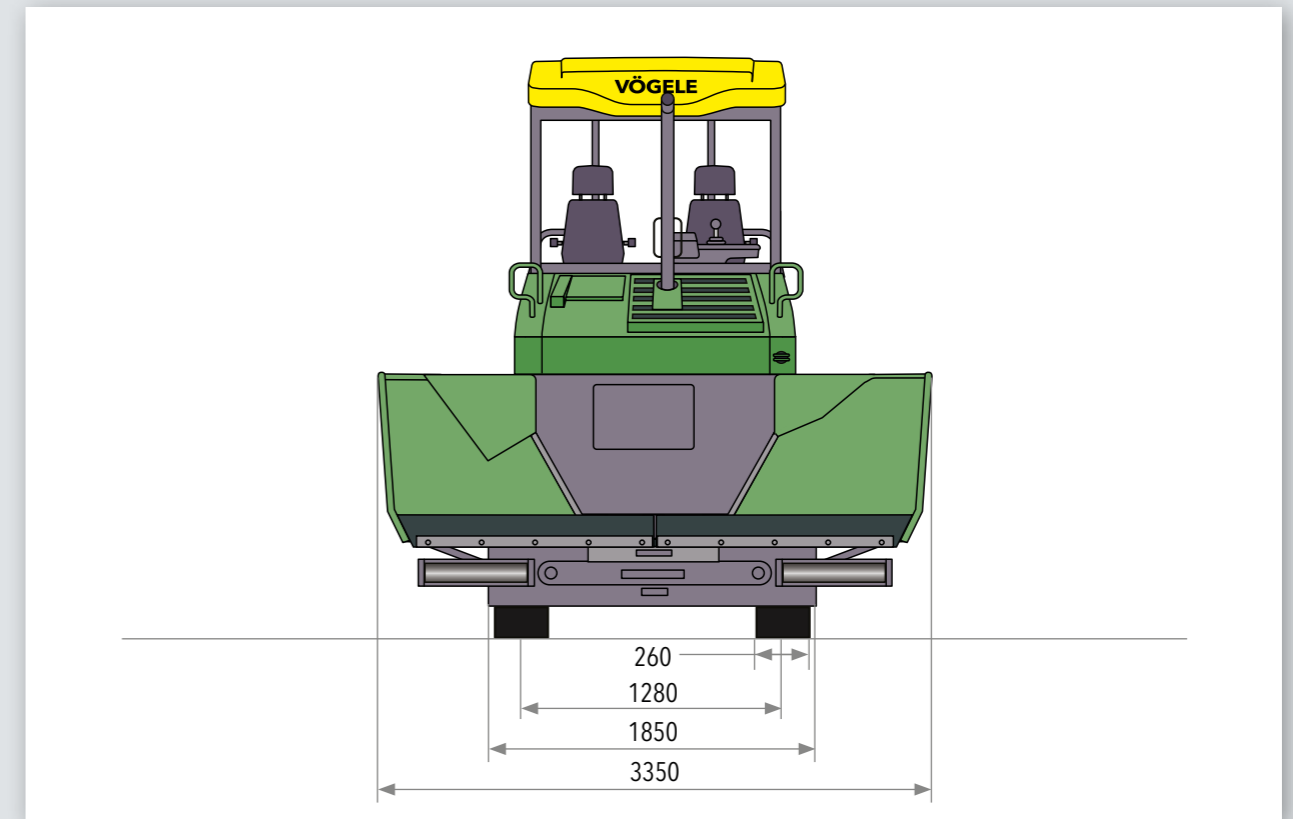
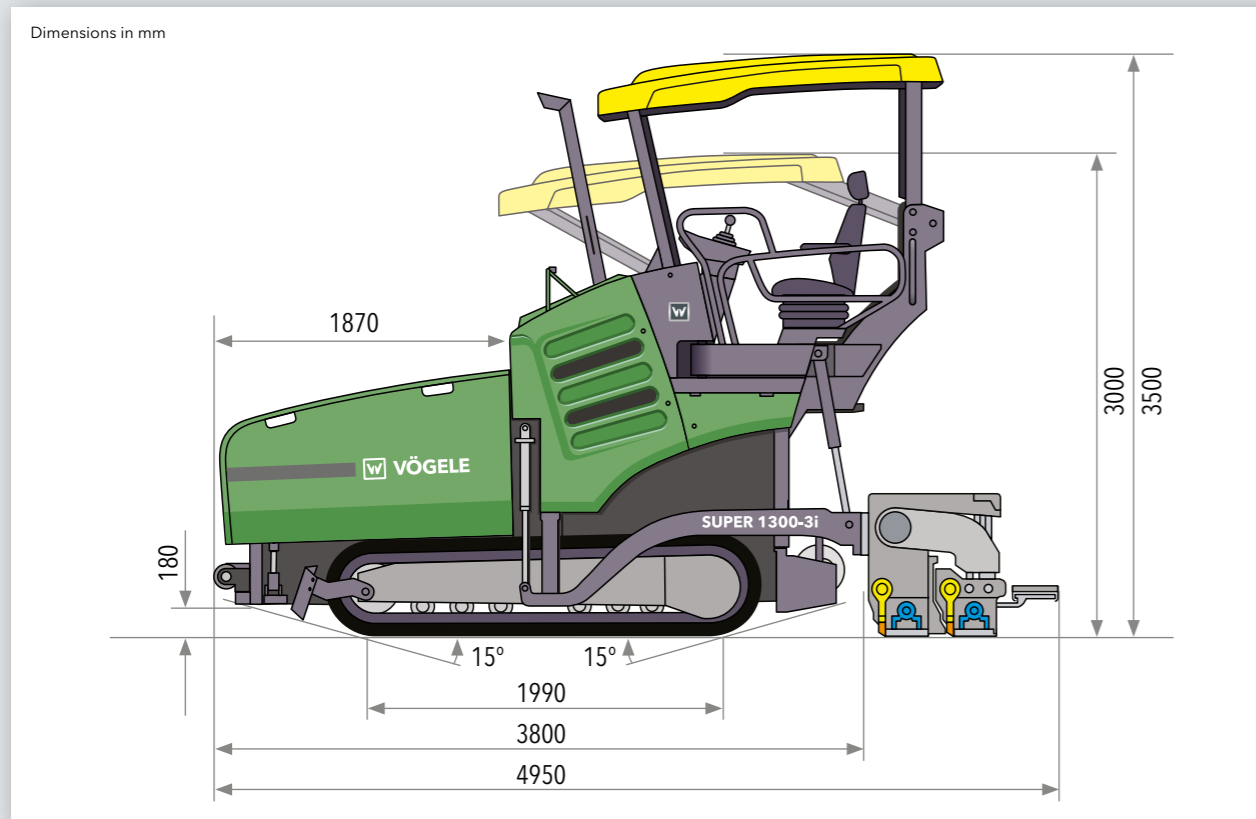

Power unit	
Engine	4-cylinder diesel engine
Manufacturer	Deutz
Type	TCD 3.6L4
Output	
Nominal	80kW at 2,000rpm (according to DIN)
ECO mode	72kW at 1,600rpm
Exhaust emissions standard	
Exhaust gas after-treatment	EU Stage 3b, US EPA Tier 4i DOC
Emission data	
Sound power level	≤105 dB(A) (2000/14/EC and DIN EN 500-6)
Daily noise exposure level	>80 dB(A) (DIN EN 500-6)
Fuel tank	
	110 litres

Undercarriage	
Crawler tracks	provided with rubber pads
Ground contact	1,990mm x 260mm
Track tension adjuster	spring assembly
Track roller lubrication	lifetime
Traction drive	separate hydraulic drive and electronic control provided for each crawler track
Speeds	
Paving	up to 30m/min., infinitely variable
Travel	up to 4.5km/h, infinitely variable

Material hopper	
Hopper capacity	10t
Width	3,350mm
Feed height	580mm (bottom of material hopper)
Push-rollers	oscillating
Position	can be displaced forwards by 80mm

Conveyors and augers	
Conveyors	2, with replaceable feeder bars, conveyor movement reversible for a short time
Drive	separate hydraulic drive provided for each conveyor
Speed	up to 29m/min., infinitely variable (manual or automatic)
Lubrication	maintenance-free
Augers	2, with replaceable auger blades, auger rotation reversible
Diameter	300mm
Drive	separate hydraulic drive provided for each auger
Speed	up to 85rpm, infinitely variable (manual or automatic)
Auger height	
Standard	infinitely variable by 13cm, mechanical
Option	infinitely variable by 13cm, hydraulic

Screed		
AB 340	basic width	1.8m
	infinitely variable range	1.8m to 3.4m
	maximum width	5m
	minimum width	0.75m
	reduction in width: by cut-off shoes	2 x 52.5cm
Screed version	TV	
Layer thickness	up to 25cm	
Screed heating	electric by heating rods	
Power supply	three-phase A.C. generator	

Dimensions (transport) and weights		
Length	tractor unit with screed	
AB 340 TV	4.95m	
Weights	tractor unit with screed	
AB 340 TV	pave widths up to 3.4m	10.6t
	pave widths up to 5m	11.5t

Key: DOC = Diesel Oxidation Catalyst AB = Extending Screed TV = with tamper and vibrators

Subject to technical modification.



Your VÖGELE QR Code will take you directly to the "SUPER 1300-3i" on our website.



**JOSEPH VÖGELE AG**

Joseph-Vögele-Str. 1  
67075 Ludwigshafen · Germany  
marketing@voegele.info

Telephone: +49 (0)621 8105 0  
Fax: +49 (0)621 8105 461  
www.voegele.info



® ERGOPLUS, InLine Pave, NAVITRONIC, NAVITRONIC Basic, NAVITRONIC Plus, NIVELTRONIC, NIVELTRONIC Plus, RoadScan, SprayJet, VÖGELE, VÖGELE PowerFeeder, PaveDock, PaveDock Assistant, AutoSet, AutoSet Plus, AutoSet Basic, ErgoBasic and VÖGELE-EcoPlus are registered Community Trademarks of JOSEPH VÖGELE AG, Ludwigshafen/Rhein, Germany. PCC is a registered German Trademark of JOSEPH VÖGELE AG, Ludwigshafen/Rhein, Germany. ERGOPLUS, NAVITRONIC Plus, NAVITRONIC BASIC, NIVELTRONIC Plus, SprayJet, VISION, VÖGELE, VÖGELE PowerFeeder, PaveDock, PaveDock Assistant, AutoSet, AutoSet Plus, AutoSet Basic and VÖGELE-EcoPlus are trademarks registered in the US Patent and Trademark Office to JOSEPH VÖGELE AG, Ludwigshafen/Rhein, Germany. Legally binding claims cannot be derived from written information or pictures contained in this brochure. Pictures may include optional extras. We reserve the right to make technical or design alterations.