

Mini Class

SUPER 700-3i

TRACKED PAVER



Pave widths 0.5 – 3.2m
Maximum laydown rate 250t/h
Clearance width 1.4m



Great things come in small packages



The machine design of the SUPER 700-3i allows a wide range of applications on the most diverse job sites.

The SUPER 700-3i with the AB 220 Extending Screed in the V version is ideal for small to medium paving jobs such as backfilling trenches or surfacing footpaths or cycle paths. Landscaping contracts, too, are handled perfectly by this Mini Class paver. Last but not least, the small paver is the right choice when it comes to machine-based paving work inside factory halls or basement garages, which makes high demands on paver technology as it requires a compact design and excellent manoeuvrability.

Equipped with the new ErgoBasic operating concept, the SUPER 700-3i can be handled easily and intuitively.

The small paver standing out through an excellent price / performance ratio is the ideal machine in the equipment pools of both private and municipal road building contractors.

The highlights of the SUPER 700-3i



Wide range of paving applications from 0.5 – 3.2m for a large number of paving projects

The ideal option for highly confined job sites thanks to its compact dimensions

Several feed options with the asymmetrical material hopper

Simple operation with the innovative and easy-to-grasp ErgoBasic operating concept

Powerful and cost-efficient thanks to the 55.4kW Deutz diesel engine and ECO mode

Positive tracking and precise steering due to traction drives in closed loops

AB 220 Extending Screed in V version (vibrators)

Compact, light and manoeuvrable

When the job site is particularly narrow, short or low, that's when the SUPER 700-3i comes into its own. Its dimensions make it the ideal candidate for landscaping applications as well as for surfacing car parks, farm tracks, cycle paths or footpaths.

The Mini Class paver is also a popular choice for building motorway central reservations or working in underground car parks, low halls, etc. In all these situations, its small dimensions, great manoeuvrability and high power are the decisive factor for efficiency.

This highly evolved paver is perfectly equipped to handle even the most difficult conditions. The asymmetrical material hopper, for instance, allows the Mini Class paver to be easily fed with mix in extremely confined spaces.



PAVEMENT REHABILITATION ON SMALL MUNICIPAL ROADS



SURFACING CYCLE PATHS OR FOOTPATHS



SURFACING PATHS IN PUBLIC PARKS



INDOOR APPLICATIONS (FACTORY HALLS ETC.)



PAVING ASPHALT BETWEEN TRAMWAY TRACKS



BACKFILLING TRENCHES



PAVING WORK IN SPORTS FACILITIES



SURFACING MEDIAN STRIPS ON MOTORWAYS



PAVING ASPHALT ON DAMS



BUILDING THE BASE FOR PAVING SETTS

The applications illustrated here are typical for the VÖGELE Mini Class. The illustrations may also show the predecessor model.

Slim profiles – Ideal for paving and transport



Paving up to within 5cm of boundaries

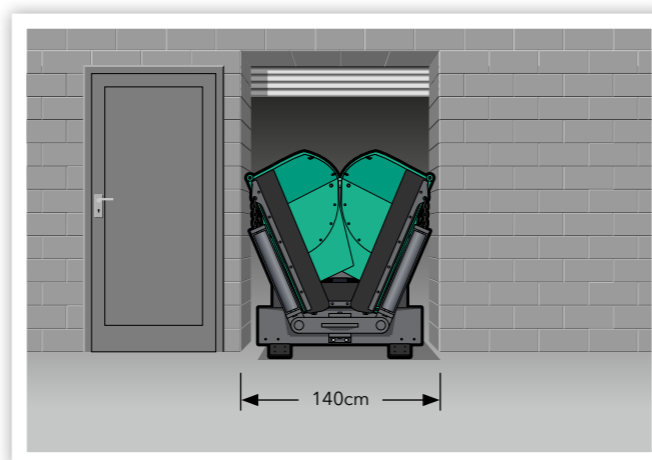
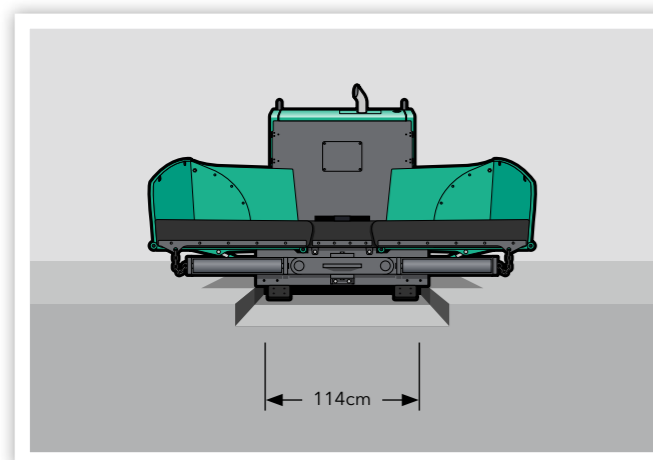

» **With an outer track gauge** of just 1.14m, the paver is ideal for paving between tramway rails and in milled strips.

» **The small clearance width** of 1.4m means that even narrow entrances or gates are no longer an obstacle. The paver can pass through tight entrances and is capable of surfacing traffic areas in buildings such as underground car parks without any problem.

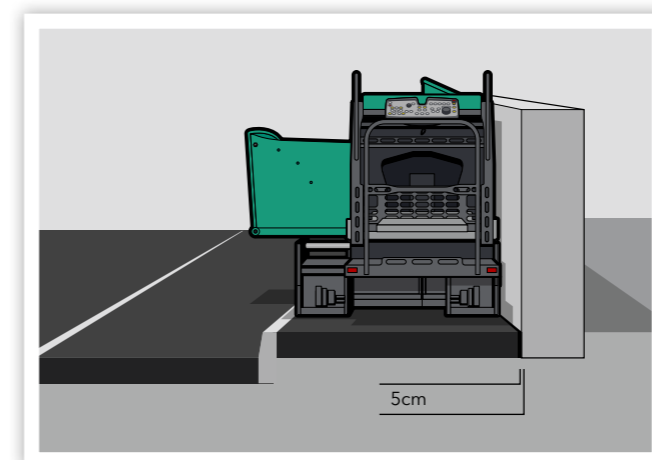

» **The well-thought-out paver design** allows machine-based paving up to within 5cm of boundaries.

» **The overall height** of less than 2m allows paving in low spaces and under canopy roofs.

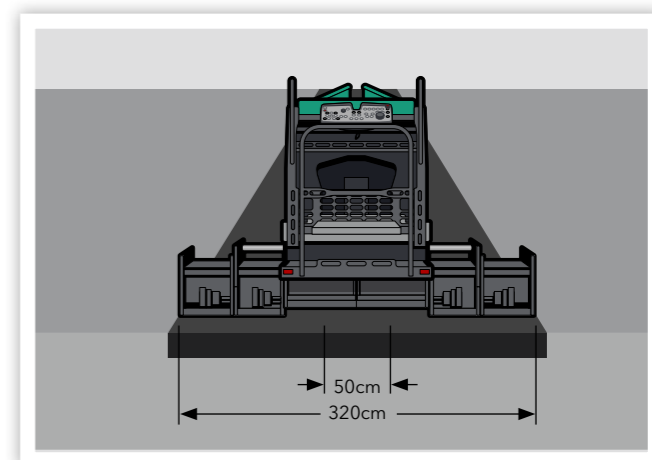

» **The great range of pave widths** – from 0.5 to 3.2m – means it can be used in a wide variety of applications, ensuring high utilization of the machine.

Perfect material management



Several feeding options are particularly important when space is narrow and confined. That is exactly what the large material hopper of the SUPER 700-3i was designed for. It can be conveniently supplied with material by lorry or wheeled loader, depending on how much space is available.

The powerful conveyor, the large conveyor tunnel and the augers adjustable in height ensure that material flows to the screed precisely and in exactly the right quantity.

Several feeding options

The large material hopper with separately folding sides is designed so that the machine can always be supplied with paving material in the best, most cost-effective way. Whether the mix is supplied from the front by lorry or from the side by a wheeled loader, the hopper sides can always be positioned as required.

The optional asymmetrical hopper (left side) allows the paver to be supplied with material by lorry even if the feed vehicle is unable to dock centrally in front of the machine, as is the case when paving along walls or other boundaries, for instance.

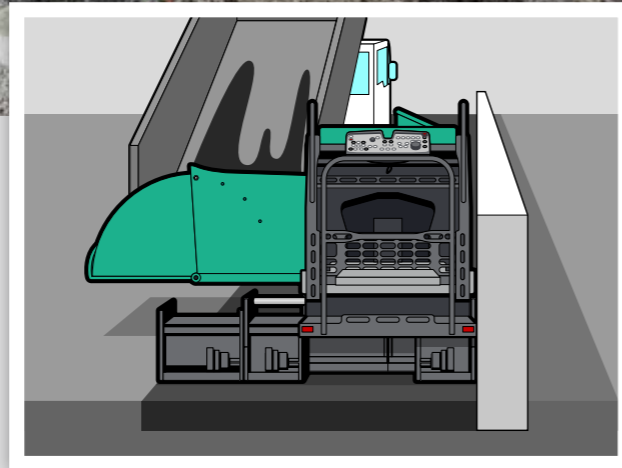

On the asymmetrical material hopper, the left side can be fully folded down hydraulically. Combined with the possibility of adjusting the push-rollers to the left, this makes it easier for material to be supplied by lorry when paving along walls or other boundaries.

Optimal flow of mix

The pavers of the Mini Class come with a powerful material handling system. The large material hopper holds an ample supply of mix, while the wide conveyor tunnel permits a high material throughput.

The large auger blades ensure that the material is spread evenly in front of the screed.



Large material hopper

With a capacity of 5.8t, the material hopper of the small paver is configured to guarantee a controlled supply of mix, preventing any bottlenecks from occurring.

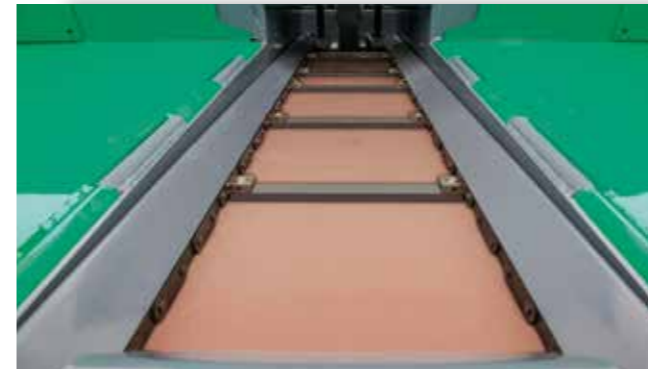

Optimum conveyor drive

The arrangement of the conveyor drive at the rear of the machine makes for optimum power transmission, ensuring a high conveying capacity while minimizing wear of paver components. The conveyor is reversible, preventing any spills of material when repositioning the paver on the job site.



Wide conveyor tunnel

The conveyor tunnel is wide enough to guarantee a high material throughput of up to 250t/h.

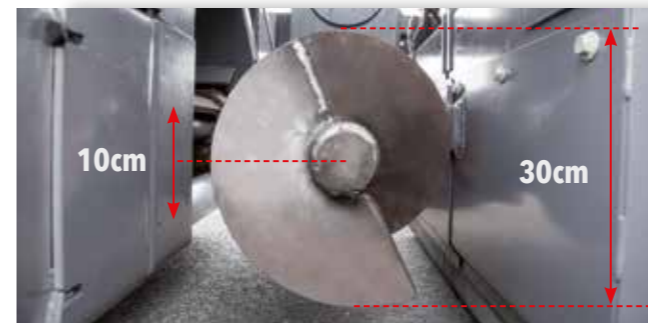

Large auger blades

With a diameter of 300mm, the large auger blades ensure that the material is spread homogeneously. The height of the augers is infinitely variable by 100mm, even hydraulically on request.

The ErgoBasic operating concept



The **ErgoBasic operating concept** was developed on the basis of the proven ErgoPlus operating system which is installed in VÖGELE's large pavers, but it was tailored specifically to the needs and requirements of the users of our Mini Class pavers.

The aim was to develop an operating system for the small machines that is just as quick, precise and intuitive to operate as the system for the large machines.

That makes VÖGELE the only manufacturer to offer a standardized operating concept for all paver classes.



The paver operator's **ErgoBasic** console



“Full control for the machine operator”

The paver operator's ErgoBasic console

Everything at a glance: the functions are arranged in a clear, logical and practical layout that has clearly been inspired by the ErgoPlus operating console.

Given the limited number of functions, there is no need for a display. The status of all settings is indicated as a percentage on LED strips immediately next to the relevant functions.

The type of controls and the symbols used are all in line with those of an ErgoPlus console but have been tailored to the functions of a mini paver.

Other LEDs show the set speed of the augers and the compacting system as well as the fill level of the diesel tank.



Function and status indicators

The function and status indicators mean that the operator always has full control over his machine, even without a display. He can, for instance, read the fill level of the fuel tank directly and identify whether there are any functional faults.

Choice of operating modes for the paver

All the main paving and machine functions can be controlled directly by individual push-buttons on the paver operator's ErgoBasic console. The paver changes between operating modes at the push of a button in the following order: "Pave", "Positioning", "Job Site" and "Neutral". A LED indicates which mode is selected. On leaving "Pave" mode, the memory function stores all the last settings, which means that the paving parameters last used are retrieved immediately after repositioning the machine on the job site, for instance.

Speed of the augers

In automatic mode, the maximum speed of the augers can be adapted to the pave width separately for the left and right using the plus and minus keys. The set value is displayed as a percentage on the LED strip.

Safe operation during the night

Glarefree backlighting comes on automatically as darkness sets in so that the paver operator can also work safely on night-time jobs.

Choice of engine speed ranges

There are three speed ranges for the diesel engine: MIN, ECO and MAX. The desired range can be set easily using the arrow keys. Many construction projects can be completed at ECO rpm. The lower engine speed reduces noise emissions considerably and saves on fuel.

Compacting effort

The speed of the compacting system can be set directly on the paver operator's console. The LED strip from 0 to 100% indicates the set speed for the vibrators. If necessary, the compaction performance can be adjusted quickly and easily via the plus and minus buttons.

Steering with preselected steering angle

The machine is steered by means of a rotary controller which enables the paver operator to manoeuvre the machine precisely even in the tightest spots. For long curves with a constant radius, the desired steering angle can be preselected using arrow keys. The paver stays automatically on the set track until the function is deactivated, allowing the paver operator to monitor the paving process undisturbed.

The **ErgoBasic** remote control unit for the screed

The **safe and easy handling** of all screed functions is a key factor in high-quality pavement construction. That's why a remote control unit for the screed was developed specifically for the ErgoBasic operating system of the new SUPER 700-3i.

The remote control's keypad is laid out logically according to the functional processes. Designed for robustness, it is well able to withstand tough job site conditions.

Operation is easy to understand and can be learned intuitively in a very short space of time, not least because the symbols used in the proven ErgoPlus operating system are found here, too.

The ErgoBasic remote control unit for the screed allows all paving-related functions to be set quickly and easily. That includes direct access to the material handling systems and the sonic sensor for the auger.

There is a remote control unit for each side of the screed. The operator has a large range of actions thanks to the magnetic bracket and spiral cable connection. This means that he can always operate the screed from the best possible position, a factor of immense importance particularly when working in confined spaces.

All the main paving functions can be controlled via the two handy screed remote control units. Simple, language-neutral symbols allow the machine to be operated intuitively.



- 1 // **Conveyor**, automatic / manual
- 2 // **Horn**
- 3 // **Auger**, automatic / manual / reverse
- 4 // **Screed floating** on / off
- 5 // **Screed width control**, one side
- 6 // **Adjustment of screed tow point ram**



Remote control unit for Niveltronic Basic

In line with the ErgoBasic operating concept for Mini Class pavers, VÖGELE has also developed a System for Automated Grade and Slope Control, the Niveltronic Basic. It is completely integrated into the machine control system and therefore perfectly adapted to the paver model concerned. Another outstanding aspect of Niveltronic Basic is its particularly simple and intuitive handling, a feature which makes it easy even for less experienced operators to learn their way around the system. This creates ideal conditions for the small paver to work true to line and level on any base.

Each side of the screed is operated by a separate compact and exceedingly robust Niveltronic Basic remote control unit. These units are easily removed from their magnetic brackets, giving the operator a large range of action so that he can always take up the optimum position for every paving job.

A variety of sensor types is available for Niveltronic Basic, in keeping with the machine's large and varied range of uses. It extends from mechanical sensors to non-contacting sonic sensors and even includes a laser receiver for work on larger sites.

The System for Automated Grade and Slope Control can simultaneously be connected to two grade sensors and a slope sensor. The type of sensor used is detected automatically. The kind of reference – ground, tensioned wire or transverse slope – can be easily set on the remote control unit.

The remote control units come with all the functions required for high-precision grade and slope control. Clear symbols allow the machine to be operated intuitively.

- 1 // Deviation** from specified values
- 2 // Niveltronic Basic** on / off
- 3 // Setting:** Sensor sensitivity
- 4 // Selecting:** Kind of reference (ground, tensioned wire, transverse slope)
- 5 // Quick set-up**
- 6 // Setting:** Specified value
- 7 // Sensor calibration**



Future-proof drive technology

Three main components define the power unit of a SUPER 700-3i: its modern, liquid-cooled diesel engine, a splitter gearbox flanged directly to the engine and a large cooler assembly.

The driving force in this power pack from VÖGELE is its Deutz diesel engine of type TCD 2.9 L4. This four-cylinder engine delivers 55.4kW at 2,200rpm. Yet the fuel-saving ECO mode is sufficient for many applications. And even then, the SUPER 700-3i still has a full 54kW at its disposal. Moreover, the machine generates even less noise when running at just 1,800rpm.

A large cooler assembly ensures that the power unit always delivers its full output. With innovative air routing and a variable-speed fan, temperatures

are continually maintained within the optimum range, significantly extending the service life of both the diesel engine and the hydraulic oil. A further advantage is that the machine can operate without difficulty in all climate regions worldwide.

All hydraulic consumers are directly supplied with hydraulic oil via the splitter gearbox. Hydraulic pumps and valves are centrally located, making them optimally accessible for servicing. Even the powerful generator for screed heating is flanged directly onto the splitter gearbox; its integrated oil cooling system makes it completely maintenance-free and very quiet.

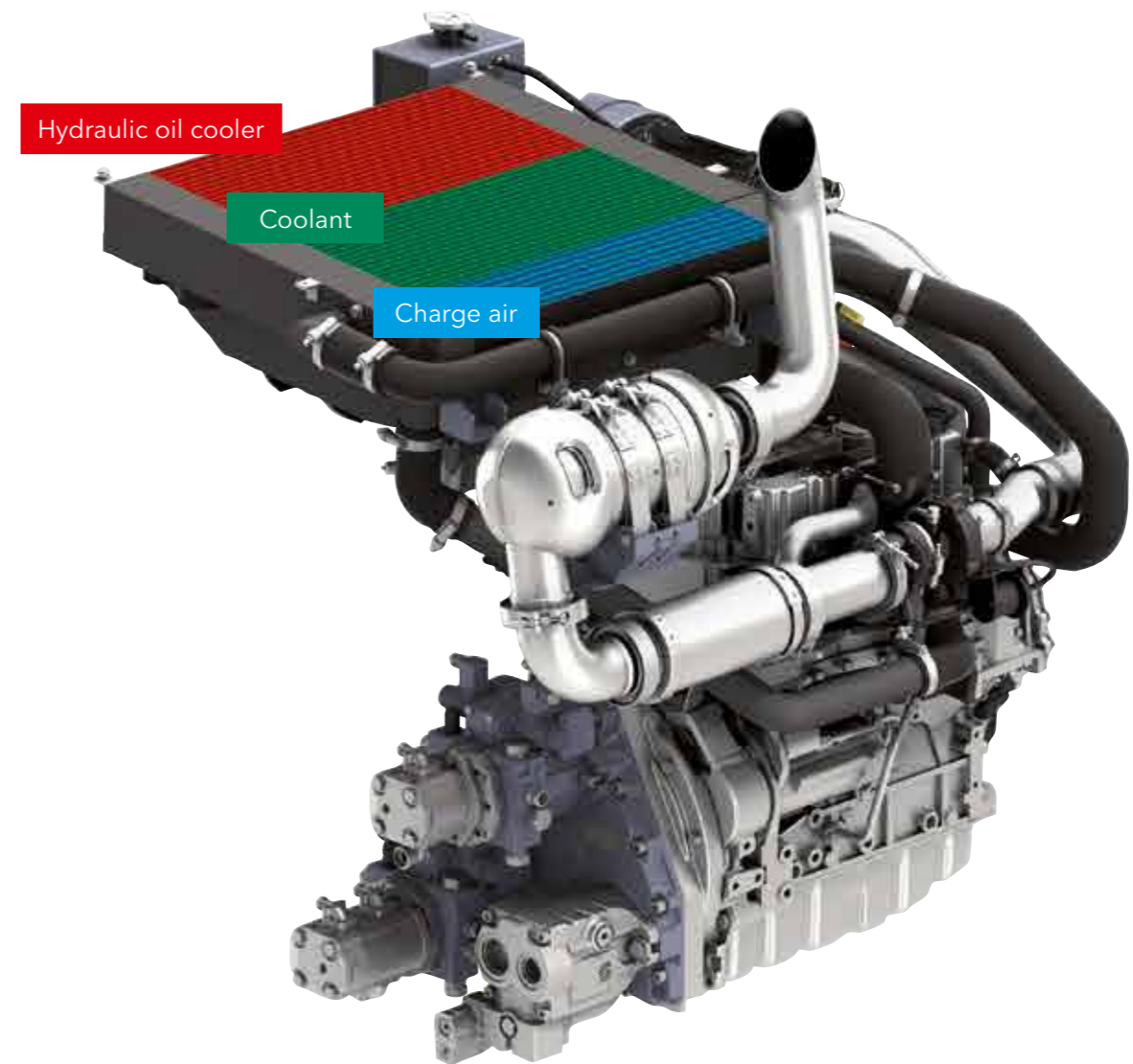

A large cooler assembly with innovative air routing is installed for perfect cooling of the engine coolant, hydraulic oil and charge air in all climatic zones the world over. This ensures that the engine can deliver maximum output and helps prolong its service life.

» **Machines with the suffix "i"** in their product designation are not only economical, but also extremely clean.

The "i" stands for "intelligent emission control" and is found in the type names of all machines from the WIRTGEN GROUP equipped with the latest engine technology. Thanks to sophisticated exhaust gas after-treatment, this engine complies with the strict requirements of European emissions standard Stage 4 as well as US EPA standard Tier 4f.

» **Delivering 55.4kW**, the modern Deutz diesel engine can achieve optimum efficiency.

» **ECO mode with 54kW** cuts operating costs and allows super-quiet operation.

» **The splitter gearbox** optimally transmits the power output of the diesel engine to the hydraulic pumps.

Precision on tracks



Positive tracking when moving straight and accurate cornering due to separate drive and electronic control provided for each crawler track.



» **Thanks to powerful separate drives** fitted into the sprockets of the crawler tracks, engine output is translated into pave speed with no loss of power.

» **The long crawler tracks** deliver maximum traction thanks to their large footprint. This ensures a constant forward speed even when operating in difficult terrain.

Identical service concept



The standardized service concept conceived for the VÖGELE pavers means that servicing is quick and uncomplicated. Large hinged panels provide convenient access to all service points on the machine.



Wear-resistant components also guarantee a long service life.



All hydraulic pumps are located on the splitter gearbox and provide maximum service-friendliness thanks to their clear arrangement and easy accessibility.



AB 220 V Extending Screed

The new AB 220 Extending Screed in the V version is specially designed for use with the SUPER 700-3i. It comes with a basic width of 1.2m and extends hydraulically up to 2.2m.

The addition of bolt-on extensions increases the pave width of the AB 200 V to a maximum of 3.2m.

For pave widths smaller than the paver's basic width of 1.2m, a special system for pave width reduction has been developed allowing infinite variation in width between 1.2m and 0.5m.

The AB 220 V is equipped with eccentric vibrators in both the basic screed and the extending units. This provides for a perfect pavement surface and uniform compaction across the full pave width.

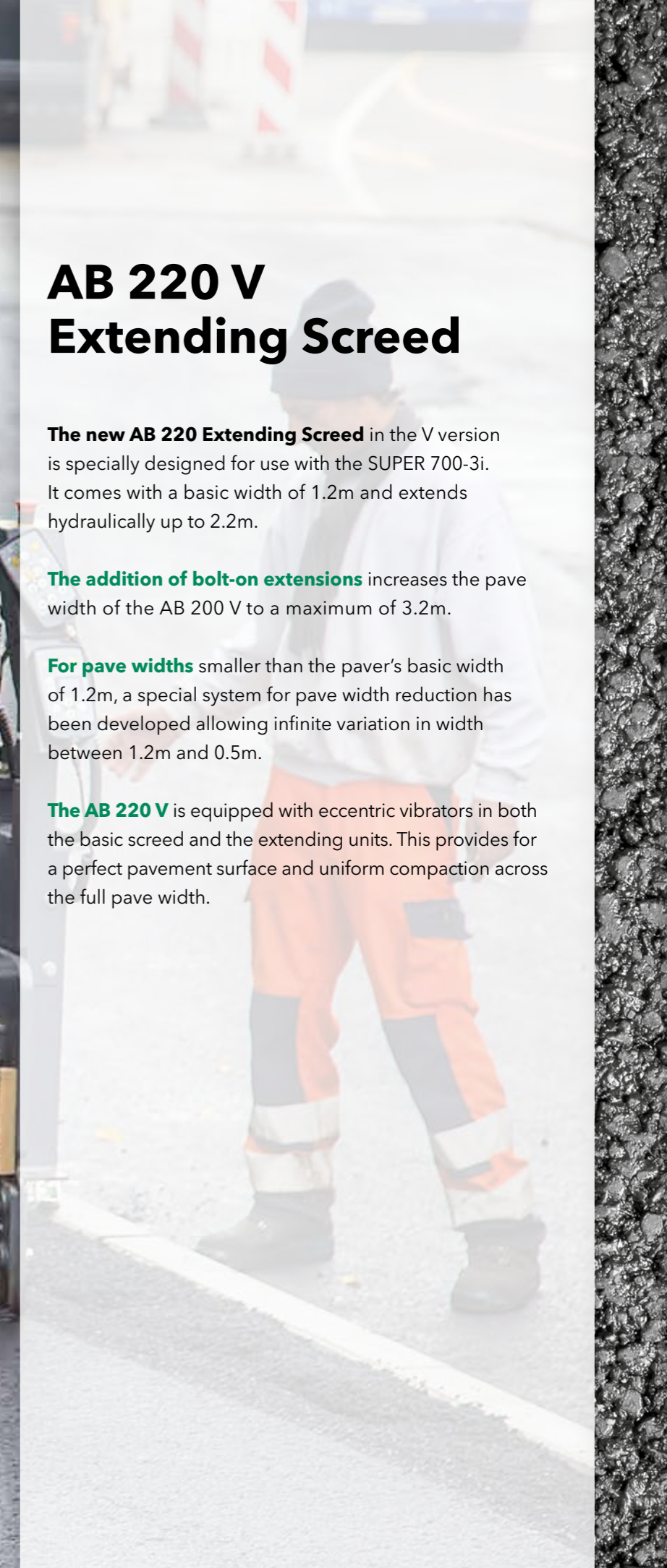

The screed for the SUPER 700-3i

AB 220 V

Pave widths

- » Infinitely variable range from 1.2m to 2.2m.
- » Maximum pave width through bolt-on extensions:
 - » 2.7m (2 x 25cm).
 - » 3.2m (2 x 50cm).
- » Minimum pave width of 0.5m with a system for pave width reduction.

Compacting system

- » AB 220 V with vibrators



AB 220 V without bolt-on extensions

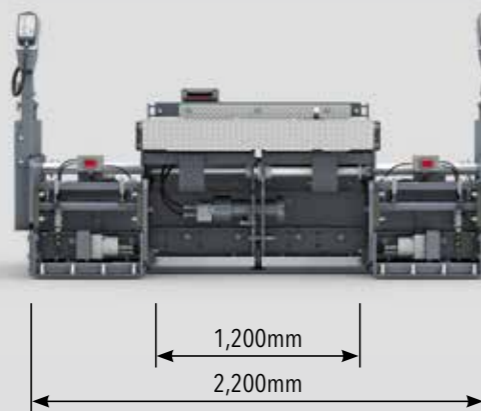

AB 220 V with 50cm bolt-on extensions

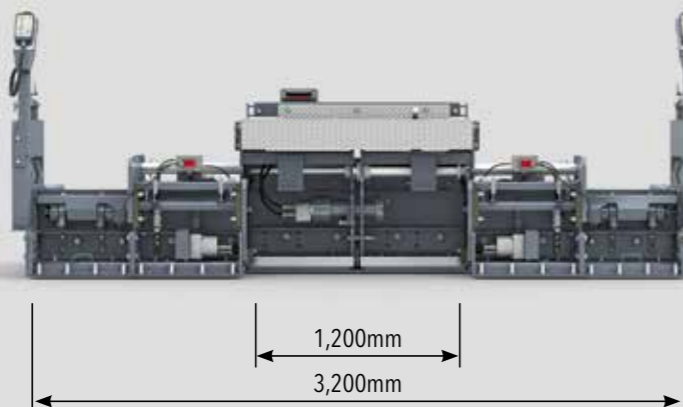

Reduction in width

» **Once mounted**, the system for pave width reduction allows infinite variation of the pave width from 1.2m to 0.5m. This is conveniently handled from the paver operator's stand without a need for conversion.

» **Thanks to the system for pave width reduction** offered by VÖGELE, the backfilling of trenches or paving in an asymmetrical width along kerbstones or walls is an easy game, even when using joint tape.



With the system for pave width reduction fitted, the screed floats on the mix just as it does when paving in a non-reduced width. This allows the layer thickness to be adjusted via the screed tow point rams or even to be controlled with Niveltronic Basic.

The floating screed not only provides for precise paving results, but also achieves excellent pre-compaction.



All the facts at a glance

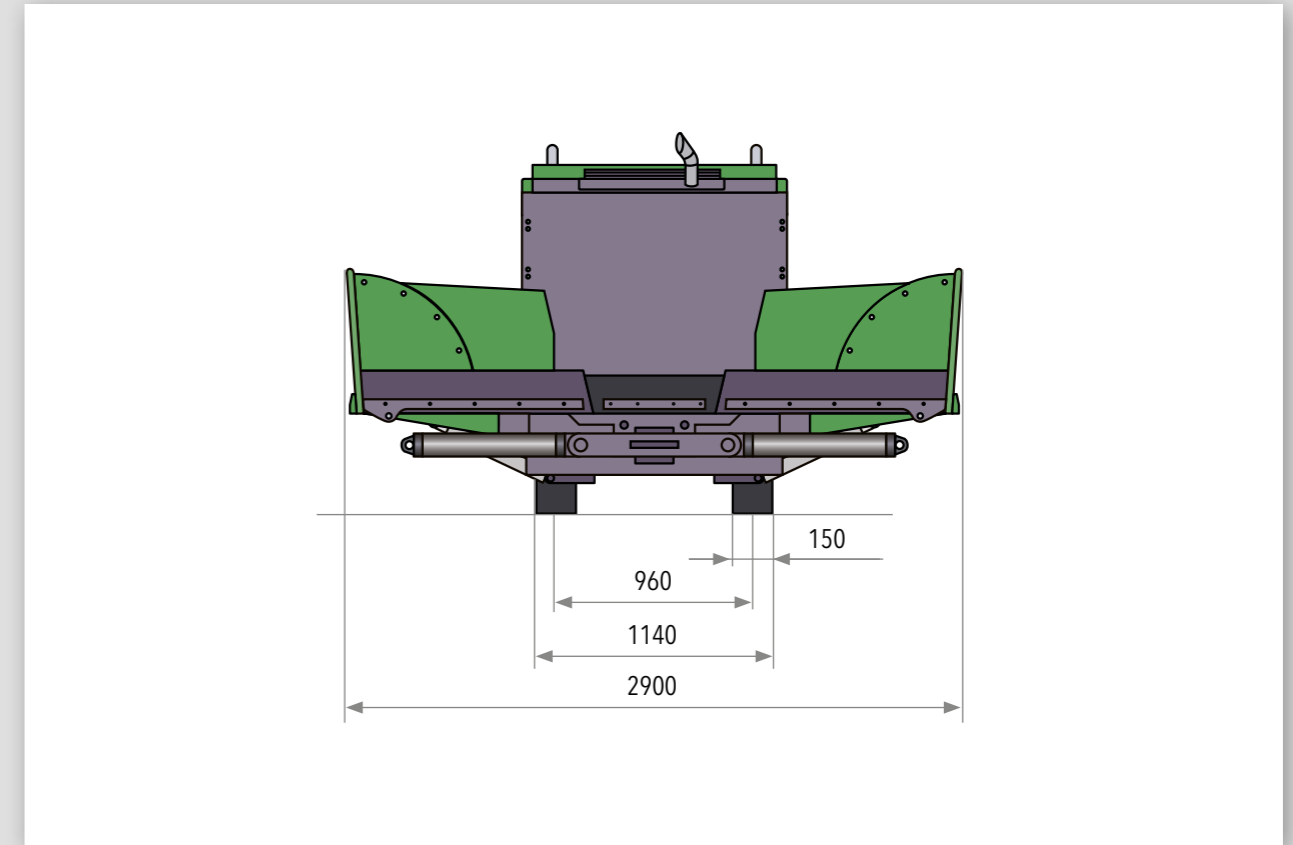
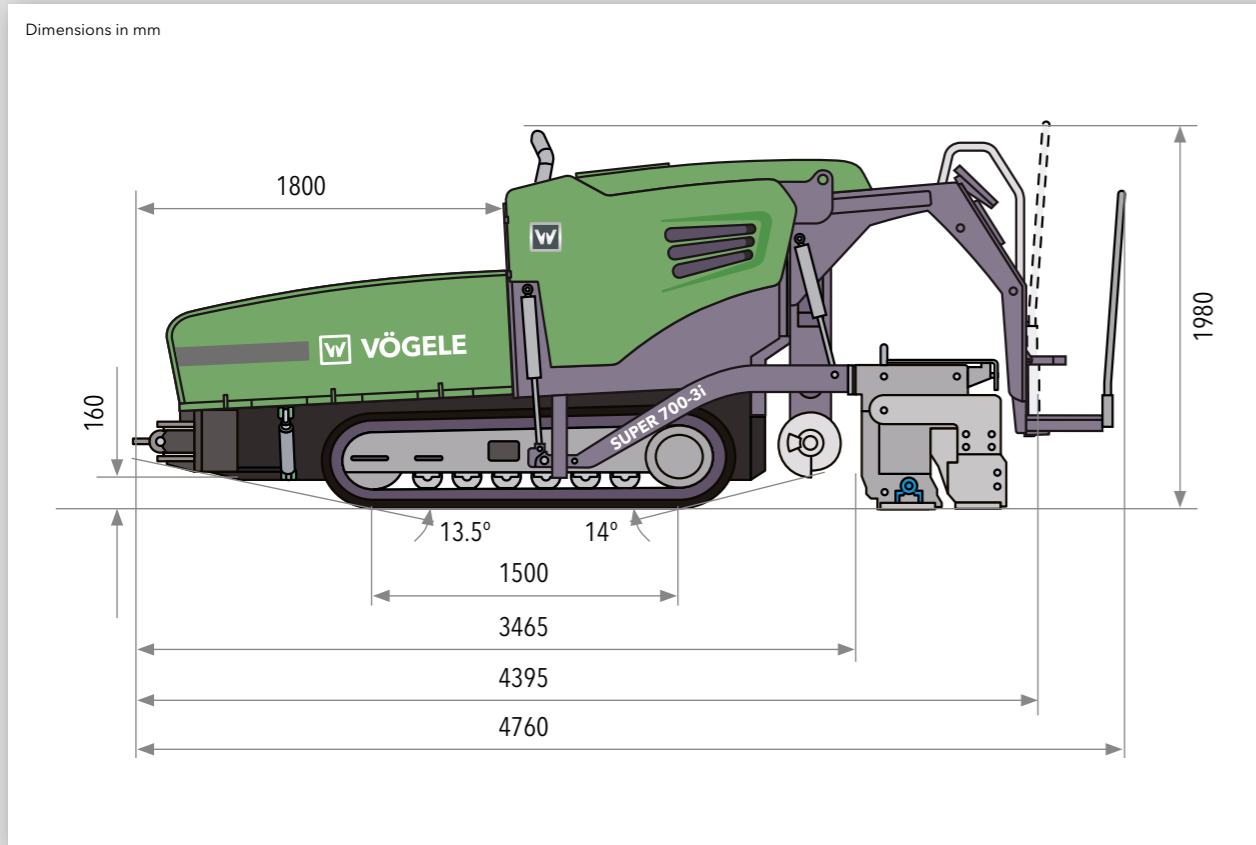

| Power unit | |
|-----------------------------|--|
| Engine | 4-cylinder diesel engine, liquid-cooled |
| Manufacturer | Deutz |
| Type | TCD 2.9 L4 |
| Output | |
| Nominal | 55.4kW at 2,200rpm (according to DIN) |
| ECO mode | 54kW at 1,800rpm |
| Exhaust | |
| emissions standard | EU Stage 4, US EPA Tier 4f |
| Exhaust gas after-treatment | DOC |
| Emission data | |
| Sound power level | ≤104 dB(A) (2000/14/EC and DIN EN 500-6) |
| Daily noise exposure level | >80 dB(A) (DIN EN 500-6) |
| Fuel tank | 80 litres |

| Undercarriage | |
|--------------------------|--|
| Crawler tracks | provided with rubber pads |
| Ground contact | 1,500mm x 180mm |
| Suspension | rigid |
| Track tension adjuster | spring assembly |
| Track roller lubrication | lifetime |
| Traction drive | separate hydraulic drive and electronic control provided for each crawler track |
| Speeds | |
| Paving | up to 30m/min., infinitely variable |
| Travel | up to 3.6km/h, infinitely variable |
| Service brake | hydraulic |
| Parking brake | spring-loaded multiple-disc brake, maintenance-free |
| Material hopper | |
| Hopper capacity | 5.8t |
| Width | 2,900mm |
| Feed height | 500mm (bottom of material hopper) |
| Push-rollers | oscillating, fold up with the sides of the material hopper, adjustable by 100mm to the front, 50cm to the left |

| Conveyor and augers | |
|---------------------|--|
| Conveyor | 1, with replaceable feeder bars, conveyor movement is reversible |
| Drive | hydraulic |
| Speed | up to 20m/min., infinitely variable (manual or automatic) |
| Augers | 2, mounted overhung, auger rotation is reversible |
| Diameter | 300mm |
| Drive | separate hydraulic drive provided for each auger |
| Height | |
| Standard | infinitely variable by 10cm, mechanical |
| Option | infinitely variable by 10cm, hydraulic |

| Screed | | |
|-----------------------------------|---|--------------|
| AB 220 | basic width | 1.2m |
| | infinitely variable range | 1.2m to 2.2m |
| | maximum width | 3.2m |
| | minimum pave width with system for pave width reduction | 0.5m |
| Screed version | V | |
| Layer thickness | up to 15cm | |
| Screed heating | electric by heating rods | |
| Power supply | three-phase A.C. generator | |
| Dimensions (transport) and weight | | |
| Clearance width | 1.4m | |
| Length | tractor unit and screed | |
| AB 220 V | 4.4m | |
| Weight | tractor unit and screed | |
| AB 220 V | 6.2t | |

Key: DOC = Diesel Oxidation Catalyst AB = Extending Screed V = with vibrators

Subject to technical alterations.



Your VÖGELE QR Code will take you directly to the "SUPER 700-3i" on our website.



JOSEPH VÖGELE AG

Joseph-Vögele-Str. 1
67075 Ludwigshafen · Germany
marketing@voegele.info

Telephone: +49 (0)621 8105 0
Fax: +49 (0)621 8105 461
www.voegele.info



® ERGOPLUS, InLine Pave, NAVITRONIC, NAVITRONIC Basic, NAVITRONIC Plus, NIVELTRONIC, NIVELTRONIC Plus, RoadScan, SprayJet, VÖGELE, VÖGELE PowerFeeder, PaveDock, PaveDock Assistant, AutoSet, AutoSet Plus, AutoSet Basic, ErgoBasic and VÖGELE-EcoPlus are registered Community Trademarks of JOSEPH VÖGELE AG, Ludwigshafen/Rhein, Germany. PCC is a registered German Trademark of JOSEPH VÖGELE AG, Ludwigshafen/Rhein, Germany. ERGOPLUS, NAVITRONIC Plus, NAVITRONIC BASIC, NIVELTRONIC Plus, SprayJet, VISION, VÖGELE, VÖGELE PowerFeeder, PaveDock, PaveDock Assistant, AutoSet, AutoSet Plus, AutoSet Basic and VÖGELE-EcoPlus are trademarks registered in the US Patent and Trademark Office to JOSEPH VÖGELE AG, Ludwigshafen/Rhein, Germany. Legally binding claims cannot be derived from written information or pictures contained in this brochure. Pictures may include optional extras. We reserve the right to make technical or design alterations.