

Leading through passion.

Cold Milling Machines

W 50 R | W 50 Ri | W 60 R | W 60 Ri



At a glance: outstanding features of the new cold milling machines

02
03

Highlights in operation (pages 4 / 5)

1 | INTUITIVE, PRECISE LEVELLING WITH LEVEL PRO PLUS

- > Easy and intuitive operation
- > Many newly added complementary and automated features
- > Fully integrated into the machine management system
- > Milling depth measurement via displacement sensors in the hydraulic cylinders of the side plates

2 | MULTIFUNCTIONAL ARMREST BOOSTS EFFICIENCY

- > Ergonomically designed multifunctional armrest with colour control screen
- > Additional machine height adjustment feature included in armrest
- > Job data are recorded and displayed on the control screen

3 | UNMATCHED VISIBILITY CONCEPT

- > Unobstructed view of the side plates, left and right
- > Optimized view towards the front and of the milling edge
- > Good rear visibility

Highlights in driving and steering (pages 6 / 7)

4 | TIME-SAVING PIVOTING MECHANISM

- > Exceptionally quick, automatic pivoting of the right-hand rear wheel
- > Safe and firm locking in end position
- > Heavy-duty swivel joint via large friction bearing

5 | INNOVATIVE, EFFECTIVE STEERING FEATURES

- > Offset front wheels
- > Particularly wide front wheels
- > Extremely large locking angle of the front wheels
- > New, automatic tracking of the right-hand rear wheel



Highlights in performance and productivity (pages 10/11)

9 | HIGH TRACTION ENSURED BY PERFECT WEIGHT DISTRIBUTION

- > Variable supplementary weights of up to 1,000 kg
- > Extremely low centre of gravity
- > Centrally arranged water and diesel tanks in neutral position
- > High machine stability in both three-wheel and four-wheel design

10 | BEST-IN-CLASS PRODUCTIVITY

- > Tremendous engine power at maximum torque
- > Three different milling drum speed options
- > State-of-the-art engine control to minimize diesel consumption
- > Hydraulically engaging power belt tensioner



Highlights in milling and loading (pages 8/9)

7 | SUPERIOR CUTTING TECHNOLOGY BOOSTS PERFORMANCE

- > Overload sensor at the scraper blade and proactive floating position at the side plates, left and right
- > New, wear-resistant HT08 toolholder system
- > Partial loading possible even at maximum milling depth
- > Extremely small distance of outer machine edge to milling edge

8 | HIGH LOADING CAPACITY FOR MAXIMUM PERFORMANCE

- > Hydraulically operated folding conveyor
- > Wide conveyor slewing angles
- > Quick-release coupling for easy mounting and removal of the discharge conveyor

6 | DYNAMIC AND QUICK MANOEUVRING

- > Travel speed of up to 12 km/h
- > Swift steering using the steering wheel
- > Highly precise steering via the fingertip steering feature integrated in the armrest
- > Reversing with the milling drum switched on

Highlights in operation

04
05

INTUITIVE LEVELLING

The new LEVEL PRO PLUS levelling system offers easy and intuitive operation, guaranteeing high-quality, highly precise milling results.

FULLY INTEGRATED LEVELLING SYSTEM

Full integration of the LEVEL PRO PLUS levelling system into the machine management system allows a high degree of automation.



PERFECT OPERATION PAYS OFF

The ingenious operating, visibility and levelling concept of the W 50 R/ W 50 Ri and W 60 R/W 60 Ri makes you work fast. Yet it not only speeds up processes and improves results: even more importantly, operators derive greater satisfaction from their work. At the end of the day, this translates into greater productivity and profitability – whatever the job.

LEVELLING SENSORS

The reference line is scanned by high-precision displacement sensors in the hydraulic cylinders of the side plates and then displayed on the high-resolution LEVEL PRO PLUS control screen.



Machine height adjustment feature in the multifunctional armrest.

HEIGHT ADJUSTMENT IN INCREMENTS

This new feature integrated in the left-hand control panel enables precise adjustment of the milling depth in increments of 1 mm or 5 mm.

REAR VISIBILITY

The compact conveyor suspension permits good visibility of the milled surface at the rear of the machine.

VIEW OF THE AREA AHEAD OF THE MILLED SURFACE

The geometry of the operator's platform has been optimized to ensure an unobstructed view not only of the right-hand but also of the left-hand side plate.

ADDITIONAL LEVELLING FEATURES

The LEVEL PRO PLUS levelling system offers numerous complementary and automated features such as adjusting the set value automatically when changing the sensor.

FRONT VISIBILITY

The slender design of the machine frame provides an unobstructed view of the milling edge on the right.

JOB DATA

Pertinent job details are provided automatically to allow the visualization of daily performance rates.

MULTIFUNCTIONAL ARMREST

The multifunctional, individually adjustable armrest combines innovative design and perfect user-friendliness. Important information is displayed on the colour control screen.

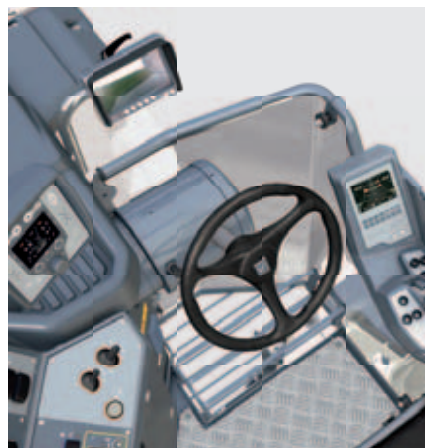

View of the area ahead of the milled surface.



LEVEL PRO PLUS levelling system.

Highlights in driving and steering

06
07

EXTREMELY LARGE LOCKING ANGLE

Extremely large locking angles to the left and right guarantee extremely small turning radii.

SWIFT STEERING

The steering wheel is used for particularly quick steering.

FINGERTIP STEERING

The highly responsive hydraulic steering system enables the machine to be steered quickly and effortlessly also via the right-hand armrest.

REVERSING

Reversing with the milling drum switched on permits fast and easy manoeuvring on the job site.

AUTOMATIC TRACKING FEATURE

Automatic tracking of the right-hand rear wheel when pivoted in front of the drum gives the small milling machine unrivalled manoeuvrability.



MAXIMUM SPEED OF 12 KM/H

Travel speeds of up to 8 km/h (three-wheel design) and 12 km/h (four-wheel design), respectively, ensure the quick completion of construction projects.



THREE OR FOUR WHEELS

Depending on customer specifications, the small milling machine is available in three-wheel or four-wheel design.



WIDE WHEELS

The extra-wide front wheels ensure low area loads at reduced wear and tear.

COLD MILLING MACHINE WITH BEST-IN-CLASS MANOEUVRABILITY AND OPERATING SPEED

Manoeuvrable and fast-working cold milling machines save both time and money. Whether milling extremely small radii, turning in narrow passages, pivoting the right-hand rear wheel, negotiating obstacles or quickly travelling to the next job site on its own: the W 50 R/W 50 Ri and W 60 R/W 60 Ri maximize time savings in any situation.

AUTOMATIC PIVOTING FEATURE

Automatic pivoting of the right-hand rear wheel is performed extremely quickly without having to lower the milling drum to the ground.

SAFE LOCKING

Safe and firm locking of the right-hand rear wheel to the machine frame when in end position minimizes wear and enhances accuracy.

HEAVY-DUTY SWIVEL JOINT

The massive friction bearing minimizes the amount of kinematic play, thus ensuring consistently precise milling results.

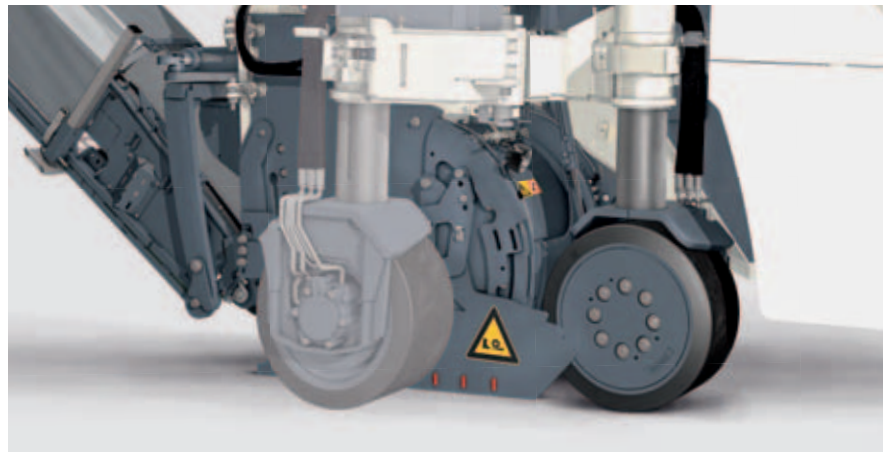

Quick pivoting of the right-hand rear wheel.

OFFSET FRONT WHEELS

The front wheels are offset by 15 cm (in four-wheel design) to travel "in the same track" when the steering wheel is turned to the right. In addition, the machine enables an optimized approach to obstacles and ground edges.



Detailed view of the four-wheel front axle.

Highlights in milling and loading

08
09

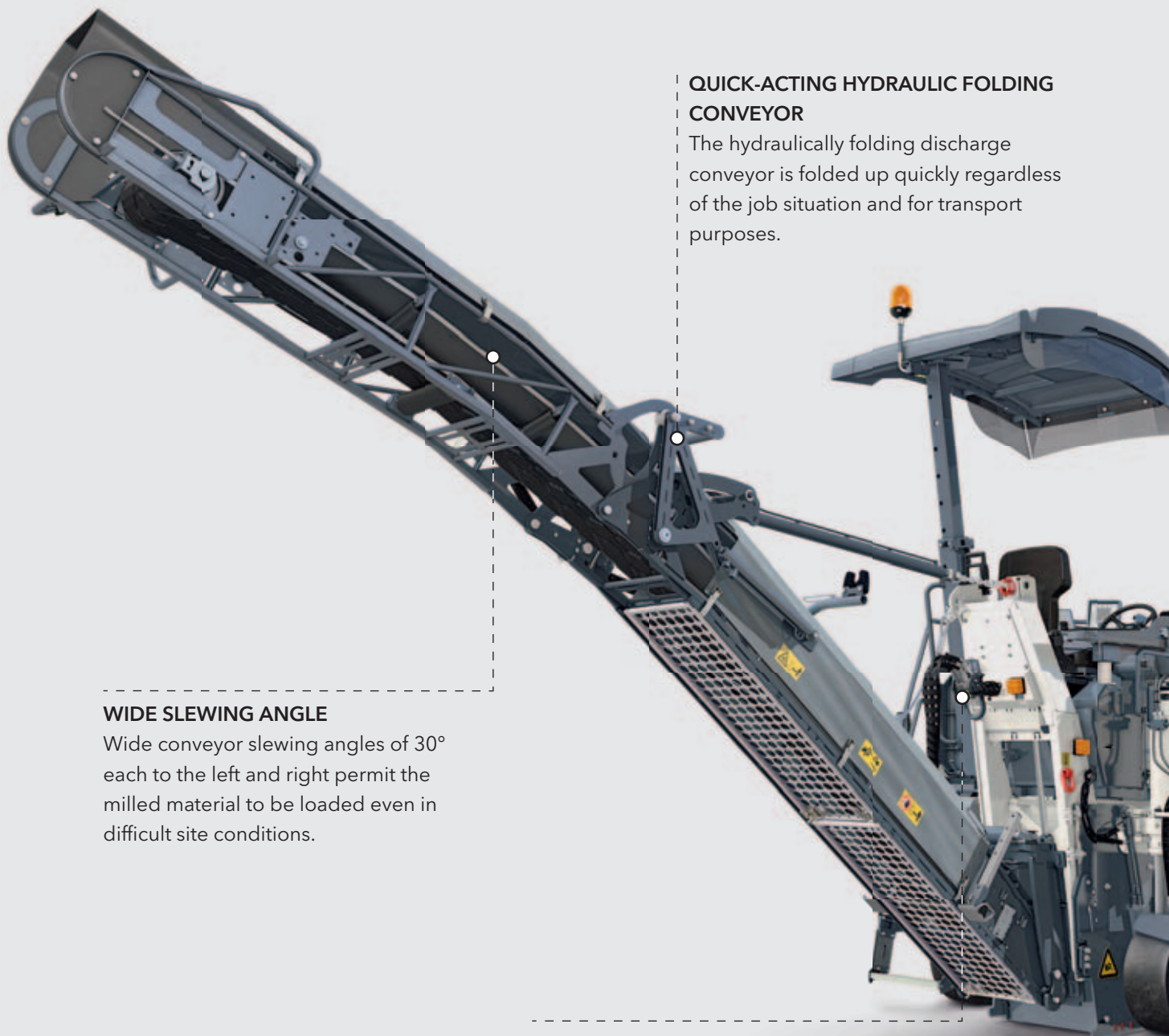

WIDE SLEWING ANGLE

Wide conveyor slewing angles of 30° each to the left and right permit the milled material to be loaded even in difficult site conditions.

QUICK-ACTING HYDRAULIC FOLDING CONVEYOR

The hydraulically folding discharge conveyor is folded up quickly regardless of the job situation and for transport purposes.

QUICK-RELEASE COUPLING

The innovative quick-release coupling ensures easy plugging and unplugging of the hydraulic connections when mounting or removing the discharge conveyor.

VARIOUS MILLING DRUMS

A vast array of original WIRTGEN standard and special milling drums is on offer to cater to a wide range of applications. The distinctive feature of these drums is their WIRTGEN ornamental flange.

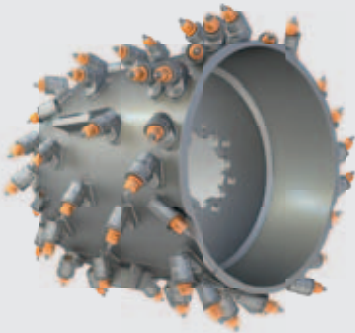

MAXIMUM FUNCTIONALITY

The W 50 R/W 50 Ri and W 60 R/W 60 Ri have been designed for maximum performance when loading the milled material. And the innovative, completely round milling drum unit causes any milling machine operator's heart to miss a beat. Overall, a host of smart solutions developed for the milling drum, side plates, scraper blade and gradation control beam make the milling process faster and easier whilst ensuring higher quality standards.

OVERLOAD SENSORS AND PROACTIVE FLOATING POSITION

These smart, automated features prompt the scraper blade or side plates to be raised briefly, for example, to prevent them from jamming or sinking in on soft ground.

NEW, WEAR-RESISTANT HT08 TOOLHOLDER SYSTEM

The newly developed HT08 toolholder system impresses with high wear resistance and an extended lifespan.

DECOUPLED SCRAPER BLADE

The scraper blade has been decoupled from the loading conveyor, which permits partial loading even when milling at the maximum possible depth.

ALTERNATIVE MILLING WIDTHS

Two machine models are available offering milling widths of 500 mm or 600 mm, respectively.

EXTREMELY SMALL DISTANCE OF OUTER MACHINE EDGE TO MILLING EDGE

The extremely small distance of the right-hand milling edge to the outer edge of the machine ensures that only a minimum amount of residual material remains on the milled surface.



Milling drum unit with intelligent features.

Highlights in performance and productivity

10
11

HIGH ENGINE POWER

The exceedingly powerful, high-torque engine guarantee fast, productive operation even at the maximum milling depth.

ENGINE COOLING

Cooling system with temperature-controlled fan speed for low noise emission levels.

STATE-OF-THE-ART ENGINE CONTROL

The engine speed is adjusted to the specific requirements, which ensures low-noise operation and minimizes diesel consumption.

HIGH MACHINE STABILITY

The new four-wheel axle offers perfect manoeuvrability regardless of site conditions.

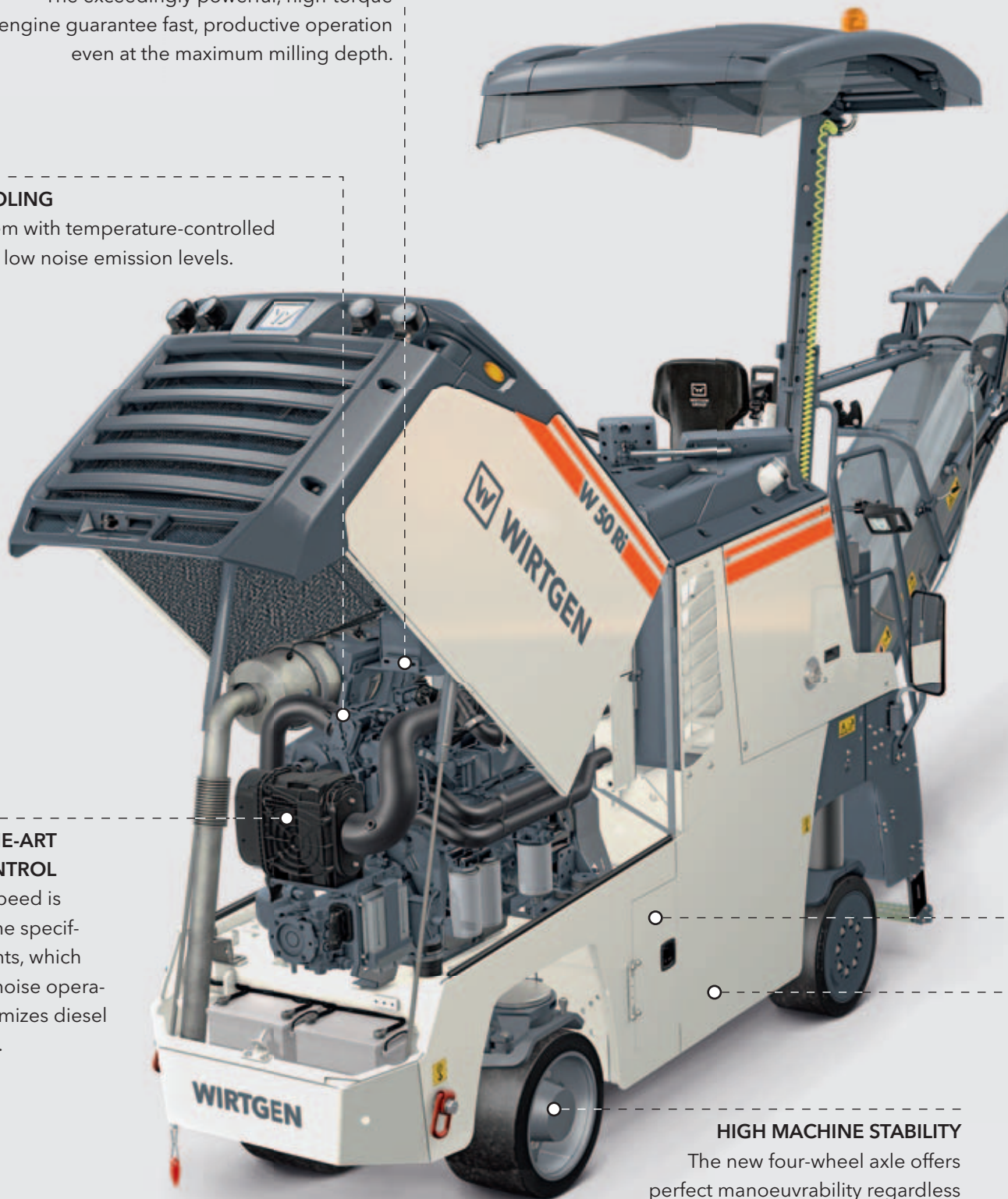

TOP PERFORMANCE IN ANY JOB

Complete your jobs up to 20% faster whilst maximizing cost savings: providing utmost flexibility in application, the W 50 Ri/W 60 Ri is sure to pave the way to success.

DIFFERENT MILLING DRUM SPEEDS

Three different milling drum speeds enable tremendous milling outputs in a wide range of applications.

CENTRALLY ARRANGED TANKS

Water and diesel tanks arranged in the centre of the machine ensure a neutral distribution of the axle load and optimum traction regardless of the tanks' filling levels.

SUPPLEMENTARY WEIGHTS

The low empty weight of the small milling machine and variable supplementary weights of up to 1,000 kg altogether combine to offer a high operating weight, optimum traction and effortless transport.

ANTI-VIBRATION MOUNTED ENGINE STATION

The anti-vibration mounted engine station ensures low vibration and noise levels, thus offering high driving comfort.

HYDRAULIC POWER BELT TENSIONER

The automatically engaging, hydraulically operated power belt tensioner enables efficient and reliable transmission of power.

LOW CENTRE OF GRAVITY

Optimum traction is ensured by the exceptionally low centre of gravity and perfect weight distribution of the machine.



Completing jobs up to 20% faster with the W 50 R/W 50 Ri and W 60 R/W 60 Ri.

Technical specification

	W 50 R	W 60 R	W 50 Ri	W 60 Ri
Milling drum				
Milling width	500 mm	600 mm	500 mm	600 mm
Milling depth *1	0-210 mm	0-210 mm	0-210 mm	0-210 mm
Drum diameter with tools	750 mm	750 mm	750 mm	750 mm
Engine				
Engine manufacturer	Deutz		Deutz	
Type	TCD 2012 L04 V2		TCD 4,1 L4	
Cooling	water		water	
Number of cylinders	4		4	
Rated power at 2,100 min ⁻¹	100 kW/134 HP/136 PS		105 kW/141 HP/143 PS	
Maximum power at 2,100 min ⁻¹	100 kW/134 HP/136 PS		105 kW/141 HP/143 PS	
Displacement	4,100 cm ³		4,100 cm ³	
Fuel consumption at rated power	26.8 l/h		28.2 l/h	
Fuel consumption in field mix	10.8 l/h		11.3 l/h	
Emission standards	EC Stage 3a/US Tier 3		EC Stage 3b/US Tier 4i	
Electrical system				
Electrical power supply	24 V		24 V	
Tank capacities				
Fuel tank	230 l			
Hydraulic oil tank	63 l			
Water tank	600 l			
Driving properties				
Max. milling speed	0-48 m/min (0-2.9 km/h)			
Travel speed 3-wheeled model	0-133 m/min (0-8 km/h)			
Travel speed 4-wheeled model	0-200 m/min (0-12 km/h)			
Tyres				
Tyre size front, 3-wheeled or 4-wheeled model (Ø x W)	530 x 300 mm			
Tyre size rear, 3-wheeled or 4-wheeled model (Ø x W)	559 x 254 mm			
Loading of the milled material				
Belt width of discharge conveyor	350 mm			
Theoretical capacity of discharge conveyor	80 m ³ /h			

*1 = The maximum milling depth may deviate from the value indicated due to tolerances and wear.

	W 50 R	W 60 R	W 50 Ri	W 60 Ri
Weight of base machine				
Empty weight of machine, 3-wheeled model without conveyor and tank contents	6,430 kg	6,950 kg	6,430 kg	6,950 kg
Operating weight, CE* ² , 3-wheeled model without conveyor	6,930 kg	7,450 kg	6,930 kg	7,450 kg
Operating weight, max. (full tanks, full range of equipment)	9,695 kg	9,865 kg	9,695 kg	9,865 kg
Weights of tank contents				
Water tank filling	600 kg			
Diesel tank filling (0.83 kg/l)	190 kg			
Additional add-on weights				
Driver and tools				
Driver	75 kg			
Weight of 2 cutting tool containers	50 kg			
On-board tools	30 kg			
Optional milling drum assemblies in lieu of standard				
Milling drum housing FB500 with scraper system	360 kg	-	360 kg	-
Milling drum housing FB600 with scraper system	-	370 kg	-	370 kg
Optional milling drums in lieu of standard				
FCS milling unit FB400 HT08 LA15 incl. scraper bottom parts	-55 kg	-	-55 kg	-
FCS milling unit FB300 HT08 LA15 incl. scraper bottom parts	-105 kg	-	-105 kg	-
Milling drum FB80 HT02 MD210 with 24 picks	-163 kg	-190 kg	-163 kg	-190 kg
Milling drum FB300 HT08 LA15 with 47 picks	-86 kg	-	-86 kg	-
Milling drum FB400 HT08 LA15 with 54 picks	-45 kg	-	-45 kg	-
Micro-fine milling drum FB500 HT4 LA3 with 166 mini-picks	-64 kg	-	-64 kg	-
Fine Milling drum FB500 HT5 LA6 with 84 picks	5 kg	-	5 kg	-
Fine milling drum FB600 HT5 LA6 with 101 picks	-	3 kg	-	3 kg
Milling drum Eco-Cutter FB500 HT08 LA20 with 54 picks	-6 kg	-	-6 kg	-
Milling drum Eco-Cutter FB600 HT08 LA20 with 58 picks	-	-13 kg	-	-13 kg
Mounting side milling wheel FB80, MD300 compl.	-60 kg	-	-60 kg	-
Optional supplementary weights				
Supplementary weight for flexible use 1	380 kg	standard	380 kg	standard
Supplementary weight for flexible use 2	620 kg			
Optional additional equipment				
Discharge conveyor, 5,600 mm long, 350 mm wide (without scraper system)	480 kg			
Discharge conveyor 5,600 mm long, 350 mm wide, with hydraulic folding device (without scraper system)	560 kg			
Shortened discharge conveyor, 1,100 mm long, 350 mm wide (without scraper system)	210 kg			
4-wheeled model in lieu of 3-wheeled model	130 kg			
Canopy	150 kg			

*² = Weight of machine with half-full water tank, half-full fuel tank, driver (75 kg) and on-board tools, excluding optional equipment

Dimensions

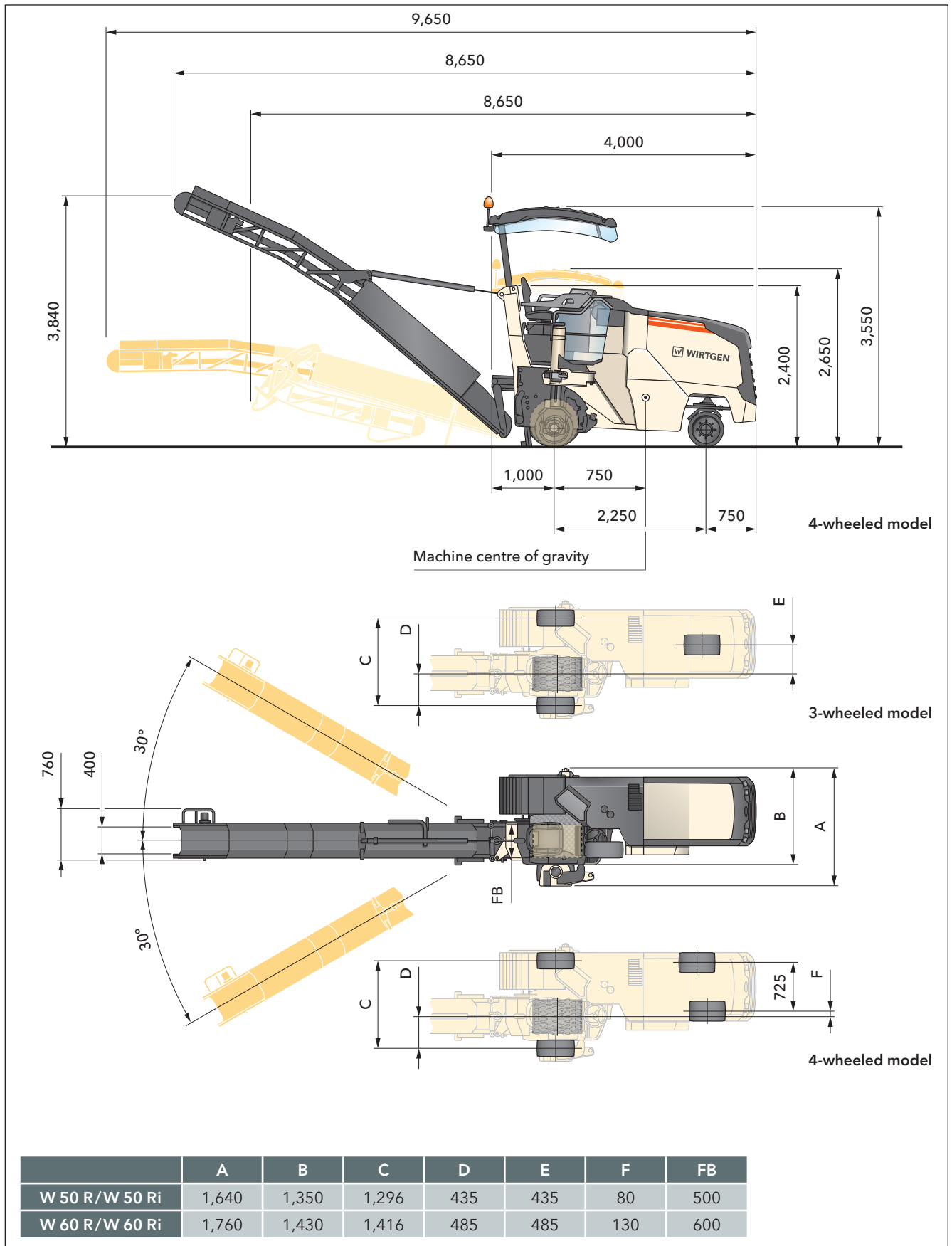

Dimensions in mm

3-wheeled model

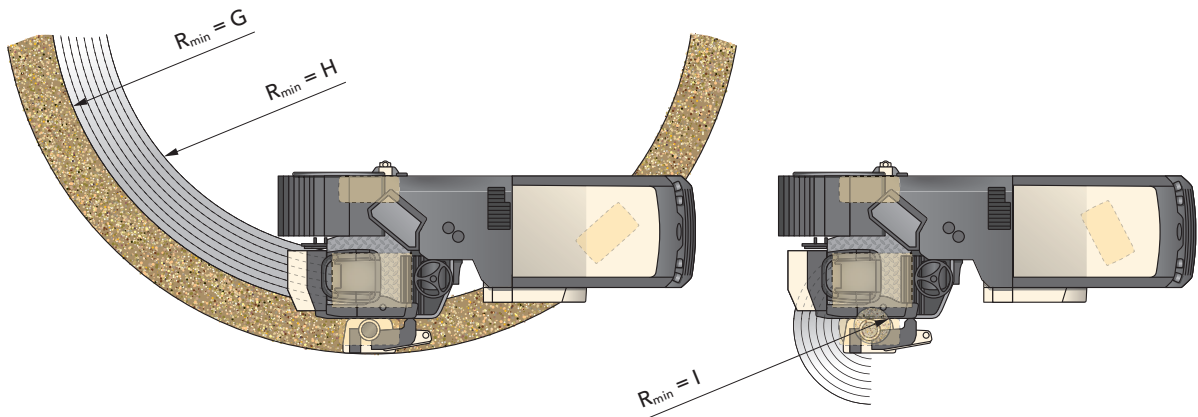

4-wheeled model

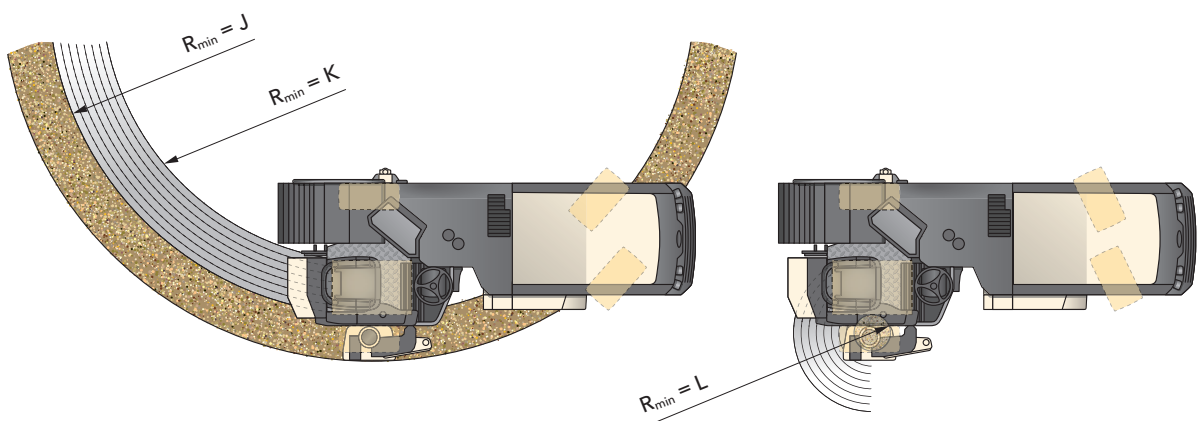

	3-wheeled model			4-wheeled model		
	G	H	I	J	K	L
W 50 R/W 50 Ri	2,900	2,400	150	2,350	1,850	150
W 60 R/W 60 Ri	3,000	2,400	50	2,450	1,850	50

Milling radius, 50 mm milling depth, dimensions in mm

Standard equipment

	W 50 R	W 60 R	W 50 Ri	W 60 Ri
Base machine				
Engine cover with noise insulation and flexibly decoupled engine mounting for especially quiet running and low noise emissions	■	■	■	■
Milling drum unit				
Automatically activating, hydraulic drive belt tensioner for reliable power transmission to the milling drum	■	■	■	■
Hydraulically lifting side plates with position measuring sensors in the hydraulic cylinders for measuring the milling depth.	■	■	■	■
Round milling drum housing and straight left side plate for optimum material transport, making for low left-over amounts when lifting out the milling drum	■	■	■	■
Prepared for using a scraper decoupled from the conveyor suspension for loading material using discharge conveyor	■	■	■	■
The right side of the milling drum housing can easily be folded down for maintenance or milling drum change	■	■	■	■
Optimised for quick change of the milling drum, including by using centring pins with the side door of the milling drum housing	■	■	■	■
With automatic electrical safety shut-off for the milling drum	■	■	■	■
Milling drum housing FB500 without scraper system, for use without discharge conveyor	□	—	□	—
Milling drum housing FB600 without scraper system, for use without discharge conveyor	—	□	—	□
Manually adjustable front milling drum unit seal FB500	□	—	□	—
Manually adjustable front milling drum unit seal FB600	—	□	—	□
Milling drums				
Milling drum FB500 HT08 LA15 with 60 picks	□	—	□	—
Milling drum FB600 HT08 LA15 with 70 picks	—	□	—	□
Milled-out material loading				
Machine prepared for optional material loading by discharge conveyor	■	■	■	■
Conveyor speed continuously variable	■	■	■	■
Conveyor slewing angle right/left 30 degrees each for significantly improved loading procedures	■	■	■	■
Slender conveyor suspension permits improved visibility to the rear	■	■	■	■
Machine without hydraulic preliminary equipment for a discharge conveyor	□	□	□	□
Machine without preliminary belt equipment and discharge conveyor	□	□	□	□
Operator's stand				
Operator's stand with ergonomically arranged operator's seat, control panel arranged on the right and digital milling depth indicator in the control display	■	■	■	■
Steering console with adjustable rake and reach for ideal adaptation of the operator's stand to the operator	■	■	■	■

- = Standard equipment
- = Standard equipment, replaceable with optional equipment
- = Optional equipment

	W 50 R	W 60 R	W 50 Ri	W 60 Ri
Operator's stand				
2 rear-view mirrors left	■	■	■	■
Machine design permits unobstructed view of the milled edge at the right and left as well as the working area in front of the milling drum on the right	■	■	■	■
Conveniently accessible ladder/footstep to the operator's stand with night-time lighting and especially low, folding bottom edge of the latter/footstep	■	■	■	■
Robust anti-vandalism protection for the controls	■	■	■	■
Standard operator's seat	□	□	□	□
Under-carriage and height adjustment				
Precise machine height adjustment in 1 or 5 mm steps from the machine control panel	■	■	■	■
Infinitely variable, hydraulic all-wheel drive with three speed ranges	■	■	■	■
Digital load control, manual engageable, hydraulic differential lock (by flow distributor)	■	■	■	■
Particularly wide solid rubber tyres (300 mm) for the lowest ground pressures and optimum traction	■	■	■	■
For milling along kerb edges, the rear right support wheel can be swivelled hydraulically from the operator's stand in front of the milling drum. In addition, the machine does not have to be lowered.	■	■	■	■
Hydraulic spring-loaded brake	■	■	■	■
Proportional height adjustment at rear	■	■	■	■
3-wheel crawler unit	□	□	□	□
Others				
Optimised centre of gravity position, irrespective of the filling levels of the water and fuel tanks	■	■	■	■
Flexible weight concept by optional additional weights	■	■	■	■
Particularly low machine centre of gravity for high stability of the machine	■	■	■	■
Robust and easily maintained machine chassis with optimum ground clearance and short overhangs	■	■	■	■
Device for towing away	■	■	■	■
Reversing horn	■	■	■	■
Large tool package with lockable tool box and additional storage space for two pick buckets	■	■	■	■
European type test certificate and CE conformity	■	■	■	■
Paint standard cream white RAL 9001	□	□	□	□
Halogen lighting package including rotary beacon	□	□	□	□

■ = Standard equipment
 □ = Standard equipment, replaceable with optional equipment
 □ = Optional equipment

Optional equipment

	W 50 R	W 60 R	W 50 Ri	W 60 Ri
Milling drum unit				
Milling drum housing FB500 with scraper system, for use with discharge conveyor	<input type="checkbox"/>	-	<input type="checkbox"/>	-
Milling drum housing FB600 with scraper system, for use with discharge conveyor	-	<input type="checkbox"/>	-	<input type="checkbox"/>
Hydraulically adjustable front milling drum unit seal FB500, incl. overload sensor	<input type="checkbox"/>	-	<input type="checkbox"/>	-
Hydraulically adjustable front milling drum unit seal FB600, incl. overload sensor	-	<input type="checkbox"/>	-	<input type="checkbox"/>
Overload sensor on the scraper FB500/600	<input type="checkbox"/>	<input type="checkbox"/>	<input type="checkbox"/>	<input type="checkbox"/>
Active floating position for the right and left side plates	<input type="checkbox"/>	<input type="checkbox"/>	<input type="checkbox"/>	<input type="checkbox"/>
Milling drums				
FCS milling unit FB400 HT08 LA15 incl. scraper bottom parts	<input type="checkbox"/>	-	<input type="checkbox"/>	-
FCS milling unit FB300 HT08 LA15 incl. scraper bottom parts	<input type="checkbox"/>	-	<input type="checkbox"/>	-
Milling drum FB80 HT02 MD210 with 24 picks	<input type="checkbox"/>	<input type="checkbox"/>	<input type="checkbox"/>	<input type="checkbox"/>
Milling drum FB300 HT08 LA15 with 47 picks	<input type="checkbox"/>	-	<input type="checkbox"/>	-
Milling drum FB400 HT08 LA15 with 54 picks	<input type="checkbox"/>	-	<input type="checkbox"/>	-
Micro-fine milling drum FB500 HT4 LA3 with 166 mini-picks	<input type="checkbox"/>	-	<input type="checkbox"/>	-
Fine Milling drum FB500 HT5 LA6 with 84 picks	<input type="checkbox"/>	-	<input type="checkbox"/>	-
Fine milling drum FB600 HT5 LA6 with 101 picks	-	<input type="checkbox"/>	-	<input type="checkbox"/>
Milling drum Eco-Cutter FB500 HT08 LA20 with 54 picks	<input type="checkbox"/>	-	<input type="checkbox"/>	-
Milling drum Eco-Cutter FB600 HT08 LA20 with 58 picks	-	<input type="checkbox"/>	-	<input type="checkbox"/>
Mounting side milling wheel FB80, MD300 complete	<input type="checkbox"/>	-	<input type="checkbox"/>	-
Milled-out material loading				
Machine with hydraulic preliminary equipment for a discharge conveyor-screw coupling	<input type="checkbox"/>	<input type="checkbox"/>	<input type="checkbox"/>	<input type="checkbox"/>
Machine with hydraulic preliminary equipment for a discharge conveyor-quick-change coupling	<input type="checkbox"/>	<input type="checkbox"/>	<input type="checkbox"/>	<input type="checkbox"/>
Lid for closing the ejection opening when the loading belt is removed.	<input type="checkbox"/>	<input type="checkbox"/>	<input type="checkbox"/>	<input type="checkbox"/>
Discharge conveyor, 5,600 mm long, 350 mm wide	<input type="checkbox"/>	<input type="checkbox"/>	<input type="checkbox"/>	<input type="checkbox"/>
Shortened discharge conveyor, 1,100 mm long, 350 mm wide	<input type="checkbox"/>	<input type="checkbox"/>	<input type="checkbox"/>	<input type="checkbox"/>
Discharge conveyor 5,600 mm long, 350 mm wide, with hydraulic folding device	<input type="checkbox"/>	<input type="checkbox"/>	<input type="checkbox"/>	<input type="checkbox"/>
Additional shortened discharge conveyor, 1,100 mm long, 350 mm wide	<input type="checkbox"/>	<input type="checkbox"/>	<input type="checkbox"/>	<input type="checkbox"/>
Hydraulic connection adapter screw coupling for additional discharge conveyor	<input type="checkbox"/>	<input type="checkbox"/>	<input type="checkbox"/>	<input type="checkbox"/>
Hydraulic connection adapter quick-change coupling for additional discharge conveyor	<input type="checkbox"/>	<input type="checkbox"/>	<input type="checkbox"/>	<input type="checkbox"/>
Material chute for discharging the milled material to the right side	<input type="checkbox"/>	<input type="checkbox"/>	<input type="checkbox"/>	<input type="checkbox"/>

- = Standard equipment
- = Standard equipment, replaceable with optional equipment
- = Optional equipment

	W 50 R	W 60 R	W 50 Ri	W 60 Ri
Machine control and levelling system				
LEVEL PRO PLUS levelling system right and left	<input type="checkbox"/>	<input type="checkbox"/>	<input type="checkbox"/>	<input type="checkbox"/>
RAPID SLOPE sensor for LEVEL PRO PLUS levelling system	<input type="checkbox"/>	<input type="checkbox"/>	<input type="checkbox"/>	<input type="checkbox"/>
Levelling boom including sensor for LEVEL PRO PLUS levelling system	<input type="checkbox"/>	<input type="checkbox"/>	<input type="checkbox"/>	<input type="checkbox"/>
Operator's stand				
Comfort operator's seat incl. seat heating	<input type="checkbox"/>	<input type="checkbox"/>	<input type="checkbox"/>	<input type="checkbox"/>
Operator's stand with weather canopy and lateral weather protection elements	<input type="checkbox"/>	<input type="checkbox"/>	<input type="checkbox"/>	<input type="checkbox"/>
Under-carriage and height adjustment				
4-wheel crawler unit	<input type="checkbox"/>	<input type="checkbox"/>	<input type="checkbox"/>	<input type="checkbox"/>
Precision steering by pushbuttons for machine with 3-wheel chassis (up to 8 km/h)	<input type="checkbox"/>	<input type="checkbox"/>	<input type="checkbox"/>	<input type="checkbox"/>
Precision steering by pushbuttons for machine with 4-wheel chassis (up to 12 km/h)	<input type="checkbox"/>	<input type="checkbox"/>	<input type="checkbox"/>	<input type="checkbox"/>
Increased travelling speed (3-wheel up to 8 km/h, 4-wheel up to 12 km/h)	<input type="checkbox"/>	<input type="checkbox"/>	<input type="checkbox"/>	<input type="checkbox"/>
Others				
Paint in one special colour (RAL)	<input type="checkbox"/>	<input type="checkbox"/>	<input type="checkbox"/>	<input type="checkbox"/>
Paint in two special colours (RAL)	<input type="checkbox"/>	<input type="checkbox"/>	<input type="checkbox"/>	<input type="checkbox"/>
Paint in maximum 2 special colours with substructure in special colour (RAL)	<input type="checkbox"/>	<input type="checkbox"/>	<input type="checkbox"/>	<input type="checkbox"/>
High-power lighting package LED including rotary beacon	<input type="checkbox"/>	<input type="checkbox"/>	<input type="checkbox"/>	<input type="checkbox"/>
Additional weight 380 kg behind the front axle	<input type="checkbox"/>	–	<input type="checkbox"/>	–
Additional weight 620 kg on underbody	<input type="checkbox"/>	<input type="checkbox"/>	<input type="checkbox"/>	<input type="checkbox"/>
Milling drum assembly trolley for milling drums up to FB600	<input type="checkbox"/>	<input type="checkbox"/>	<input type="checkbox"/>	<input type="checkbox"/>
Electric preheating of the fuel filter	–	–	<input type="checkbox"/>	<input type="checkbox"/>
Hydraulic connection for additional devices on the rear of the machine	<input type="checkbox"/>	<input type="checkbox"/>	<input type="checkbox"/>	<input type="checkbox"/>
Powerful hydraulic hammer with 10 m connection hose.	<input type="checkbox"/>	<input type="checkbox"/>	<input type="checkbox"/>	<input type="checkbox"/>
Hydraulically driven water filler pump (72 l/minute at max. 6 bar)	<input type="checkbox"/>	<input type="checkbox"/>	<input type="checkbox"/>	<input type="checkbox"/>
Sweeping unit with disk brush	<input type="checkbox"/>	<input type="checkbox"/>	<input type="checkbox"/>	<input type="checkbox"/>
Hydraulically driven pick ejector drift	<input type="checkbox"/>	<input type="checkbox"/>	<input type="checkbox"/>	<input type="checkbox"/>
Monitor system with 1 camera and screen	<input type="checkbox"/>	<input type="checkbox"/>	<input type="checkbox"/>	<input type="checkbox"/>
Monitor system with 2 cameras and screen	<input type="checkbox"/>	<input type="checkbox"/>	<input type="checkbox"/>	<input type="checkbox"/>
WITOS FleetView telematics system incl. 3-year operating period	–	–	<input type="checkbox"/>	<input type="checkbox"/>
WITOS FleetView telematics system incl. 3-year operating period - PROMOTION	–	–	<input type="checkbox"/>	<input type="checkbox"/>

= Standard equipment
 = Standard equipment, replaceable with optional equipment
 = Optional equipment



WIRTGEN GmbH

Reinhard-Wirtgen-Str. 2 · 53578 Windhagen · Germany
Phone: +49 (0)26 45/131-0 · Fax: +49 (0)26 45/131-392
Internet: www.wirtgen.com · E-Mail: info@wirtgen.com