



Technical specification

Slipform Paver SP 500



Slipform Paver SP 500, basic machine

Vibrators and circuits	Hydraulic vibration	8 connections (optional: 16 connections)
	Electric vibration	12 connections (optional: 18 connections)
	Hydraulically driven vibrators	straight and curved
	Electrically driven vibrators	straight and curved
Engine	Engine manufacturer	Deutz
	Type	TCD 2012 L06 2V
	Cooling	water
	Number of cylinders	6
	Rated power at 2,100 min ⁻¹	129.4 kW/174 HP/176 PS
	Displacement	6,057 cm ³
	Fuel consumption, full load	35.8 l/h
	Fuel consumption, field mix	16.2 l/h
	Emission standards	EPA Tier III, 2004/26/EC, Stage IIIa
	Electrical system	Supply voltage
Electric vibration (option)		110V AC 3~ / 200 Hz
Filling capacities	Fuel tank	350 l
	Hydraulic fluid tank	380 l
	Water tank	475 l
Driving characteristics	Paving speed	0 to 5 m/min
	Travel speed	0 to 18 m/min
Crawler tracks	Number	3 or 4
	Dimensions (L x W x H)	1,550 mm x 300 mm x 450 mm
Height adjustment	Hydraulic	1,000 mm
	Mechanical (hole pattern)	280 mm

Slipform Paver SP 500, slab paving

Scope of applications	Slab paving application	paving width: 2.00 to 6.00 m ^{*1} paving thickness: up to 400 mm ^{*1}
Concrete spreading	Spreading plough	modular extension to up to 6.00 m
	Spreading auger	modular extension to up to 6.00 m
Slab paving equipment	Slab paving mould	modular extension to up to 6.00 m
	Finishing beam	modular extension to up to 6.00 m
	Super smoother	modular extension to up to 6.00 m
	Dowel bar inserter	modular extension to up to 6.00 m Ø dowel bars: 20 to 40 mm ^{*2} dowel bar length: 450 to 600 mm ^{*2}
	Side tie bar inserter	Ø tie bars: 20 to 40 mm ^{*3} , tie bar length: 400 to 800 mm ^{*3}
Camber		gradient up to 3 %
Transport dimensions (L x W x H)	Machine with slab paving mould, 6.00 m	10,800 mm x 2,550 mm x 3,100 mm
	Machine with slab paving mould, 6.00 m, spreading plough, finishing beam and super smoother	10,800 mm x 2,950 mm x 3,100 mm
	Machine with slab paving mould, 6.00 m, spreading auger, finishing beam and super smoother	10,800 mm x 3,150 mm x 3,100 mm
	Fully equipped machine, 6.00 m, including dowel bar inserter	10,800 mm x 3,500 mm x 3,100 mm
Machine weights ^{*4}	Empty weight (without concrete spreading equipment, with mould, without finishing equipment, without dowel bar inserter, without diesel/water), 6.00 m	29,600 daN (kg)
	Operating weight CE (with concrete spreading equipment, with mould, without finishing equipment, without dowel bar inserter), 6.00 m	30,700 daN (kg)
	Operating weight CE (with concrete spreading equipment, with mould, with finishing beam and super smoother, without dowel bar inserter), 6.00 m	32,500 daN (kg)
	Max. operating weight CE (fully equipped machine including dowel bar inserter), 6.00 m	39,000 daN (kg)

^{*1} = Please consult factory for special paving widths, paving thicknesses and options.

^{*2} = The range of dowel bar dimensions specified above can be covered. For any other dimensions, please consult factory. The dowel bar inserters will be customized in accordance with the pre-selected customer requirement.

^{*3} = The range of tie bar dimensions specified above can be covered. For any other dimensions, please consult factory. The side tie bar inserters will be customized in accordance with the pre-selected customer requirement.

^{*4} = Weights depend on the machine's range of equipment and working width.

Slipform Paver SP 500, offset paving

Scope of applications	Offset application	optional mounting left or right paving width: up to 3,000 mm ^{*5} offset height: up to 2,200 mm ^{*5}
Concrete feeding	Belt conveyor	standard
	Auger conveyor	option
Mould	Mould	to customer specification (option)
Trimmer (option)	Diameter with tools	500 mm
	Basic width	750 mm
	Extension elements	250 mm/300 mm/350 mm ^{*6}
	Max. width	1,650 mm
	Trimming depth	100 mm
	Height adjustment, hydraulic	400 mm
	Height adjustment, mechanical (hole pattern)	300 mm
	Two-stage lateral telescoping	1,900 mm
Transport dimensions (L x W x H)	Machine (without belt conveyor/auger conveyor)	6,800 mm x 2,550 mm x 3,100 mm
	Machine (with belt conveyor)	8,800 mm x 2,550 mm x 3,100 mm
	Machine (with auger conveyor)	7,800 mm x 2,550 mm x 3,100 mm
Machine weights ^{*4}	Empty weight (without trimmer, with belt conveyor, without mould, without diesel/water)	15,800 daN (kg)
	Operating weight CE (without trimmer, with belt conveyor)	16,600 daN (kg)
	Auger conveyor	1,300 daN (kg)
	Belt conveyor	850 daN (kg)
	Max. operating weight CE (with trimmer, with auger conveyor and curb and gutter profile mould)	18,800 daN (kg)

^{*4} = Weights depend on the machine's range of equipment and working width.

^{*5} = Please consult factory for different offset geometries or special applications.

^{*6} = Please consult factory for special widths.

SP 500, offset paver
Dimensions in mm

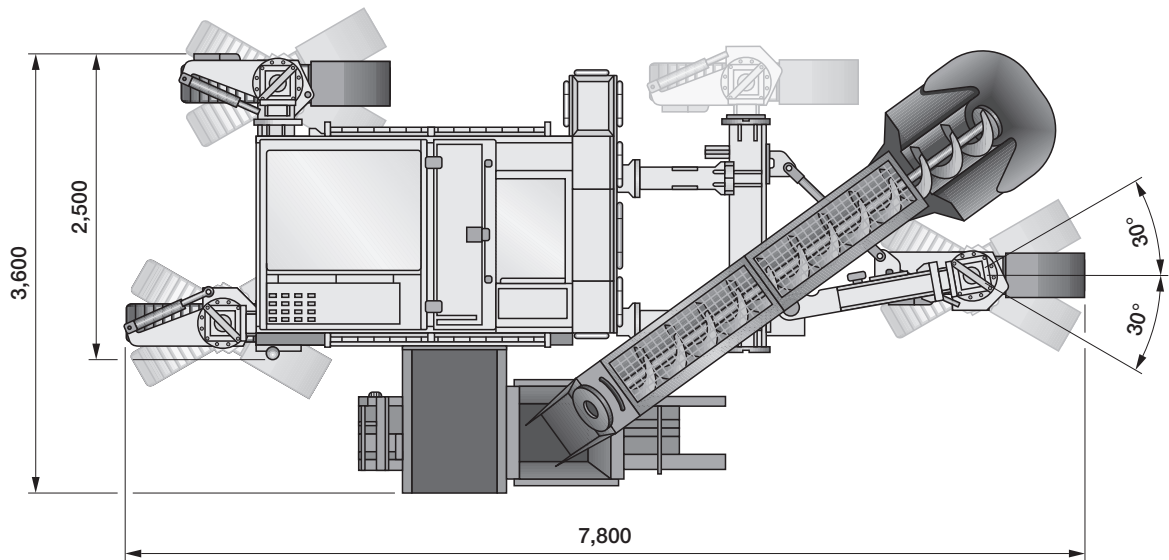
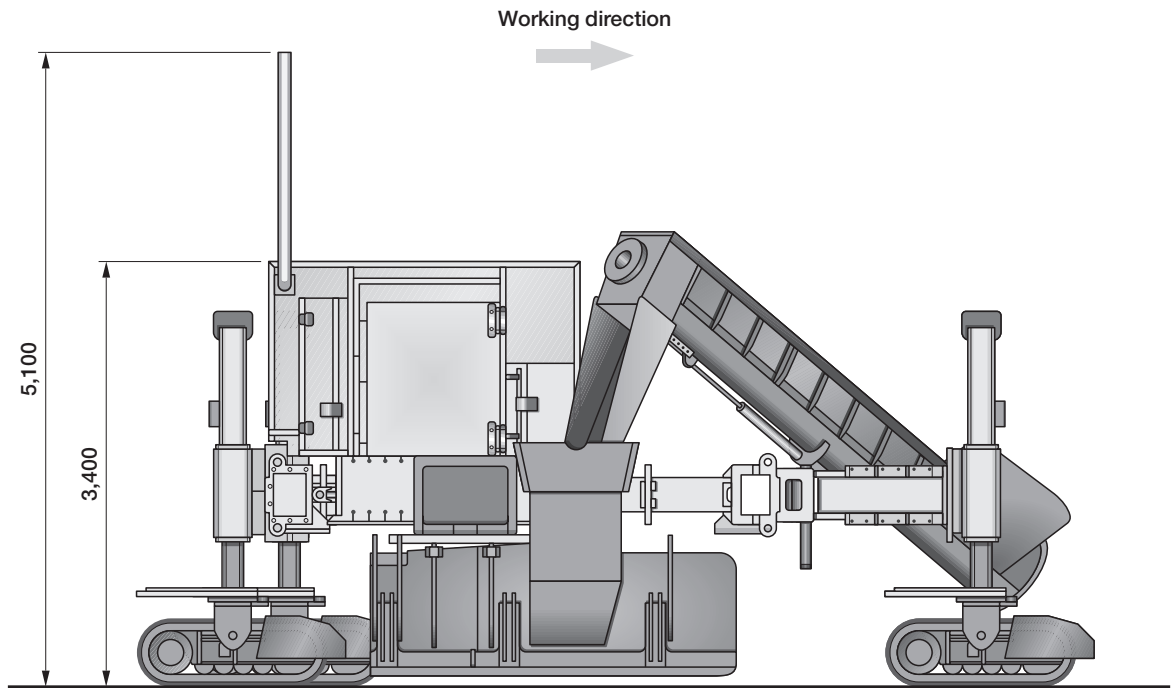

SP 500, offset paver with pivoting legs

Dimensions in mm

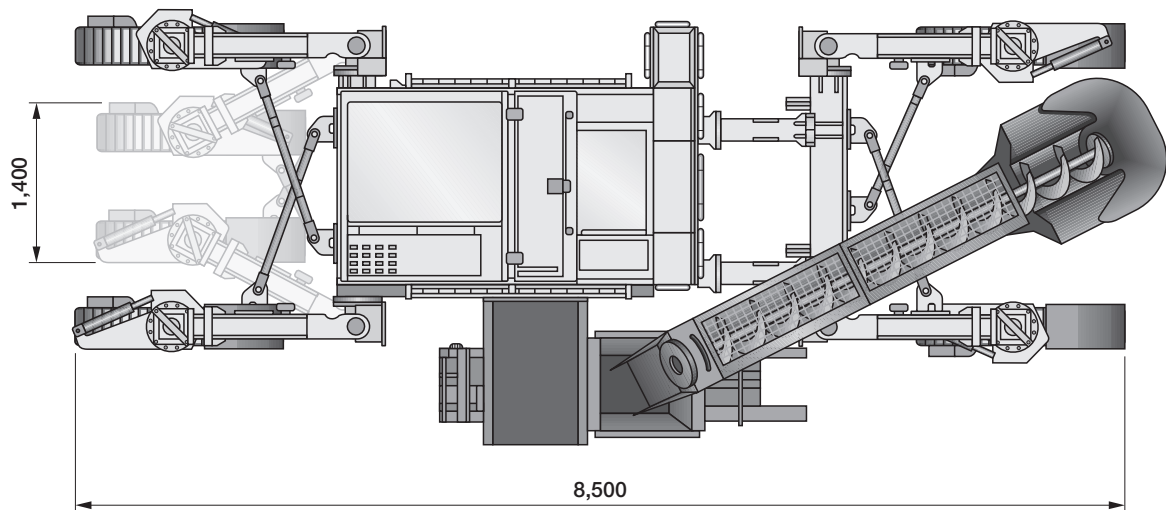
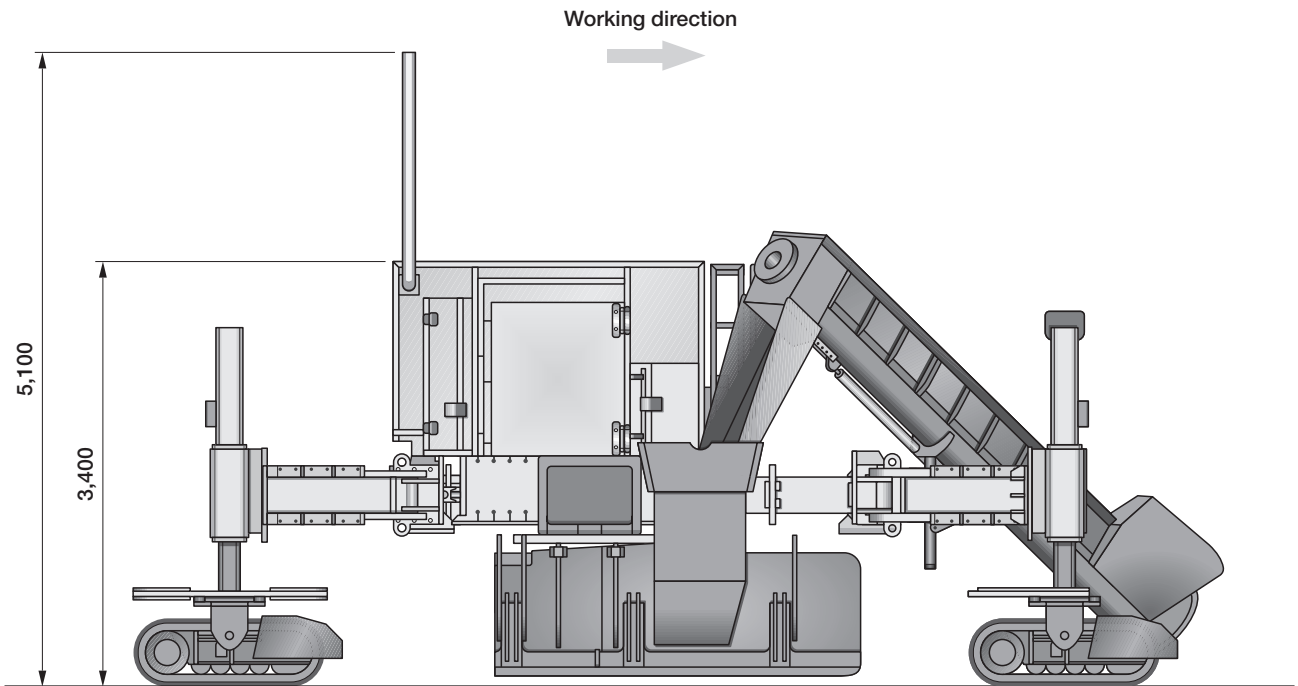

Basic equipment of SP 500, slab paver
Dimensions in mm

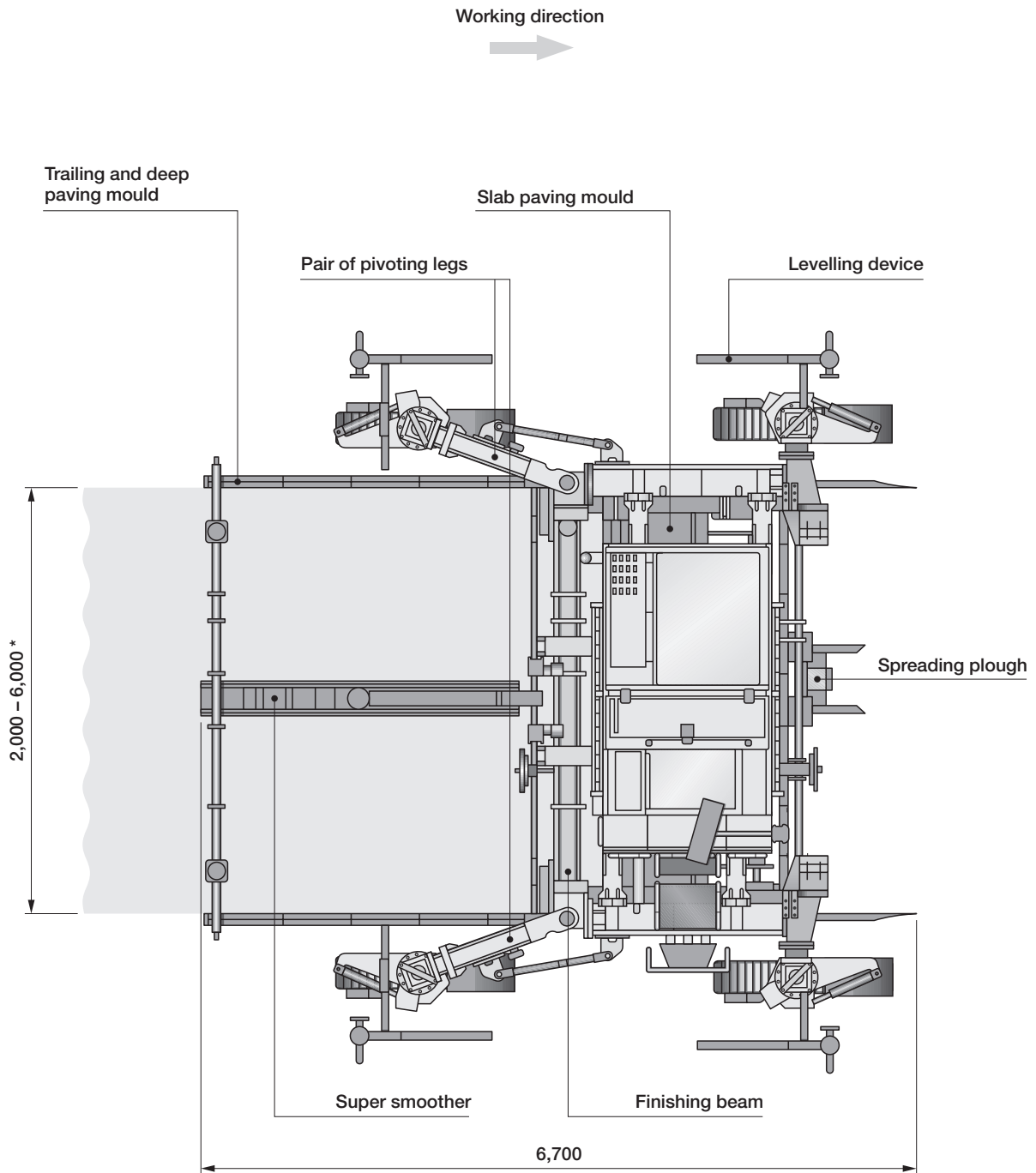

* = Please consult factory for special paving widths

Optional equipment SP 500, slab paver
Dimensions in mm

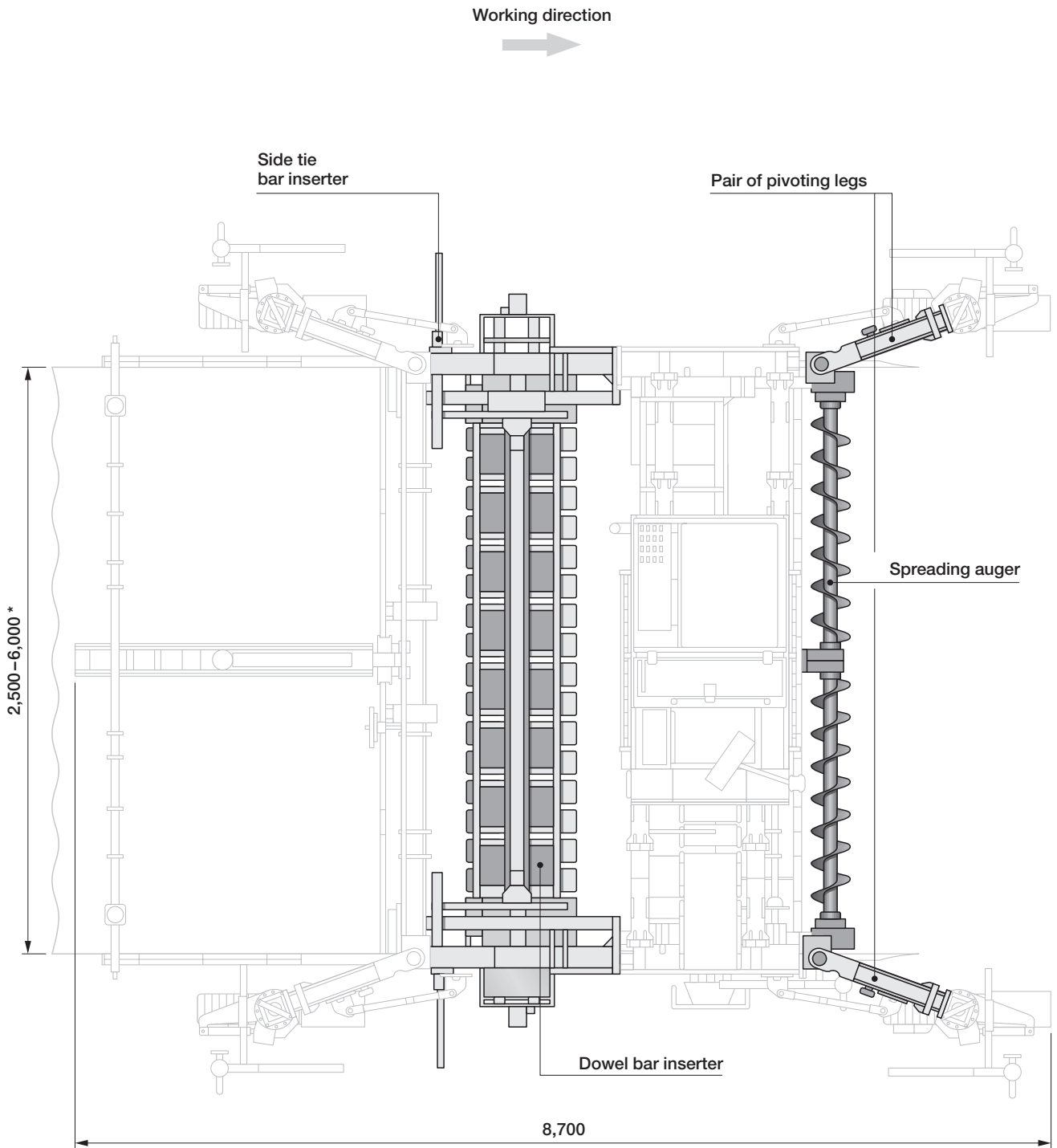

* = Please consult factory for special paving widths

Dowel bar inserter (option)

Dimensions in mm

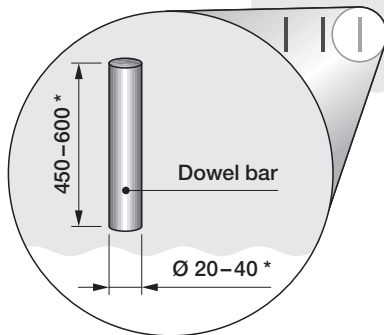
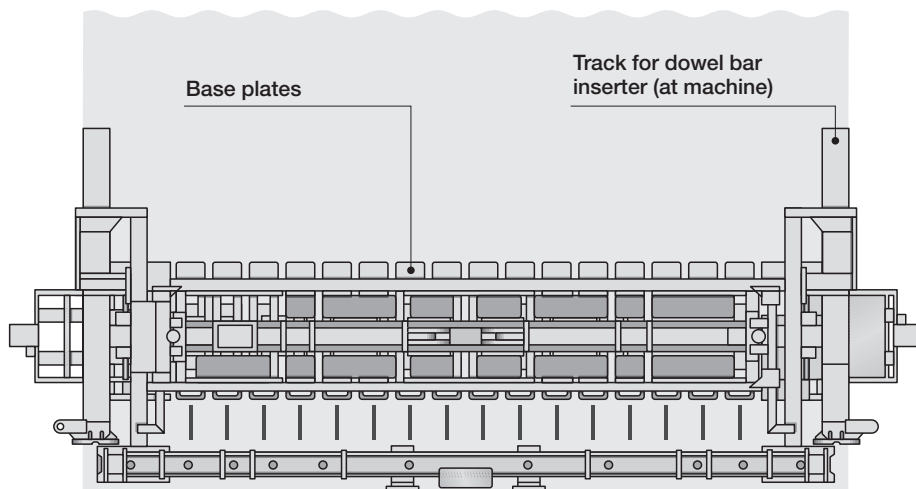
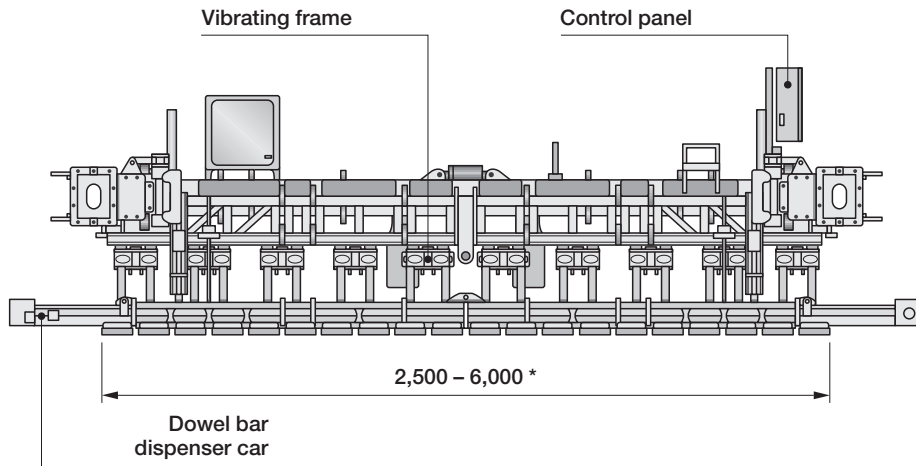

* = The range of dowel bar dimensions specified above can be covered. For any other dimensions, please consult factory. The dowel bar inserters will be customized in accordance with the pre-selected customer requirement.

Equipment features SP 500 slipform paver

Standard equipment:

Operator's platform

- Convenient control panel with practical switches
- Digital LC display with rotary buttons/push buttons to display all major operating parameters and to key in job parameters
- Lockable control panel cover
- Removable main control panel

Levelling

- Slope sensor for detection of the machine's cross slope
- Two level sensors
- Two steering sensors

Vibration

- 8 connections for hydraulic vibration (separately adjustable)

Concrete equipment for slab paving

- Slab paving mould for the paving of 2.00 m wide concrete slabs, including hydraulic sideplates
- Trailing and deep paving mould for concrete slabs of 200 mm and 260 mm

Chassis and height adjustment

- 3-fold height control with high-precision valve technology
- Adjustment to site conditions through various mounting options

Machine control

- Comfort feature for quick-starting all necessary paving functions following stand-by position
- A single PLC governs all machine functions
- Integrated engine controller for optimum engine control
- Switching function to quickly change from transverse to longitudinal travel, e.g. when converting the paver from slab paving to offset paving

Engine

- Anti-vibration engine support in rubber mounts
- Highly effective triple-circuit water cooler for engine, hydraulic oil and charge air

Miscellaneous

- Lighting package with 3 halogen spotlights

Optional equipment:

Operator's platform

- Canopy
- Ventilation of control cabinet

Levelling

- 3D kit to support 3D control systems
- Slab tracer for sensing a reference surface

Vibration

- 8 additional connections for hydraulic vibration
- Electric vibration with 20-kVA generator and 12 connections
- Electric vibration with 40-kVA generator and 18 connections
- Electric vibrators (straight or curved)
- Hydraulic vibrators (straight or curved)

Chassis and height adjustment

- Extremely wear-resistant polyurethane track pad equipment
- Pair of pivoting legs each front and rear to allow adjustment to site conditions

Concrete spreading

- Spreading plough
- Spreading auger (optionally including camber)

Concrete equipment for slab paving

- Extension elements for slab paving mould up to 6.00 m (optionally including camber)
- Finishing beam up to 6.00 m (optionally including camber)
- Super smoother extension up to 6.00 m
- Dowel bar inserter up to 6.00 m (optionally including camber)
- Side tie bar inserters

Concrete equipment for offset paving

- Mould mount to allow offset paving on the left or right side
- Offset moulds to customer specification
- Trimmer with standard width of 750 mm (can be extended to up to 1,650 mm)
- Concrete feeding via belt conveyor or auger conveyor

Miscellaneous

- Special painting
- Lighting package with 4 floodlights (110 V)
- High-pressure water cleaner
- Stakes and wire kit
- Tension winch
- Hydraulically driven hoisting crane for dowel bar packages



Wirtgen GmbH
Reinhard-Wirtgen-Strasse 2 · 53578 Windhagen · Germany
Phone: +49 (0) 26 45/131-0 · Fax: +49 (0) 26 45/131-242
Internet: www.wirtgen.com · E-Mail: info@wirtgen.com