

World class in performance and productivity.

# Cold Milling Machine W 250i



WIRTGEN

WIRTGEN

# Outstanding features of the W 250i cold milling machine

02  
03

4 |

## MACHINE FRAME

- > **Perfect visibility**  
Slender machine frame design at the front including dual wasp waist for a perfect view of the milling edge.
- > **Ease of transport**  
Ease of transport due to variable supplementary weights of up to 1,500 kg.

3 |

## ENGINE STATION

- > **Dual Engine Concept**  
Dual engine concept for extra low diesel consumption and high milling performance.
- > **Three different milling drum speed options**  
Three selectable cutting speeds for optimum milling performance in a broad range of applications.
- > **Load-controlled fan speed**  
Fan speed governed by engine temperature for low energy consumption and low noise emission levels.

2 |

## ELECTRICAL SYSTEM

- > **Emergency operation**  
Electrohydraulic power pack to raise machine in emergency mode.
- > **Camera system**  
Robust camera system including up to six cameras and up to two screens.
- > **Job data**  
Precise recording of job data including "truck full" message.

1 |

## LEVELLING

- > **Large choice of sensors**  
LEVEL PRO automatic levelling system as standard equipment, offering a large choice of sensors and highly precise control of the milling depth.
- > **Milling depth indicator**  
Milling depth indicator on the LEVEL PRO screen (showing difference between scraper blade and side plate positions).
- > **Scanning in front of the milling drum**  
Scanning in front of the milling drum via hydraulic cylinders with integrated measuring system - suitable for use also with the Multiplex system.
- > **Automatic system to initiate the milling process**  
Automatic system to initiate the milling process with load-controlled lowering speed.





5 |

## OPERATOR'S PLATFORM

### > Multifunctional joystick

Multifunctional joystick with driving, steering, selecting operating mode, raising machine and switching off conveyor functions.

### > Ergonomics

Ergonomically designed, backlit controls for non-tiring, productive working.

### > Hydraulically moving and swivelling operator's cabin

Optionally available Operator Comfort System (OCS) for an ideal working environment.

### > Protective canopy

Protective canopy with telescoping side panels for maximum protection from inclement weather.

### > Parallel alignment of machine

Automatic parallel alignment of the machine both during the milling operation and in transport mode.

6 |

## CONVEYOR SYSTEM

### > Large slewing angles

Conveyor slewing angles of 60° to both sides to optimize the loading process.

### > Tremendous conveying capacity

High conveyor loading capacity and drive power for highly efficient material loading.

### > Vacuum Cutting System

Vacuum Cutting System for improved visibility.

### > Folding conveyor with locking mechanism

Folding conveyor with intelligent mechanical locking mechanism for easy transport.



7 |

## MILLING DRUM UNIT

### > Locking of scraper blade

Automatic mechanical locking of scraper blade to ensure ease of operation.

### > FCS LIGHT

FCS Light for the quick replacement of milling drums when equipped with the FB2200 milling drum unit.

### > HT22 quick-change toolholder system

Extra efficient, tried-and-tested HT22 quick-change toolholder system as standard equipment.

### > Right-hand side plate lift of 450 mm

Right-hand side plate can be raised by up to 450 mm to allow flush-to-kerb milling at the full milling depth.

### > Load-controlled water spray system

Water spray system with automatic adjustment to the milling performance for optimum tool cooling.

### > Milling drum turning device

Drum turning device to enable cutting tool replacement with the diesel engine switched off.

8 |

## TRACTION DRIVE

### > Hydraulic pre-tensioning of track chains

Hydraulically pre-tensioned track chains for optimized operation.

### > Traction control

Intelligent electronic traction control system for the track units.

### > Track speed adjustment

Electronic adjustment of the track speed during cornering to ensure maximum traction and low wear and tear.

### > Four-fold full-floating axle

Four-fold full-floating axle for optimum machine stability.





Equipped with the skills  
to complete the really big jobs.



THE WIRTGEN W 250i LARGE MILLING MACHINE. EPITOME OF STRENGTH, PERFORMANCE AND EFFICIENCY. INCREDIBLE POWER ENABLES THE W 250i HIGH-PERFORMANCE MILLING MACHINE TO DIG ITS WAY THROUGH THE ASPHALT PAVEMENT. SEEMINGLY EFFORTLESS. TRIED-AND-TESTED, INNOVATIVE TECHNOLOGIES GIVE YOU THE DECISIVE LEAD ON THE REALLY BIG JOBS. THE CUTTING EDGE OF TECHNOLOGICAL PROGRESS. THE TOP PERFORMER IN PRODUCTIVITY.





*The W 250i excels in the quick completion of large-scale milling projects.*

## Designed with sheer efficiency in mind

### HIGH-PERFORMANCE COLD MILLING MACHINE W 250i

Maximize productivity while minimizing operating costs - this maxim is the key for construction projects that require large pavement areas to be milled at record speed. Tremendous engine power makes the W 250i high-end cold milling machine from WIRTGEN a top performer which completes even the toughest jobs with maximum efficiency. But the large milling machine has even more to offer: the WIDRIVE machine management system, which relieves the operator of a significant part of his

workload, ensures a fuel-efficient, environmentally friendly milling operation.

Further highlights include the ISC (Intelligent Speed Control) track control system, unique PTS automatic parallel alignment feature and six different working widths ranging from 2.20 m to 4.40 m.

It goes without saying that, owing to its innovative Dual Engine Concept, the W 250i is a role model in economic efficiency also during phases in which performance requirements are low.





1 | The large milling machine is removing the pavement at high advance rates.

2 | Ergonomically optimized design and ease of operation prevent fatigue during work.



# Unlimited milling performance

## UNRIVALLED IN THE LARGE MILLING MACHINE CLASS

Each type of pavement removed by the W 250i is instantly crushed into small-sized material by the top-performing machine at tremendous advance rates. Milling extensive areas on motorways or airports is therefore

no big deal at all. The machine's intelligent WIDRIVE management system, state-of-the-art Dual Engine Concept and choice of different engine or milling drum speeds are extremely useful features on such challenging large-scale construction projects: they contribute to significantly reducing the overall operating costs.

In addition to the highly economical milling of individual layers, complete road pavements can also be removed in a single machine pass. Perfect truck logistics enable the W 250i to remove up to 1,200 tonnes per hour of asphalt - which is equivalent to the payload of 60 trucks. The high-performance W 250i is the ideal choice also for large-scale projects that need to be completed on schedule under tremendous deadline pressure.







# Optimum milling performance - whatever the job

## CHOICE OF THREE DIFFERENT MILLING DRUM SPEEDS

A smart feature assists the machine operator in optimizing diesel fuel consumption, milling performance and thus the overall efficiency of the W 250i: adjustment of the milling drum speed from the operator's platform. It guarantees optimum milling performance levels regardless of conditions and across a wide range of applications.

The W 250i usually operates at the medium milling drum speed when carrying out standard milling jobs, such as milling a surface course. The high speed is selected for the large-scale milling of thin pavement layers at high machine advance rates. Low speed is the right choice if maximum milling performance levels are to be achieved at the lowest possible cost: it guarantees reduced fuel consumption rates and low cutting tool wear.

## DIFFERENT MILLING DRUM SPEEDS FOR SPECIFIC MILLING JOBS

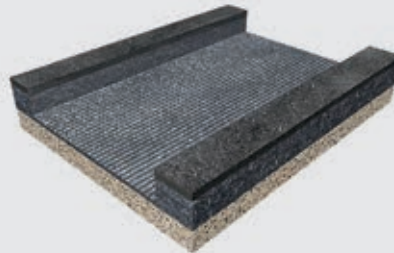

**Low speed:**  
complete removal at full depth

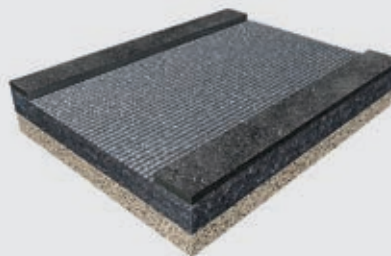

**Medium speed:**  
milling of surface courses,  
thin road pavements etc.



**High speed:** fine milling









High performance –  
convenient operation.

RELY ON THE W 250i TO COMPLETE YOUR JOB AT TOP PERFORMANCE RATES. EASY, INTUITIVE OPERATION GIVES YOU FULL CONTROL OF THE PROCESS. FAMILIAR WITH THE W 250i QUICKLY. ADD TO THIS UNMATCHED ERGONOMICS, COMFORT AND VISIBILITY ON THE OPERATOR'S PLATFORM. INNOVATIVE COMPUTER-ASSISTED SYSTEMS FACILITATE EVERYDAY WORK. EASE OF OPERATION AND HIGH PRODUCTIVITY BECOME ONE.





## High-tech - yet easy to operate

### CONTROLLING THE W 250i WITH EASE

The innovative operating concept implemented in the W 250i supports the operator and keeps him up-to-date on everything he needs to know. The control panels on the left and right have identical features and are individually adjustable, thus allowing ease of operation on both sides of the machine. Together with the LEVEL PRO control panel, the multifunctional control screen can be swivelled to both sides to always face the machine operator. It keeps the operator informed of all important machine and operation parameters. All controls are located within easy reach and in the operator's field of view. They are labelled

in a language-neutral manner and allow easy and intuitive operation. In the final analysis, the operator is familiar with the W 250i very quickly, enabling him to fully focus on the milling process and deliver top performance.

At the customer's request, the W 250i can be equipped with the Operator Comfort System (OCS) in lieu of the standard operator's platform. The hydraulically moving and swivelling cabin can be adjusted to the ideal position for the operator to have full visibility at all times. Camera transmission, precise joystick control and a powerful automatic climate control system provide a perfect working environment regardless of weather conditions.





1-2 | Control panels with identical features left and right ensure ease of operation.

3 | Optional OCS: the sound-insulated cabin offers good all-round visibility as well as weather protection and air-conditioned interior temperatures.



# Giving operators the full picture - at all times

## JOB PARAMETERS AND CAMERA IMAGES AT A GLANCE

The multifunctional control screen provides clear information on operational parameters and maintenance details. User-friendly diagnostic tools with clear illustrations ensure the transparency of diagnostic procedures. Continuous logging of events during the milling process is yet another useful feature. In addition, the control system displays information such as the weight and volume of the material milled, size of the milled area or number of trucks loaded automatically after manual entry of the material density and milling width. These job data enable easy logging of daily production rates.

The control screen can be switched to camera mode to monitor important work processes. Two or six cameras with high-resolution colour screens can be installed in accordance with customer specifications. When using six cameras, an additional camera screen is installed to allow two camera views to be displayed simultaneously.

The WIRTGEN WITOS FleetView telematics system supports fleet management, machine position and status monitoring, as well as maintenance and diagnostic procedures. In short: it is yet another key driver for improved efficiency in day-to-day operation.

### OVERVIEW OF CAMERAS:

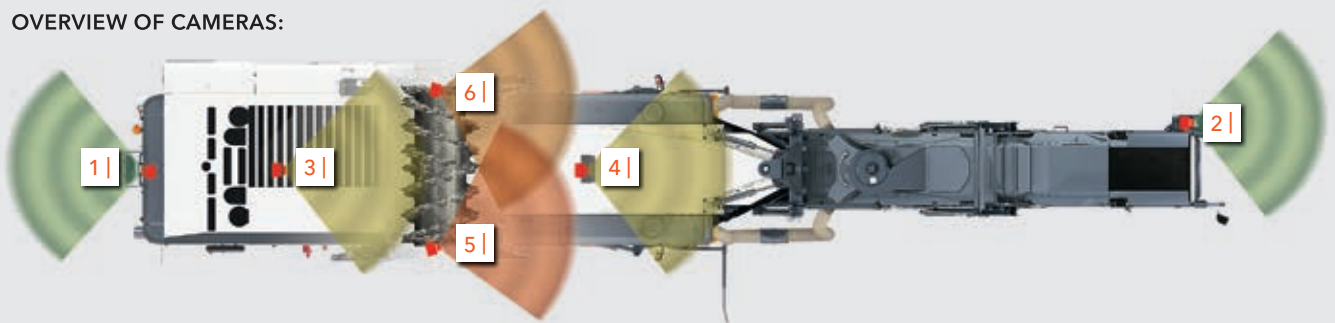

1 | Camera at the rear



2 | Camera at end of conveyor



3 | Camera at scraper



4 | Camera front, centre



5 | Camera front, right



6 | Camera front, left





Operating parameters:



Job data:

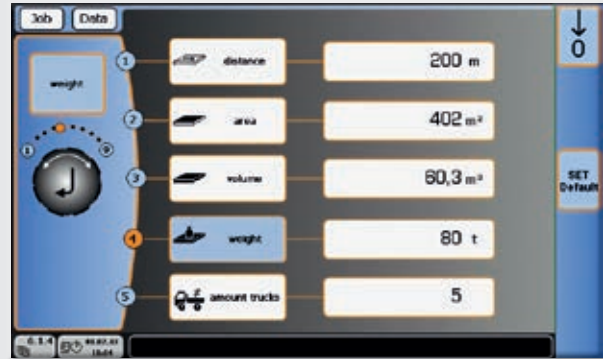

Diagnostics of milling drum unit:

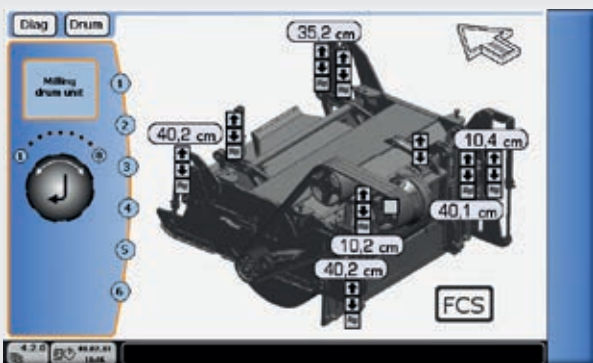

Diagnostics of height adjustment:

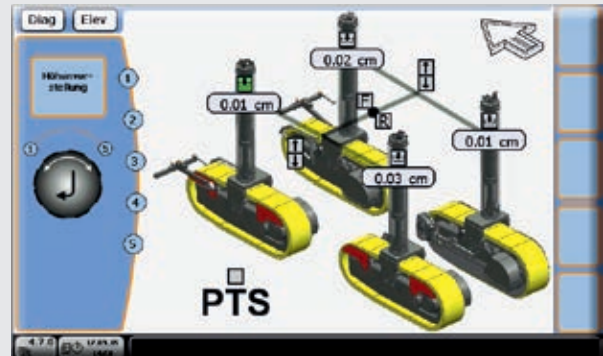



# Perfect visibility and unmatched operator comfort

*Ergonomic working in both upright and seated position.*



## PERFECT WORKING ENVIRONMENT ENSURES MAXIMUM EFFECTIVENESS

The spacious operator's platform is fully equipped to enable ergonomic working in line with practical requirements and over extended periods of time. The recessed machine frame - or so-called "wasp waist" - design of the W 250i provides the machine operator with a full view of the front right track unit, milling edge and side plate. He also has an excellent view, in both upright and seated position, of the controls and everything that is happening on the construction site.

The vibration-isolated operator's platform is accessed conveniently via access ladders mounted on both sides of the machine. It is equipped with individually adjustable comfort seats and a hot-air blower which provide a perfect working environment. Depending on weather and site conditions, the canopy can be extended independently on the left and right.

*Wasp waist design for perfect visibility from the anti-vibration mounted operator's platform; the railing can be moved to the outside.*





# LEVEL PRO - state-of-the-art levelling technology

## PRECISE MILLING RESULTS

WIRTGEN has developed an ultra-precise proprietary levelling system that includes a software programmed specifically for cold milling machines - LEVEL PRO. The overall system comprises the clearly structured LEVEL PRO panel, a controller and multiple sensors. A wide variety of different sensors, such as milling depth, cross slope or ultrasonic sensors, can be integrated into the automatic levelling system. The graphics-enabled LEVEL PRO panel provides a clear readout of key parameters. For example, the set and actual values of two active sensor signals and one passive sensor are continuously displayed on the screens as work progresses. An additional milling depth indicator on the screen - showing the difference between scraper blade and side plate positions - enables convenient monitoring of the actual milling depth. In addition, the memory feature is extremely useful to pre-programme, store and retrieve set values.



### LEVEL PRO SCREEN

Automatic ON/OFF

Settings

Switchover button

Set value

Set value UP/DOWN

Actual value

Calibration

Controller output

Cylinder UP/DOWN

Memory 1

Memory 2









# A new dimension in milling performance.



CLIMB UP. TAKE A DEEP BREATH. START UP THE ENGINE. REGARDLESS OF THE JOB TO BE COMPLETED, YOU DO IT WITH IMPRESSIVE SUPERIORITY, DELIVERING TOP PERFORMANCE. BECAUSE YOU KNOW THAT THE MOST POWERFUL LARGE MILLING MACHINE AVAILABLE FROM THE MARKET LEADER IS IN FULL CONTROL - ALWAYS. OFFERING FLEXIBILITY THANKS TO THE DUAL ENGINE CONCEPT. THE W 250i HAS THE POWER RESERVES IT TAKES TO DELIVER INCREDIBLE MILLING PERFORMANCE.

# Unrivalled power - optimized environmental protection

## STATE-OF-THE-ART ENGINE TECHNOLOGY

Two separate ultra-performance diesel engines enable the W 250i to mobilize unparalleled milling performance whenever required. In addition to the innovative Dual Engine Concept, the large milling machine offers an exceptionally efficient energy balance while keeping the strain on the environment low. For the two economical engines can be operated at three different speed levels to efficiently respond to the specific job requirements. The fully electronic WIDRIVE machine management system enables both engines to always work in the optimum performance and torque ranges, at extremely low fuel consumption rates and low operating costs.

The W 250i features state-of-the-art engine technology for extremely low environmental emission levels, complying with the stringent specifications of exhaust emission standards EC Stage 4/US Tier 4f. To ensure effective exhaust gas purification, one engine is fitted with both a two-way catalytic converter and SCR catalytic converter, while the other engine is fitted with a combined two-way catalytic converter and diesel particulate filter as well as an SCR catalytic converter. Combined with an effective sound insulation of the engine compartment, the quiet ECO engines guarantee low noise emission levels. The operator is protected from vibrations as both engines are supported and isolated from vibration by silent blocks.

W 250i ENGINE CHARACTERISTICS

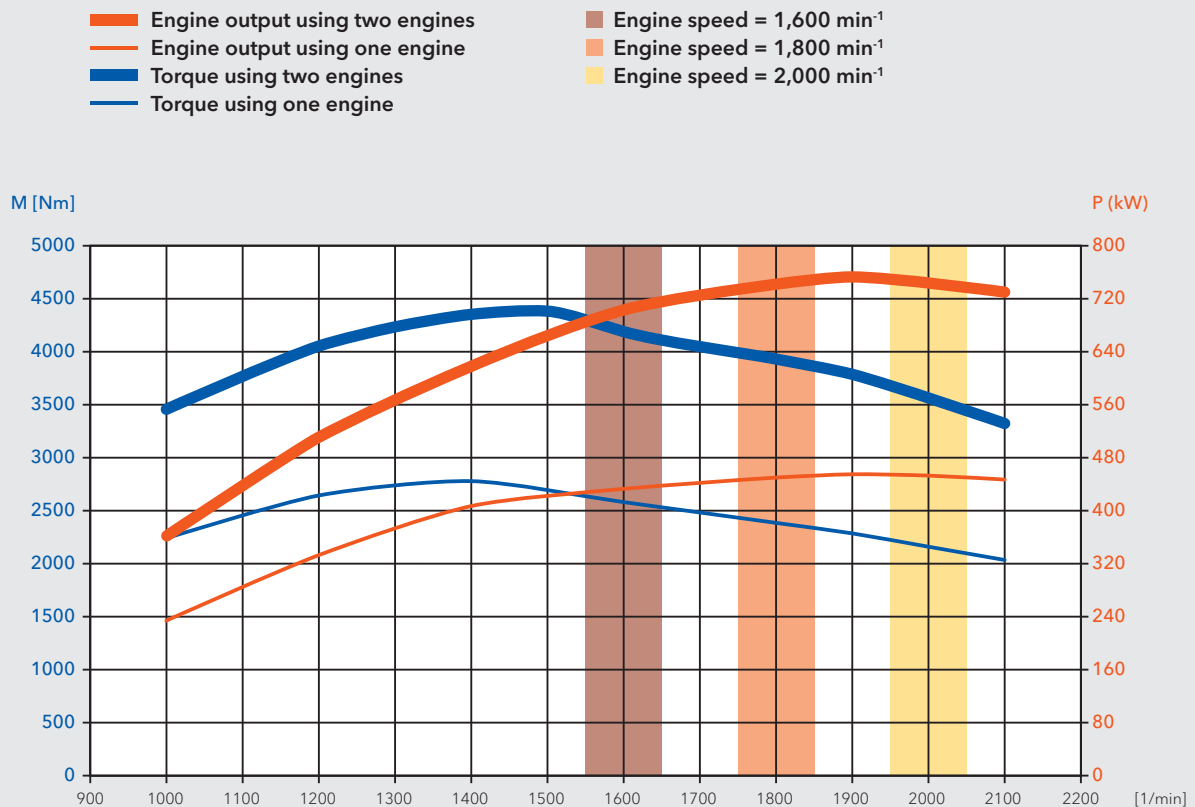



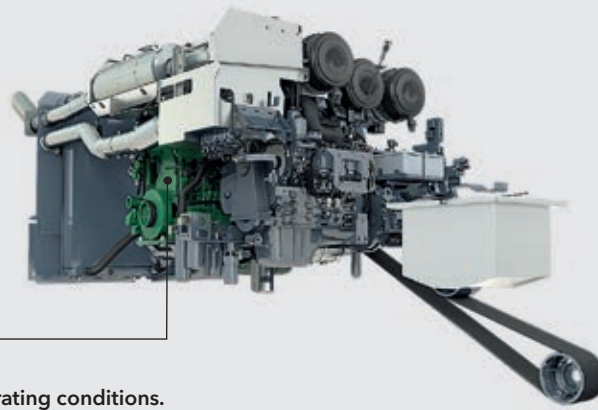

Engine 1

Engine 1 is running in all operating conditions.

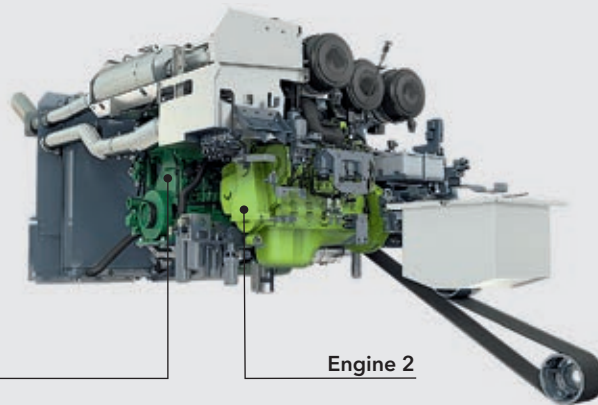

Engine 1

Engine 2

Engine 2 is switched on or off depending on requirements.

# State-of-the-art Dual Engine Concept

## IT TAKES TWO TO BOOST ECONOMIC EFFICIENCY

WIRTGEN is the first cold milling machine manufacturer worldwide to offer uncompromising performance characteristics and maximum efficiency by connecting two diesel engines by means of a multiple V-belt. Taken together, the two engines provide tremendous power, enabling the W 250i to achieve unmatched performance levels. Engine 1 only is in operation in those conditions where the performance level required to achieve the specified results is low. This offers significant advantages: deactivating engine 2 results in lower noise levels, lower fuel consumption and therefore lower exhaust gas emission levels.

While engine 1 drives all functional groups, engine 2 is switched on automatically or at the flick of a switch for full milling power. Engine 2 is switched off automatically in certain situations, for example, when initiating the transport mode or when stopping the traction drive for three minutes or longer. The operator decides for himself whether to switch off engine 2 when performing milling operations at partial load. Operating the machine with engine 1 only is often sufficient when milling off a surface course at a depth of 4 cm.









# Mastering difficult ground conditions.

RESTRICTED SPACE. DIFFICULT GROUND CONDITIONS. PERMANENTLY INSTALLED ROAD FIXTURES. GOOD TO BE PREPARED FOR JUST SUCH A SITUATION. THE W 250i FEATURES INNOVATIVE TECHNOLOGIES HELPING YOU TO REACH YOUR GOAL WITHOUT DELAY. IMPROVED MANOEUVRABILITY, HIGHER ADVANCE RATES, MORE TRACTION. GIVING YOU MORE CONTROL AND MORE PRODUCTIVITY.





*Large steering angles of the four track units enable surprisingly small turning radii.*

## ISC – the intelligent traction drive system

### NARROW RADII, ACCURATE AND FAST STEERING MANOEUVRES

*Crab steering permits the machine to easily approach the milled cut from the side.*

When a large milling machine is required to be highly manoeuvrable or make swift headway on difficult ground, the turn of the W 250i has come. This is, however, attributable not

only to the hydraulic all-track steering system, freely selectable steering modes, track units with separate hydraulic height adjustment or continuously adjustable travel speed.

Add to this the intelligent ISC (Intelligent Speed Control) track control system. It includes three basic features: an electronic traction control system to ensure optimum traction, automatic speed adjustment of the individual track units in bends to reduce track pad wear, as well as an optimized advance rate to ensure maximum milling performance at all times.





# PTS - always parallel to the road surface

## RESPONSIVE SYSTEM LEVELS OUT SURFACE IRREGULARITIES

How come the W 250i always maintains its stability, whether during the milling process, when simultaneously lowering all four lifting columns, when lowering the rear track units into the milling cut, when altering the milling depth, in case of surface irregularities on the left or right side, or when in transport mode? The solution is PTS. The intelligent automatic system aligns the machine parallel to the road pavement: any surface irregularities are levelled out dynamically via the machine's four hydraulically interlinked lifting columns.

This feature provides the W 250i with a high level of stability in both longitudinal and transverse direction, relieves the operator of the need for manual interventions and improves the overall levelling quality. In short - it makes the milling process much more efficient.

*The cold milling machine aligns parallel to the pavement surface automatically.*

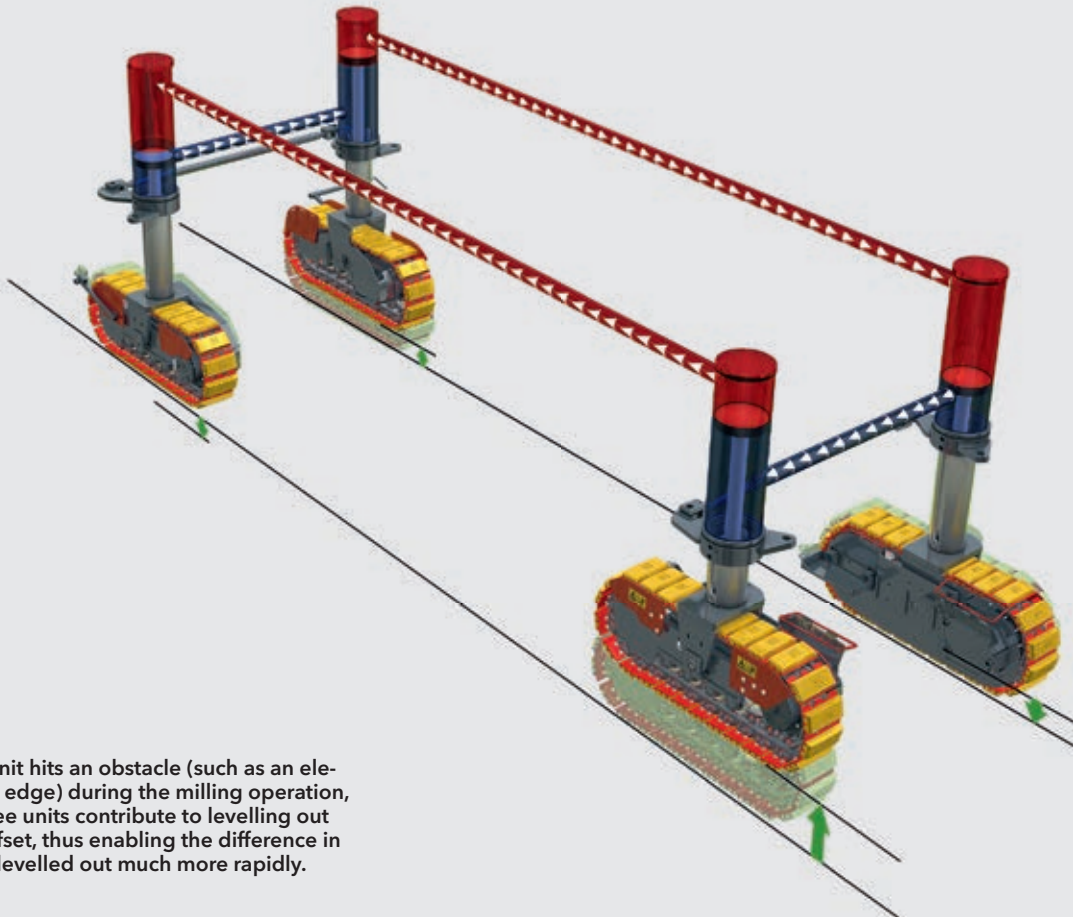

If one track unit hits an obstacle (such as an elevated milling edge) during the milling operation, the other three units contribute to levelling out the height offset, thus enabling the difference in height to be levelled out much more rapidly.



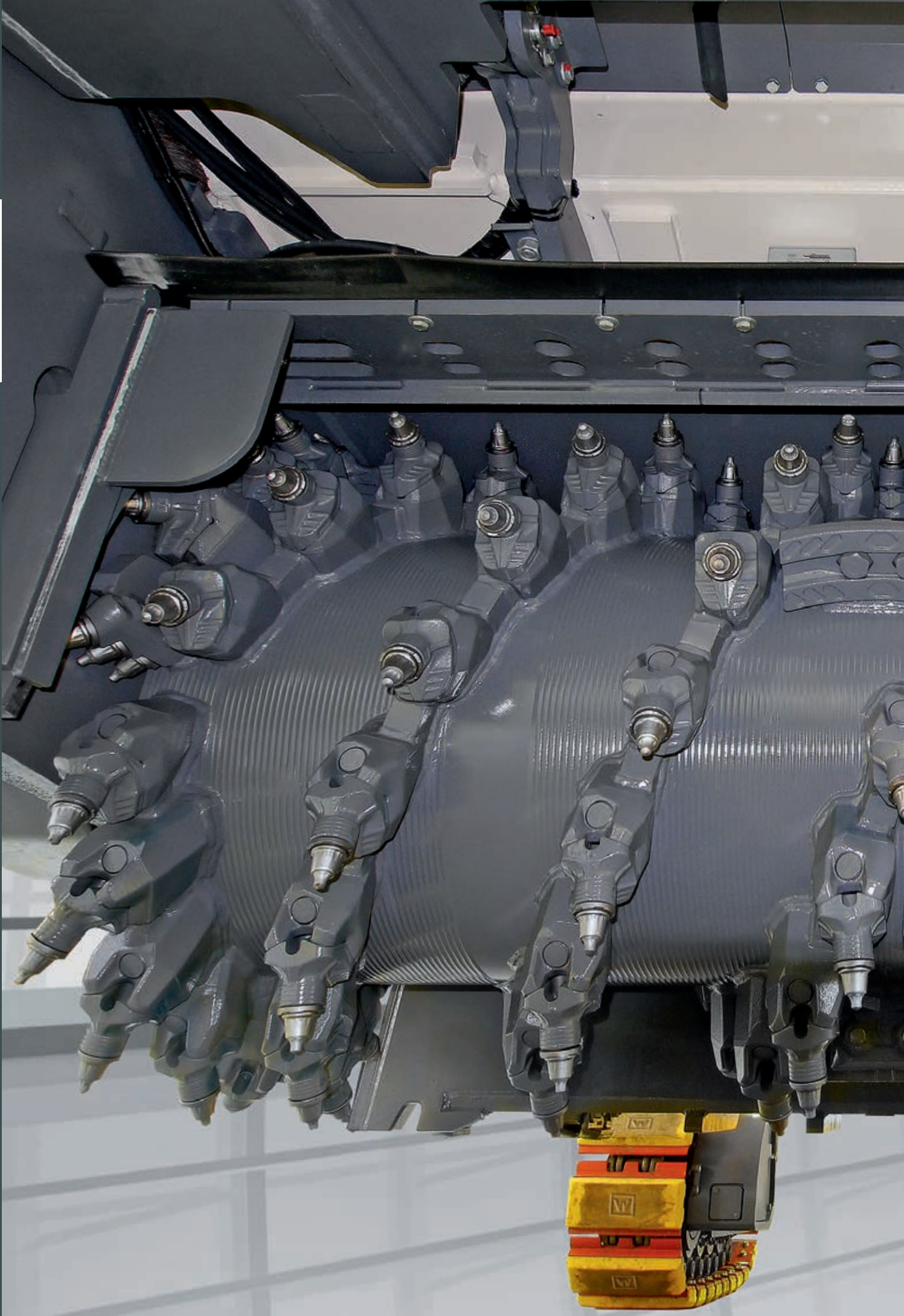





**Heavy-duty design**



**put into practice.**

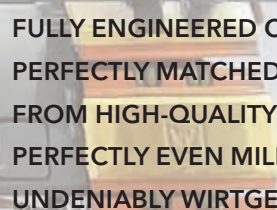

**FULLY ENGINEERED CUTTING TECHNOLOGY - THIS IS WIRTGEN'S CORE EXPERTISE. PERFECTLY MATCHED COMPONENTS MAKE UP THE MILLING DRUM UNIT. MANUFACTURED FROM HIGH-QUALITY MATERIALS, OPTIMIZED IN BOTH FUNCTIONALITY AND DESIGN. FOR PERFECTLY EVEN MILLED SURFACES, EXTENDED SERVICE LIFE AND HIGH PRODUCTIVITY. UNDENIABLY WIRTGEN.**



# HT22 for increased profitability on the job site

## LONG SERVICE LIFE IN EVEN THE TOUGHEST JOBS

*The electrohydraulically operated tool extractor improves the machine's overall productivity.*

The heavy-duty HT22 quick-change tool-holder system minimizes breaks in operation as it has been designed for tough operating conditions.

This is ensured by the use of exceptionally wear-resistant materials, perfect tool rotation and easy tool replacement - to name just a few of its many advantages. Cutting tool replacement can be facilitated further by means of a hydraulic drum turning device and an additional seat mounted between the rear track units.

The cutting tools are replaced using either standard manual or pneumatic extractors or - to optimize the process - an electrohydraulic tool extractor which extracts the tools effortlessly with the engine switched off.



## HT22 QUICK-CHANGE TOOLHOLDER SYSTEM IN DETAIL

- 1 | Extremely large maximum wear distance
- 2 | Wear markers at 5 mm intervals
- 3 | High wear volume
- 4 | Optimized shank angle geometry for high component strength
- 5 | Large shank cross-section for significantly higher fracture strength
- 6 | Protective plug prevents soiling of bolt head
- 7 | Heavy-duty retaining bolt
- 8 | Seal between upper part and bottom part to allow simple insertion/removal of upper part
- 9 | Upper part covers bottom part completely for full protection of bottom part
- 10 | Extra large contact surface between upper part and bottom part for extended bottom part life
- 11 | Optimized welded connection offering increased strength and simultaneous flexibility for optimum tool rotation

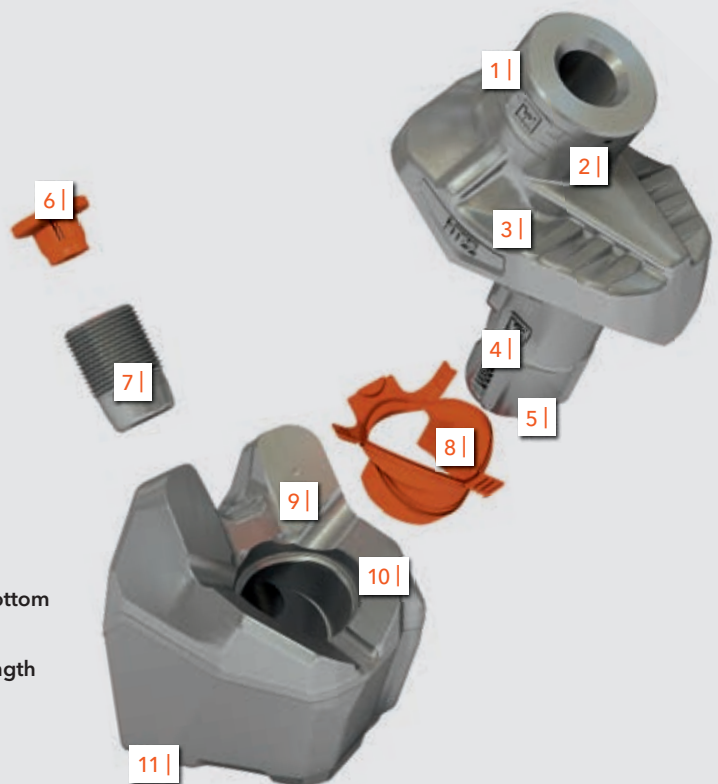

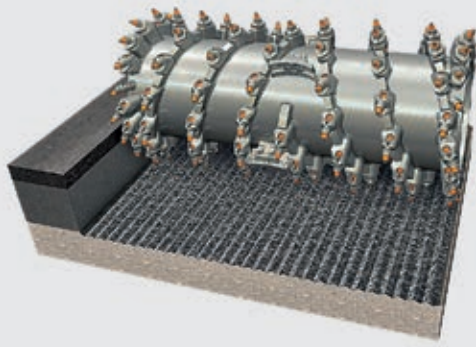

**ECO cutter**

Milling width: 2.2 m  
 Milling depth: 0-350 mm  
 Tool spacing: 25 mm

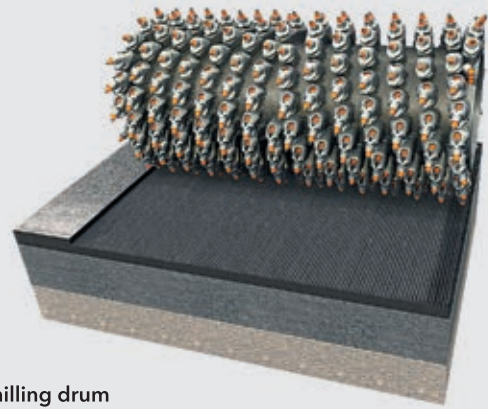

**Fine milling drum**

Milling width: 2.2 m  
 Milling depth: 0-100 mm  
 Tool spacing: 8 mm

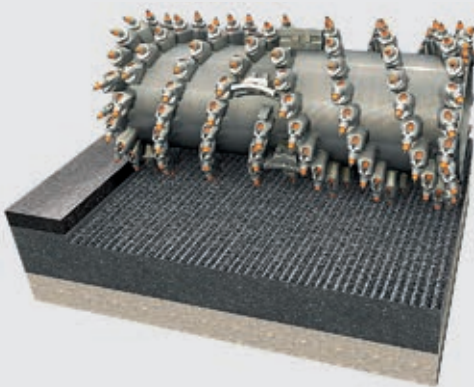

**Standard milling drum**

Milling width: 2.2 m  
 Milling depth: 0-350 mm  
 Tool spacing: 15 mm

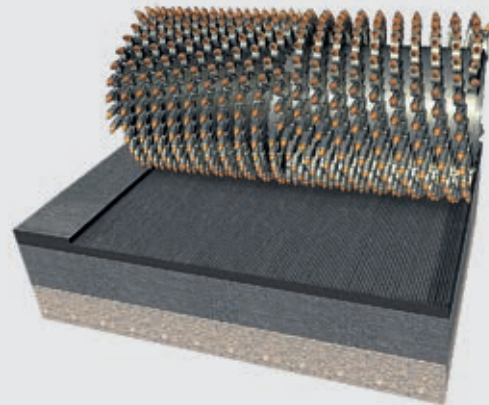

**Micro-fine milling drum**

Milling width: 2.2 m  
 Milling depth: 0-30 mm  
 Tool spacing: 6 x 2 mm

# 2.2 m drum assembly with FCS Light

## WIDE RANGE OF APPLICATIONS

ECO cutters fitted with a reduced number of point-attack cutting tools ensure maximum area performance. Standard milling drums are ideally suited to the removal of one or more pavement layers, ensuring a good interlock between the milled surface and the new pavement.

Fine milling drums create finely textured surfaces ideally suited as a base for the application of thin pavement layers. Micro-fine milling drums are used to roughen road pavements and to improve their evenness and skid resistance.





# Wide range of applications with milling widths from 2.20 m to 4.40 m

30  
31

## COST AND QUALITY BENEFITS THROUGH XXL-SIZE MILLING DRUM UNITS

*The giant drum units achieve optimum results when milling off layers at depths of up to 10 cm.*

To fully exploit its tremendous milling potential, a housing extension enables the W 250i to be equipped with milling drums of up to 4.40 m in width. Milling drum units wider than 2.20 m pay for themselves quickly through

tremendous area performance as they enable wide road pavements to be removed in a single machine pass.

The oversized milling drum units play their trump cards in particular on wide urban roads, motorways, highways and airports, impressing with perfectly even milled surfaces. They offer a tremendous saving potential as a process using larger milling widths reduces the number of adjacent cuts and of the turning manoeuvres required while at the same time driving down labour cost.



Six different milling width options on offer:



W 250i with 2.2-m drum assembly



W 250i with 2.5-m drum assembly



W 250i with 3.8-m drum assembly

The following are additionally available:

- > Drum assembly with a working width of 3.1 m
- > Drum assembly with a working width of 3.5 m
- > Drum assembly with a working width of 4.4 m









*The left side plate can be raised by 350 mm, the right one by as much as 450 mm.*

## Milling drum unit with many useful features

### **MILLING FLUSH TO KERB RIGHT DOWN TO THE FULL WORKING DEPTH**

An intelligently designed milling drum unit is part of the W 250i's standard equipment package. For full loading of the milled material, the operator lowers the scraper blade hydraulically. When raised and locked at the required height, the scraper blade enables the milled material to either be partially loaded or remain in the milled cut. In addition, the scraper blade can be swung wide open for the replacement of cutting tools. To prevent any collisions occurring during manoeuvring, the gradation control beam, scraper blade and side plates are moved into a protective

position when in transport mode. Yet another extra feature: in emergency mode, all cylinder functions can be operated even with the engine switched off.

Yet another highlight: the side plate on the right can be raised by as much as 450 mm. Accurate milling flush to kerb is thus also ensured at large working depths, enabling the side plate to move over the kerb for the purpose of level detection.





3 | Dimensions in mm:

1 | Set the scraper blade to "floating" position to allow full loading of the milled material.

2 | Lock the scraper blade at the required height for partial loading of the milled material.

3 | Accurate milling along kerbs is possible on the right side even at maximum milling depth.











# Loading huge amounts of material.

THE LARGEST WIRTGEN COLD MILLING MACHINE IS EXPECTED TO DELIVER TOP PERFORMANCE CONTINUOUSLY AND IN EVERY REGARD. MATERIAL LOADING INCLUDED. THE CONVEYOR INSTALLED IN THE W 250i IS READY TO TAKE ON EVERY CHALLENGE. THANKS TO COMPONENTS OF EXTRA STURDY DESIGN. WITH APPLICATION-SPECIFIC FLEXIBILITY COMING AS A STANDARD FEATURE. COMBINING PIONEERING POWER AND TECHNOLOGY.



# Removing many tonnes of milled material

1 | Wide conveyor slewing angles of 60° to either side ensure smooth material transport.

2 | Useful for night work: the stoplight system gives silent "Stop" and "Go" instructions to the truck driver.





## RELIABLE MATERIAL LOADING EVEN UNDER FULL LOAD

The extremely powerful W 250i has been designed for maximum performance and is therefore equipped with a conveyor system offering exceptionally high conveying capacities. The discharge conveyor can be adjusted in height and slewed to either side, thus enabling tremendous amounts of milled material to be loaded onto trucks in a flexible and cost-effective process.

This is of advantage in particular when working in narrow bends or crossroad areas and to ensure that trucks can change "on the fly".

The conveyor system can be continuously adjusted to different belt speeds as required by the milling job. Optimizing the belt speed guarantees minimum wear of the belts which feature rugged cleat profiles. Wear of the primary conveyor is minimized as the belt speed is controlled automatically in accordance with the load.

*Continuously adjustable belt speed and discharge range.*

-  High belt speed
-  Low belt speed





# VCS - Vacuum Cutting System offers a perfect working environment

## INNOVATIVE EXTRACTION TECHNOLOGY FOR AN UNOBSTRUCTED VIEW OF THE MILLING EDGE

The health and well-being of the operating crew deserve particular attention. The W 250i can therefore be equipped with the Vacuum Cutting System to extract fine material particles: by creating a negative pressure in the milling drum housing, the mix of air and water vapour is evacuated from the housing and then fed back into the stream of the milled material on the discharge conveyor via a hose system.

Better air quality and visibility in the working environment of the machine operator and ground crew significantly improve operator comfort and boost staff performance. In addition, reduced soiling of components such as the engine or air filter results in savings in the replacement of spare parts or cleaning of the machine.



*The centrifugal fan can be adjusted in speed.*

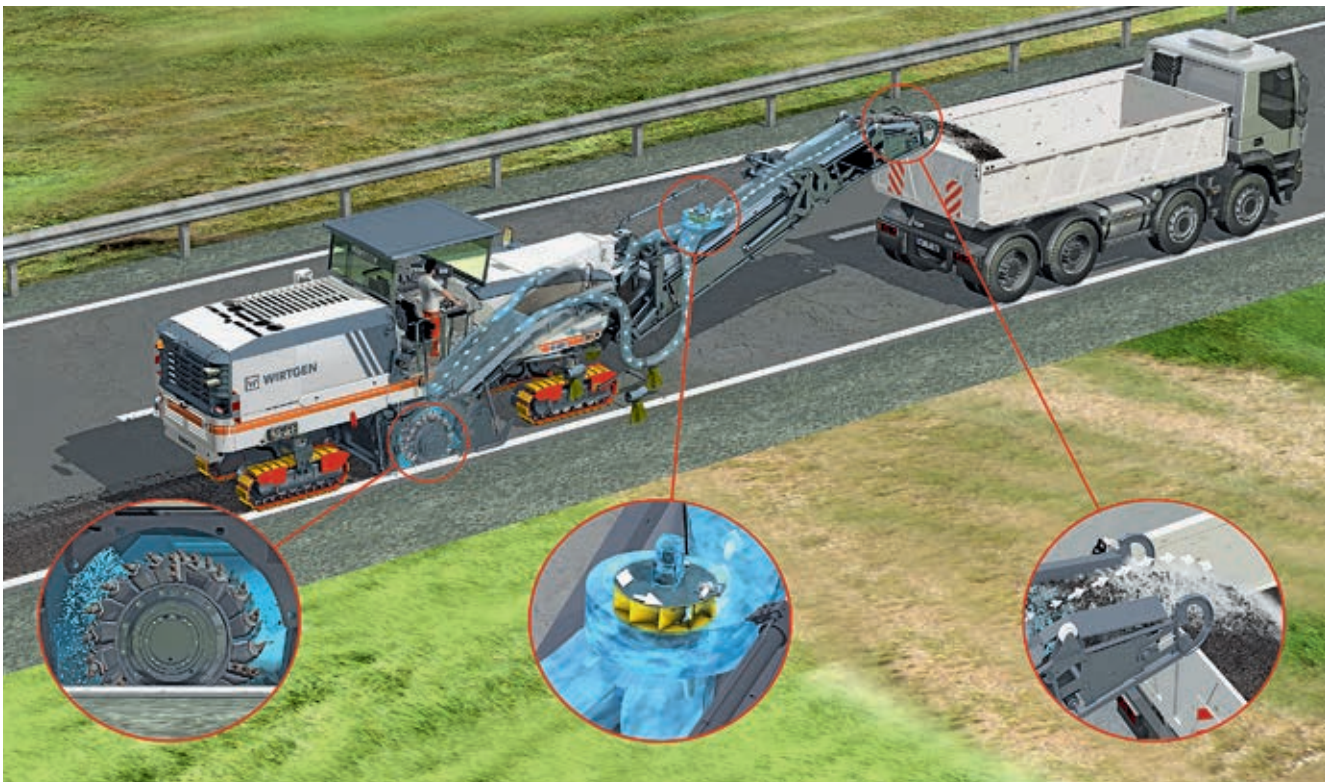







Ready to deliver

full performance - always.



NO TWO MILLING JOBS ARE ALIKE. UNCHANGING, HOWEVER: FULL OPERATIONAL READINESS OF THE W 250i. ENSURED BY THE MACHINE'S HEAVY-DUTY DESIGN AND EFFECTIVE LIGHTING SYSTEM, EASE OF MAINTENANCE AND EXTENDED SERVICING INTERVALS. FOR NOTHING IS MORE IMPORTANT TO US THAN ENSURING THE OPERATIONAL AVAILABILITY OF YOUR COLD MILLING MACHINE.





*The engine cowling opens hydraulically at the mere push of a button.*

## Quick maintenance boosts productivity

### FOR PEACE OF MIND IN OPERATION

The hydraulically opening, hinged engine cowling and wide-opening service panels on either side ensure full access to all components requiring maintenance. All points of maintenance have been grouped together

and are arranged in a clear pattern, offering convenient access. The machine's automatic diagnostic system autonomously monitors valves, sensors and control components. Ample space is available for storing spare cutting tools, tool kit, machine equipment and high-pressure cleaner.

*Excellent lighting enables night operations to be completed quickly and efficiently.*

### SUCCESSFUL MOVES IN NIGHT OPERATION

The lighting system comprises several working lights and LED lamps offering flexible adjustment options to fully illuminate the important work areas. Backlit control panels enable the machine operator to easily control the W 250i even during night operations.





# Heavy transport made easy

## TRANSPORT - A SMOOTH AFFAIR

The folding conveyor design reduces the overall length of the W 250i, thus permitting the use of smaller transport vehicles. The canopy is folded down hydraulically at the mere push of a button.

Flexible supplementary weights enable transport of the W 250i on vehicles with a low maximum permissible payload.

Strong loading and lashing lugs enable the machine to be safely lashed down on a trailer or loaded by crane. Our range of equipment options includes conveyor support legs for machine transport on a flatbed truck.

*The folding conveyor reduces the machine's transport length.*

*Transport on a flatbed truck with the canopy folded down - tailored to accurate fit!*







THE W 250i SUCCESSFULLY MASTERS YET ANOTHER MAJOR CHALLENGE: COMPLYING WITH EVER STRICTER ENVIRONMENTAL STANDARDS. THE LARGE MILLING MACHINE REDUCES ENVIRONMENTAL EMISSION LEVELS SIGNIFICANTLY WITH ITS INTELLIGENT WIDRIVE MACHINE MANAGEMENT SYSTEM, INNOVATIVE VCS DUST EXTRACTION SYSTEM AND DUAL ENGINE CONCEPT.



**State-of-the-art machine technology**

**for a clean environment.**





# Technical specification

Milling drum	
Milling width	2,200 mm
Milling depth * <sup>1</sup>	0-350 mm
Drum diameter with tools	1,140 mm
Motor	
Engine	CUMMINS
Type	QSX 15 + QSL 9
Cooling	water
Number of cylinders	6 + 6
Rated power at 2,100 min <sup>-1</sup>	730 kW/979 HP/993 PS
Maximum power at 1,900 min <sup>-1</sup>	753 kW/1,010 HP/1,024 PS
Displacement	24 l
Fuel consumption at rated power	191 l/h
Fuel consumption in field mix	76 l/h
Emission standards	EC Stage 4 / US Tier 4f
Electrical system	
Electrical power supply	24 V
Tank capacities	
Fuel tank	1,360 l
AdBlue®/DEF tank	100 l
Hydraulic oil tank	300 l
Water tank	4,850 l
Driving properties	
Max. travel and milling speed	0-88 m/min (5.3 km/h)
Track units	
Track units, front and rear (L x W x H)	1,330 x 260 x 550 mm
Loading of the milled material	
Belt width of primary conveyor	1,100 mm
Belt width of discharge conveyor	1,100 mm
Theoretical capacity of discharge conveyor	668 m <sup>3</sup> /h

\*<sup>1</sup> = The maximum milling depth may deviate from the value indicated due to tolerances and wear.



<b>Weight of base machine</b>	
Empty weight of machine excluding tank contents	40,900 kg
Operating weight, CE* <sup>2</sup>	44,050 kg
Maximum operating weight (full tanks, full range of equipment) in FB2200	51,100 kg
<b>Weights of tank contents</b>	
Water tank filling	4,850 kg
Diesel tank filling (0.83 kg/l)	1,129 kg
AdBlue®/DEF tank filling (1.1 kg/l)	110 kg
<b>Additional add-on weights</b>	
<b>Driver and tools</b>	
Driver	75 kg
5 cutting tool containers	125 kg
On-board tools	30 kg
<b>Optional milling drum assemblies in lieu of standard</b>	
Milling drum housing FB2200 FCS-L	690 kg
Milling drum housing FB2500 FCS	550 kg
Milling drum housing FB3100 FCS	1,400 kg
Milling drum housing FB3500 FCS	3,500 kg
Milling drum housing FB3800 FCS	4,140 kg
Milling drum housing FB4400 FCS	5,400 kg
<b>Optional FCS milling drums in lieu of standard</b>	
Milling drum FB2200 HT22 LA15 FCS-L with 188 picks	- 120 kg
Milling drum FB2200 HT22 LA18 FCS-L with 164 picks	- 320 kg
Milling drum FB2500 HT22 LA15 FCS with 211 picks	850 kg
Milling drum FB3100 HT22 LA15 FCS with 267 picks	1,030 kg
Milling drum FB3500 HT22 LA15 FCS with 294 picks	2,020 kg
Milling drum FB3800 HT22 LA15 FCS with 314 picks	2,450 kg
Milling drum FB4400 HT22 LA15 FCS with 353 picks	3,010 kg
Milling drum FB2200 HT22 LA8 FCS with 298 picks	380 kg
Milling drum FB2200 HT22 LA25 FCS-L with 134 picks	- 630 kg
Milling drum FB2200 HT5 LA6X2 FCS-L with 740 picks	410 kg
<b>Optional additional equipment</b>	
Canopy in lieu of standard	270 kg
Folding conveyor in lieu of standard	600 kg
Operator's platform including comfortable seats in lieu of standard	250 kg
Supplementary weight for flexible use	1,500 kg

\*<sup>2</sup> = Weight of machine, half-full water tank, half-full fuel tank, driver (75 kg), on-board tools, excluding optional equipment features.



# Dimensions

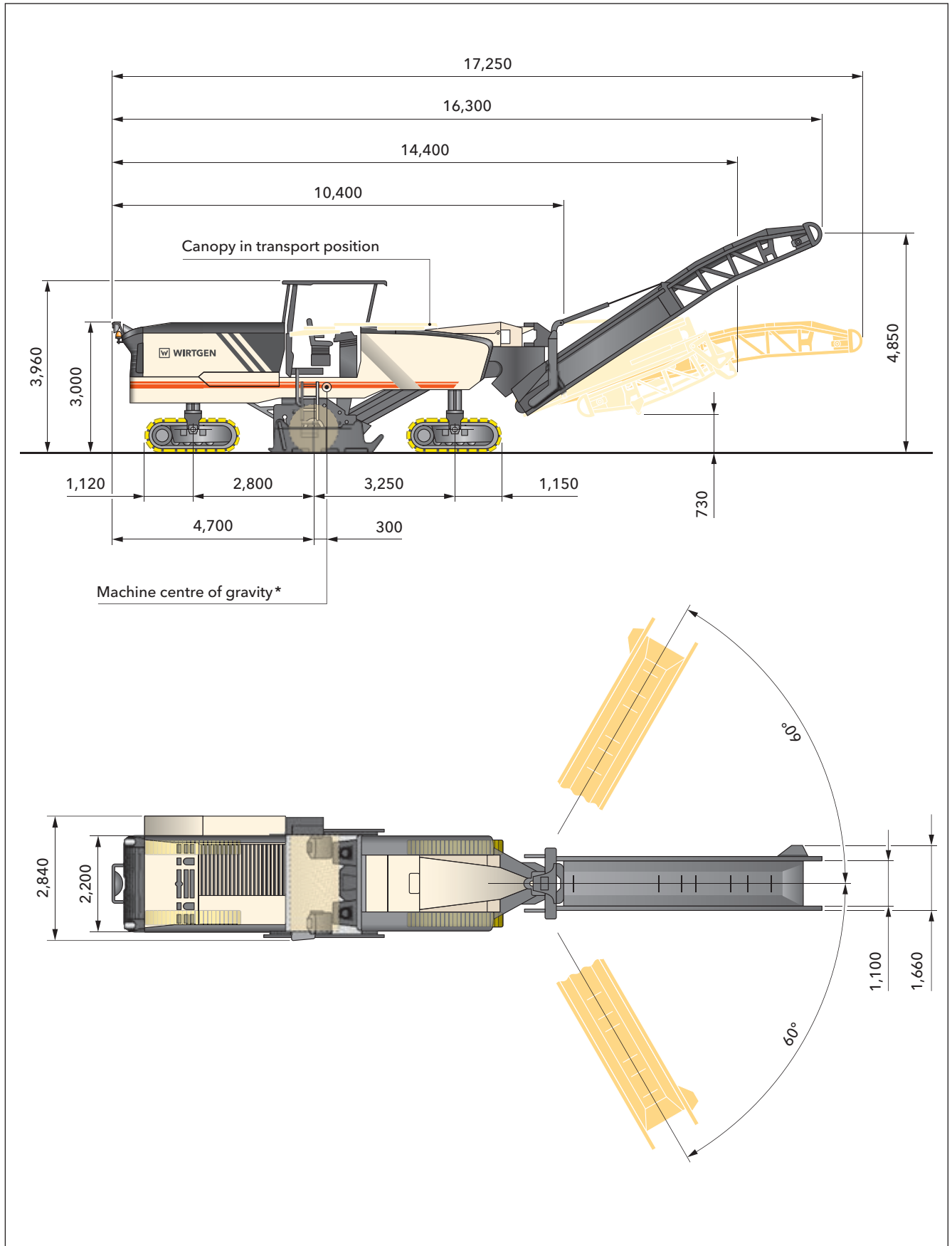

Dimensions in mm

\*Based on operating weight, CE with conveyor folded out



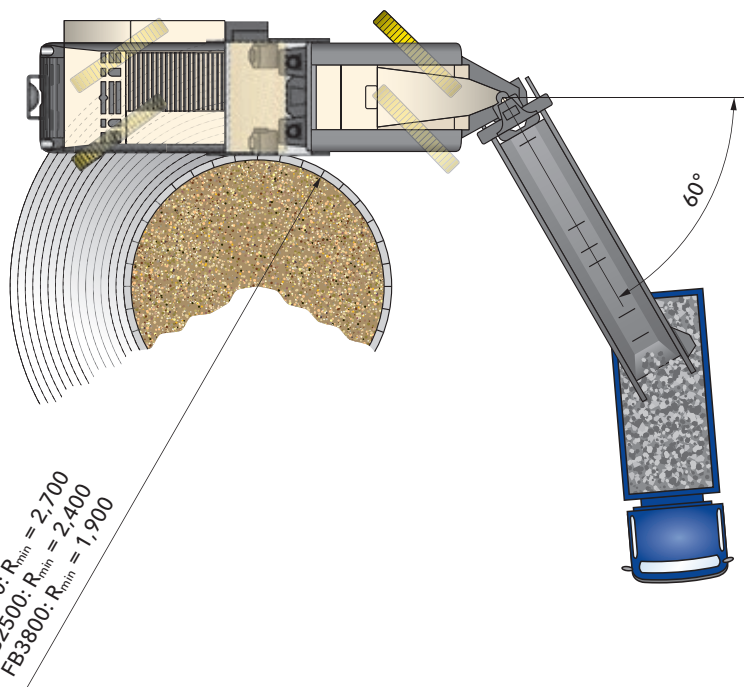
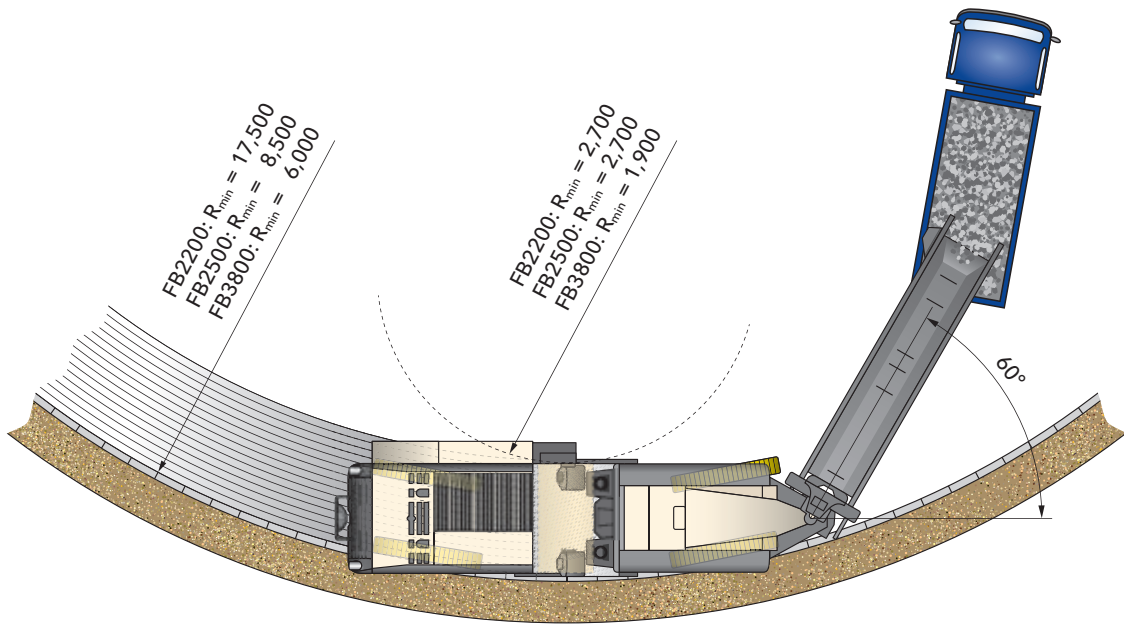

Milling radius, milling depth 150 mm, Dimensions in mm



# Standard equipment

Base machine	
Basic machine with engine	■
Maschine chassis with double-sided wasp waist	■
Hydraulically opening engine cover with noise insulation	■
Air compressor system	■
Battery operated hydraulic unit for emergency functions	■
Cooling system with temperature-controlled fan speed	■
Large storage compartments for pick buckets	■
Milling drum unit	
Three milling drum rotation speeds with electric on/off function 105 r.p.m. - 94 r.p.m. - 84 r.p.m.	■
Hydraulic material depressor with conveyor lifting function	■
Hydraulically movable and positionable scraper plate with automatic locking	■
Hydraulically lifting side plate, right clearance 450 mm and left clearance 350 mm	■
Two water sprinkling strips in the milling drum unit with separate on/off function	■
Milling drum housing FB2200	□
Milling drums	
Milling drum FB2200 HT22 LA15 with 188 picks	□
Milled-out material loading	
Conveyor belt system with manually or automatically controllable transport speed	■
Water sprinkling system in the primary conveyor	■
Slewing angle discharge conveyor $\pm 60^\circ$	■
Discharge conveyor, 8,150 mm long, 1,100 mm wide, with hydraulic folding device	□
Machine control and levelling system	
Multi-function control display showing important machine operating conditions	■
Extensive machine diagnosis in the control display	■
Milling power control with automatic on/off function	■
Two exterior panels for operating functions by ground personnel	■
Milling depth regulation with LEVEL PRO levelling system, with one operating display as well as one electrical height sensor in the hydraulic cylinders right and left on side plate	■

- = Standard equipment
- = Standard equipment, replaceable with optional equipment
- = Optional equipment



Operator's stand	
Operator's stand with complete flexible mounting	■
Convenient, individually adjustable operating panel	■
Convenient footstep to the operator's stand, right and left	■
Covers for operating panels with lock	■
Two mirrors front, one mirror middle and one mirror in rear area of the machine	■
Operator's stand with single standing seats	□
Exterior mirror standard	□
Under-carriage and height adjustment	
PTS - machine automatically guided parallel with the road surface	■
ISC - intelligent track speed control with hydraulic four chain drive	■
High machine stability due to quadruple pendulum axle	■
Freely selectable steering functions for the four-track steering	■
Extremely wear-resistant, two-piece EPS-plus polyurethane track pads	■
Others	
Lighting package with 3 halogen floodlights and 4 LED lights in the area of the milling unit	■
"Welcome" and "Go home" lights feature including LED lighting in the area of the operator's access and platform	■
Large tool package in lockable tool box	■
Total of 6 EMERGENCY STOP switches at sensible positions on the machine	■
Water high-pressure system with automatic on/off function, 18 bar, 67 l/min	■
Machine preparation for installing the control unit for WITOS FleetView. "WIRTGEN Road Technologies Telematics and on-site Solutions" (WITOS) is the intelligent telematics system of the WIRTGEN Road Technologies for efficient fleet and service management worldwide.	■
European type test certificate, Euro Test-mark and CE conformity	■
Water tank filling from rear of machine	□
Paint standard cream white RAL 9001	□
Halogen lighting package 24 V with rotary beacons	□

- = Standard equipment
- = Standard equipment, replaceable with optional equipment
- = Optional equipment

# Optional equipment

Milling drum unit	
Milling drum housing FB2200 FCS-L	<input type="checkbox"/>
Milling drum housing FB2500 FCS	<input type="checkbox"/>
Milling drum housing FB3100 FCS	<input type="checkbox"/>
Milling drum housing FB3500 FCS	<input type="checkbox"/>
Milling drum housing FB3800 FCS	<input type="checkbox"/>
Milling drum housing FB4400 FCS	<input type="checkbox"/>
Transport carriage for milling drum units from FB2200 to FB4400	<input type="checkbox"/>
Transport carriage for FCS milling drums from FB2000 to FB2200	<input type="checkbox"/>
Milling drums	
Milling drum FB2200 HT22 LA15 FCS with 188 picks	<input type="checkbox"/>
Milling drum FB2200 HT22 LA18 FCS with 164 picks	<input type="checkbox"/>
Milling drum FB2200 HT22 LA15 FCS multi-piece with 188 picks	<input type="checkbox"/>
Milling drum FB2500 HT22 LA15 FCS multi-piece with 211 picks	<input type="checkbox"/>
Milling drum FB3100 HT22 LA15 FCS multi-piece with 267 picks	<input type="checkbox"/>
Milling drum FB3500 HT22 LA15 FCS multi-piece with 294 picks	<input type="checkbox"/>
Milling drum FB3800 HT22 LA15 FCS multi-piece with 314 picks	<input type="checkbox"/>
Milling drum FB4400 HT22 LA15 FCS multi-piece with 353 picks	<input type="checkbox"/>
Milling drum FB2200 HT22 LA8 FCS with 298 picks	<input type="checkbox"/>
Milling drum FB2200 HT22 LA25 FCS with 134 picks	<input type="checkbox"/>
Milling drum FB2200 HT5 LA6X2 FCS with 740 picks	<input type="checkbox"/>
Milled-out material loading	
Double discharge conveyor, 8,150 mm long, 1,100 mm wide, with hydraulic folding device	<input type="checkbox"/>
VCS extraction system	<input type="checkbox"/>
VCS extraction system on the double discharge conveyor	<input type="checkbox"/>
Supporting device discharge conveyor	<input type="checkbox"/>
Machine control and levelling system	
Sonic Ski sensor with connection cable	<input type="checkbox"/>
Levelling boom for scanning up to 4 m to the side of the machine	<input type="checkbox"/>
Hydraulic sensor for scanning ahead of the milling drum right	<input type="checkbox"/>
Hydraulic sensor for scanning ahead of the milling drum right + left	<input type="checkbox"/>
Operating display LEVEL PRO	<input type="checkbox"/>
Multiplex preliminary equipment comprising 4 sensor sockets	<input type="checkbox"/>
Multiplex 3-way right with 2 ultrasonic sensors, including Multiplex preliminary equipment	<input type="checkbox"/>
Multiplex 3-way right + left with 4 ultrasonic sensors, including Multiplex preliminary equipment	<input type="checkbox"/>
Basic equipment laser levelling without laser transmitter	<input type="checkbox"/>
Level control 3D levelling pre-equipment	<input type="checkbox"/>
Slope control sensor	<input type="checkbox"/>

- = Standard equipment
- = Standard equipment, replaceable with optional equipment
- = Optional equipment



Operator's stand	
Operator's stand with large storage compartment and single standing seats	<input type="checkbox"/>
Operator's stand with comfort seat package	<input type="checkbox"/>
Operator's stand with cabin "Operator Comfort System"	<input type="checkbox"/>
Exterior mirror folding with signal lights	<input type="checkbox"/>
Weather canopy folds in electrohydraulically	<input type="checkbox"/>
Hot air heating footwell of the operator's stand	<input type="checkbox"/>
Monitor system with 2 cameras	<input type="checkbox"/>
Monitor system with 6 cameras and additional monitor	<input type="checkbox"/>
Others	
Water tank filling with hydraulic filling pump	<input type="checkbox"/>
Paint in one special colour (RAL)	<input type="checkbox"/>
Paint in two special colours (RAL)	<input type="checkbox"/>
Paint in maximum two special colours with substructure in special colour (RAL)	<input type="checkbox"/>
Powerful LED lighting package 24 V with rotary beacons	<input type="checkbox"/>
Additional weight 1,500 kg	<input type="checkbox"/>
Large storage compartment on rear of machine	<input type="checkbox"/>
Electric preheating of the fuel filter	<input type="checkbox"/>
Electrical power set 220 V 4 kW	<input type="checkbox"/>
High-pressure water cleaner, 150 bar 15 l/min	<input type="checkbox"/>
Milling drum rotation device	<input type="checkbox"/>
Milling drum rotation device XXL milling unit	<input type="checkbox"/>
Hydraulic pick ejector drift	<input type="checkbox"/>
Pneumatic hammer with pick ejector / inserter	<input type="checkbox"/>
Additional seats for pick change with storage compartment	<input type="checkbox"/>
Diesel tank filling pump with 5.00 m suction hose	<input type="checkbox"/>
Illumination balloon 220 volt	<input type="checkbox"/>
Illumination balloon 110 volt	<input type="checkbox"/>
WITOS FleetView telematics system incl. 3-year operating period (EU)	<input type="checkbox"/>
Maintenance fee WITOS FleetView for one subsequent year	<input type="checkbox"/>
WITOS FleetView telematics system incl. 3-year operating period (USA)	<input type="checkbox"/>
WITOS FleetView telematics system incl. 3-year operating period - PROMOTION	<input type="checkbox"/>

= Standard equipment  
 = Standard equipment, replaceable with optional equipment  
 = Optional equipment



WIRTGEN GmbH  
Reinhard-Wirtgen-Str. 2 · 53578 Windhagen · Germany  
Phone: +49 (0)26 45/131-0 · Fax: +49 (0)26 45/131-392  
Internet: [www.wirtgen.com](http://www.wirtgen.com) · E-Mail: [info@wirtgen.com](mailto:info@wirtgen.com)

