

G-SERIES
FORWARDERS



JOHN DEERE

910G / 1010G / 1110G / 1210G / 1510G / 1910G



**WORK SMARTER
AND HARDER**



MOVING

A large logging machine, possibly a skidder or grapple loader, is shown in a dense forest. The machine's long, black hydraulic arm extends from the left side of the frame, ending in a yellow grapple. The grapple is positioned over a large log lying on the ground. The forest consists of many tall, thin trees, and the ground is covered with green undergrowth and fallen leaves. The lighting is bright, suggesting a sunny day.

KEEP PRODUCTIVITY
IG FORWARD.

We've put some serious thought into our G-Series Forwarders.

But the real brainpower behind our latest models is you. Through our Customer Advocate Group (CAG), we collected invaluable input from loggers just like you — the ones who live it every day. Then we spent thousands of hours testing the machines until we got them exactly right.

These forward-thinking forwarders are loaded with improvements that boost performance and long-term durability, including increased power and torque. An upgraded Intelligent Boom Control (IBC) system option for more precise boom control. And, as always, a host of enhancements that help deliver more uptime and efficiency, while lowering daily operating costs.

Built on more than 180 years of groundbreaking innovation. Backed by over a half-century of experience in the woods. And designed with proven components to withstand the toughest environments. The G-Series will make you rethink what a forwarder can accomplish for your operation.

WON'T LET UP — OR LET YOU DOWN

Lower the boom on downtime.

When you work in remote areas, downtime is never an option. G-Series Forwarders are built forest-tough, with durable booms, axles, and electrical components.

Dependable booms

Optional IBC system features sensors that dampen boom movements, protecting boom structures, for longer life.

Robust axles

Duraxle™ heavy-duty (HD) bogie axles — available in the 1210G, 1510G, and 1910G — are designed to carry hefty loads over long distances. Robust axles together with increased diesel power deliver solid tractive performance in every operating condition.

Tough brakes

Hydraulically actuated, oil-immersed, multi-disc service brakes provide dependable stopping power.

Simplified electrical system

More reliable electrical architecture simplifies wiring harnesses and minimizes the number of fuses, relays, and electrical connectors.



CUT-TO-LENGTH EQUIPMENT

Choose to do more.

Our full line of forestry equipment features a wide range of forwarder models — including the new 910G and 1010G — designed to fit the way you work, no matter where in the woods your work takes you.

New 910G and 1010G

Ideal for early to late thinning operations, the compact dimensions of our latest models maximize productivity and power in the most demanding conditions.

Short-wheelbase 1110G

The 1110G Forwarder is also available with a 40-cm-shorter wheelbase, for better agility in thinnings, without compromising stability or load size.

More agile 1510G

Boasting an increased slewing angle, the 1510G Forwarder is more nimble than previous models.

Long-bogie models

Available for the 1010G, 1110G, 1210G, and 1510G, long-bogie versions deliver lower ground pressure than standard bogie models, for logging in soft terrain. They also improve the sideways stability of the rear frame while driving.

Mammoth 1910G

The larger transmission pump and motor of the 1910G power greater tractive force.



**SHORT FRAME ON 910G AND 1010G
EASES TRAVEL IN
UNEVEN TERRAIN**







EXPERIENCE A BOOM IN PRODUCTIVITY Intelligent Boom Control.

Optional Intelligent Boom Control (IBC) on G-Series Forwarders eases boom operations, making them more precise and productive.

More productive from the get-go

IBC boosts boom efficiency to help increase operator productivity.

More precise grapple positioning

IBC improves the precision of grapple positioning, especially with long reaches. The same amount of mini-lever movement always produces the same grapple speed, no matter how long the reach.

Simple, fatigue-beating control

With IBC, operators no longer need to control each independent boom joint separately. Just control the grapple, and IBC automatically guides the boom and joints accordingly. IBC automatically controls the lift, slew, and extension of the boom based on the location of the grapple.

More efficient load handling

IBC makes load handling more efficient and increases productivity by as much as one load per day.

Choose how you work

Joysticks are now configurable to user preference, so operators can run IBC using their preferred control pattern. At startup, simply choose default pattern, ISO pattern, or knuckleboom (ISO inverted) control pattern through TimberMatic™.



UP TO
**1 MORE
LOAD PER DAY**
WITH OPTIONAL IBC

OPTIMIZED, NOT
COMPROMISED

Exceptional capability, stability, and versatility.

Whether you're thinning, regeneration felling, or clear-felling, your G-Series Forwarder is a master of uncompromising productivity.

Improved boom control

Boom control is more precise. High-capacity controllers, simplified CAN buses, and a streamlined electrical system improve the efficiency of machine functions, minimize malfunctions, and accelerate troubleshooting.

Versatile load space

Load space can be easily configured to your needs, enabling better and quicker grapple access. Variable Load Space (VLS) option allows load-space width to be adjusted, for more flexible forwarding and sorting of short pulp and energy wood.

Adaptive Driveline Control

Select the driving mode (Eco, Normal, or Power) that best fits conditions during high loads, and Adaptive Driveline Control automatically adjusts engine load to keep rpm steady. Select **Normal** mode for everyday operation or **Power** mode to get maximum tractive force in high-load situations. For lighter demands, **Economy** mode reduces engine speed and noise, while improving fuel efficiency.





MORE
POWER
AND
TORQUE
AT LOW RPM
THAN E-SERIES



DO YOUR LEVEL BEST

Comfortable and in control.

Boosting productivity includes keeping operators safe and comfortable. And G-Series Forwarders continue to set the standard for cab conveniences and control, maximizing productivity with minimal effort.

Rotating and leveling cab

Rotating and smooth-leveling cab turns 290 deg., providing 360-deg. visibility of surroundings and boom movements, for safe, efficient log loading. Auto-leveling cab keeps operators balanced and comfortable in steep and uneven terrain.

Automatic monitoring

Exclusive TimberMatic™ Analytics automatic monitoring system keeps an eye on operating costs while tracking machine performance and efficiency. Work-cycle information such as loading and driving times can be used to fine-tune settings and improve operator technique.

TimberMatic F-16

TimberMatic F-16 control system provides reliable, efficient control of all forwarder functions, for quicker, more precise boom movements and greater productivity. User-friendly software offers easy-to-learn and operator-specific patterns, so you can get the most out of your machine, every shift. New remote display and more detailed diagnostics speed troubleshooting.



No ACTIVE site 1:18 PM

Start site

Timbermatic



ROTATING/LEVELING
CAB TURNS 290°

FOR 360°
VISIBILITY



**JOHN DEERE CONNECTED SUPPORT™ /
JOHN DEERE FORESTSIGHT™ /
TIMBERMATIC™ MAPS AND TIMBERMANAGER™**

Because time is of the essence.

Loggers demand more uptime. Fast, accurate diagnosis of machine problems. Rapid, effective service response and the right part, the first time. And closer tracking of machines and operators, for efficient operation. John Deere forestry technology solutions are there to help.



Get valuable insight with

JOHN DEERE FORESTSIGHT

The in-base JDLink™ telematics subscription is the foundation of our John Deere ForestSight forestry technology solutions. To optimize productivity and efficiency, TimberMatic Maps helps eliminate guesswork for your operators related to routes and the location of timber. And TimberManager provides complete visibility to your operation — from land harvested to the machines at work — so you can streamline communication and increase efficiency.

With John Deere Connected Support, dealer machine monitoring and remote diagnostics and programming capability can quickly identify and diagnose problems that may occur, while machine health alerts developed through analyzing data from the entire population of John Deere machines can help prevent problems altogether.

Visualize more productivity with

TIMBERMATIC MAPS AND TIMBERMANAGER

TimberMatic Maps and TimberManager are proven jobsite-mapping tools designed for full-tree logging operations. TimberMatic Maps enables enhanced visibility, allowing operators to review production values as well as see and create points of interest that can be shared in real time with other onsite team members. Staff not on the jobsite can also access any of this data through TimberManager, to optimize tasks and increase efficiency.

Grouped service points

Grouped checkpoints and optional central lubrication system speed daily checks and greasing.

Servicing at full tilt

Operator station can be tilted in minutes, for wide-open access to internal components.

Common components

Reliable and flexibly interchangeable electronic components help reduce machine downtime. Commonality among the basic components of all John Deere Forestry equipment lowers your investment in service parts.

Run longer for less

Standard service intervals of 1,500 and 3,000 hours with intermediate service at 750 hours keep you running longer, at lower cost.



NO PAIN. K

Fuel-efficient hydraulic-driven fan

Hydraulic-driven variable-speed fan — available in the 1110G, 1210G, 1510G, and 1910G — runs only as needed, reducing fuel consumption and debris flow through the cooler cores. Program it to reverse at periodic intervals to clear core-clogging buildup.

More power and torque

PowerTech™ Plus diesels deliver more power and torque at low rpm compared to previous John Deere models, for excellent performance and fuel efficiency.

Self-cleaning filter

Self-cleaning engine air filter extends filter-change intervals and wear life, while lowering daily operating expenses.



NOW GAIN.

910G / 1010G

Engine	910G	1010G
Load Rating	9000 (19,842 lb.) / 10 000 kg (22,046 lb.)	11 000 kg (24,251 lb.)
Manufacturer and Model	John Deere PowerTech™ Plus 4045	John Deere PowerTech Plus 4045
Non-Road Emissions Standard	EPA Final Tier 4/EU Stage V	EPA Final Tier 4/EU Stage V
Net Peak Power	118 kW (160 hp) at 1,900 rpm	131 kW (178 hp) at 1,900 rpm
Net Peak Torque	650 Nm (479 ft.-lb.) at 1,400–1,600 rpm	730 Nm (538 ft.-lb.) at 1,400–1,600 rpm
Fuel Tank Capacity	150 L (39.6 gal.)	150 L (39.6 gal.)
Transmission	Hydrostatic-mechanical, 2-speed gearbox	
Tractive Force	150 kN (33,721 lbf.) with 24.5 tires / 110 kN (24,729 lbf.) with 22.5 tires	150 kN (33,721 lbf.) with 24.5 tires / 160 kN (35,969 lbf.) with 26.5 tires
Travel Speed	Gear 1 0–7.5 km/h (0–4.7 mph) Gear 2 0–23 km/h (0–14.3 mph)	
Steering	910G / 1010G	
Proportional steering with electrical joystick	44 deg.	
Brakes	Hydraulically actuated, oil-immersed, multi-disc	
Service	Spring actuated	
Parking/Emergency	Automated	
Axles/Bogies	Hydromechanical differential lock in front and rear	
Axles	Front Single rigid axle, non-balanced- or balanced-gear bogie axle Rear Balanced-gear bogie axle or unbalanced long bogie (LGP) (available only with 26.5 axles)	
Electrical	Voltage 24 volt Batteries 115 Ah Alternator 150 A Lights Halogen or LED	
Hydraulics	Load sensing Pump Capacity 120 cm ³ (7.3 cu. in.) Operating Pressure 24 MPa (3,480 psi) Hydraulic Tank 150 L (39.6 gal.)	
Boom	910G	1010G
Type	CF1	CF5
Maximum Reach Lengths	9.8 m (32.2 ft.)	8.5 m (27.9 ft.) / 10 m (32.8 ft.)
Gross Lifting Torque	76 kNm (56,000 ft.-lb.)	102 kNm (75,000 ft.-lb.)
Slewing Torque	19 kNm (14,000 ft.-lb.)	24 kNm (18,000 ft.-lb.)
Slewing Angle	380 deg.	380 deg.
Cabin	910G / 1010G	
Type	Fixed, rotating, or rotating and leveling	
Rotating Angle	290 deg.	
Tilt	Sideways 10 deg. Forward and Backward 6 deg.	
Control System	Windows®-based TimberMatic™ F-16 with high performance / Standard PC	
Boom Control Aid	Standard Smooth Boom Control (SBC) algorithm Optional Intelligent Boom Control (IBC) on CF5	



Measurements	910G	1010G
A Length		
Short Wheelbase	8655 mm (28.4 ft.)	8655 mm (28.4 ft.)
Medium Wheelbase	9055 mm (29.7 ft.)	9055 mm (29.7 ft.)
Long Wheelbase	N/A	9455 mm (31.0 ft.)
B Bogie Center – Middle Joint	1900 mm (5.9 ft.)	1900 mm (5.9 ft.)
C Middle Joint – Bogie Center		
Short Wheelbase	2600 mm (8.5 ft.)	2600 mm (8.5 ft.)
Medium Wheelbase	3000 mm (9.8 ft.)	3000 mm (9.8 ft.)
Long Wheelbase	N/A	3400 mm (11.2 ft.)
Wheelbase (B+C)		
Short	4400 mm (14.4 ft.)	4400 mm (14.4 ft.)
Medium	4800 mm (15.7 ft.)	4800 mm (15.7 ft.)
Long	N/A	5200 mm (17.1 ft.)
D Headboard – Bogie Center		
Short Wheelbase	1790 mm (5.9 ft.)	1790 mm (5.9 ft.)
Medium Wheelbase	2190 mm (7.2 ft.)	2190 mm (7.2 ft.)
Long Wheelbase	N/A	2590 mm (8.5 ft.)
E Bogie Center – Rear	1905 mm (6.3 ft.)	1905 mm (6.3 ft.)
F Width		
600-Series Tires	2553 mm (8.4 ft.) with 22.5 tires / 2570 mm (8.4 ft.) with 24.5 tires	2570 mm (8.4 ft.) with 24.5 tires / 2600 mm (8.5 ft.) with 26.5 tires
710-Series Tires	2703 mm (8.9 ft.) with 22.5 tires / 2780 mm (9.1 ft.) with 24.5 tires	2780 mm (9.1 ft.) with 24.5 tires / 2790 mm (9.2 ft.) with 26.5 tires
800-Series Tires	N/A	2940 mm (9.6 ft.)
Turning Angle	44 deg.	44 deg.
Outer Turning Radius – 710 x 24.5-Series Tires		
Short	7096 mm (23.3 ft.)	7096 mm (23.3 ft.)
Medium	7664 mm (25.1 ft.)	7664 mm (25.1 ft.)
Long	N/A	8234 mm (27.0 ft.)
Inner Turning Radius – 710 x 24.5-Series Tires		
Short	3874 mm (12.7 ft.)	3874 mm (12.7 ft.)
Medium	4288 mm (14.1 ft.)	4288 mm (14.1 ft.)
Long	N/A	4702 mm (15.4 ft.)
Transport Height	3672 mm (12.0 ft.) with 22.5 tires / 3685 mm (12.1 ft.) with 24.5 tires	3685 mm (12.1 ft.) with 24.5 tires / 3712 mm (12.2 ft.) with 26.5 tires
G Ground Clearance – 8W	625 mm (24.6 in.) with 22.5 tires / 638 mm (25.0 in.) with 24.5 tires	638 mm (25.0 in.) with 24.5 tires / 665 mm (26.0 in.) with 26.5 tires
Tires		
Front – 6W / 8W	34–14 / 22.5–20/24.5–20	34–14 / 24.5–20/26.5–20
Rear	22.5–20/24.5–20	24.5–20/26.5–20
Minimum Machine Weight		
6W	14 700 kg (32,408 lb.)	14 950 kg (32,959 lb.)
8W	14 950 kg (32,959 lb.)	16 050 kg (35,384 lb.)
Approach Angle	37 deg. with 22.5 tires / 38 deg. with 24.5 tires	38 deg. with 24.5 tires / 40 deg. with 26.5 tires

Load-Space Options*

Length (D+E)		
Short Wheelbase	3690 mm (12.1 ft.)	3690 mm (12.1 ft.)
Medium Wheelbase	4090 mm (13.4 ft.)	4090 mm (13.4 ft.)
Long Wheelbase	N/A	4490 mm (14.7 ft.)
Load-Space Width		
Minimum / Maximum	2500 mm (8.2 ft.) / 2700 mm (8.9 ft.)	2500 mm (8.2 ft.) / 2700 mm (8.9 ft.)
Cross-Sectional Area	3.5–4.0 m ² (377–431 sq. ft.)	3.5–4.0 m ² (377–431 sq. ft.)

910G / 1010G

Fixed Cab

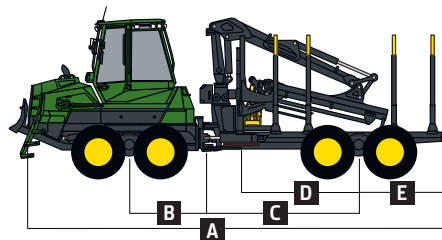

Front

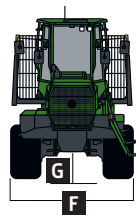

Rotating Cab

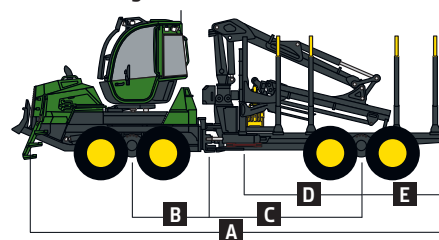

Front

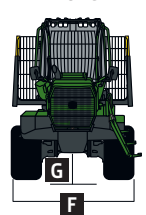

*Please note: Measurements are guidelines only and may vary depending on production tolerances. Machine not exactly as shown. Illustrations for dimensioning purposes only.

1110G / 1210G

Engine	1110G	1210G
Load Rating	12 000 kg (26,455 lb.)	13 000 kg (28,660 lb.)
Manufacturer and Model	John Deere PowerTech™ Plus 6068	John Deere PowerTech Plus 6068
Non-Road Emissions Standard	EPA Final Tier 4/EU Stage V / Tier 2/Stage II	EPA Final Tier 4/EU Stage V / Tier 2/Stage II
Net Peak Power	145 kW (194 hp) at 1,600–1,900 rpm	156 kW (209 hp) at 1,600–1,900 rpm
Net Peak Torque	865 Nm (638 ft.-lb.) at 1,300–1,600 rpm	935 Nm (690 ft.-lb.) at 1,300–1,500 rpm
Fuel Tank Capacity	167 L (44 gal.)	167 L (44 gal.)
Transmission	Hydrostatic-mechanical, 2-speed gearbox	
Tractive Force	160 kN (35,968 lbf.)	175 kN (39,340 lbf.)
Travel Speed	Gear 1 0–7.5 km/h (0–4.3 mph)	
	Gear 2 0–23 km/h (0–14.3 mph)	
Steering	Proportional steering with electrical joystick	
Turning Angle	44 deg.	44 deg.
Brakes	1110G / 1210G	
Service	Hydraulically actuated, oil-immersed, multi-disc	
Parking/Emergency	Spring actuated	
Frame	Automated	
Axles/Bogies	1110G	1210G
Hydromechanical differential lock in front and rear		
Axles	Front Single rigid axle, non-balanced- or balanced-gear bogie axle	
	Rear Balanced-gear bogie axle or unbalanced long bogie (LGP)	
	Heavy-duty (HD) bogie axle or unbalanced long bogie (LGP)	
Electrical	1110G / 1210G	
Voltage	24 volt	
Batteries	145 Ah	
Alternator	150 A	
Lights	Halogen	
Hydraulics	1110G	1210G
Load sensing	Pump Capacity 140 cm ³ (9.0 cu. in.)	
	Operating Pressure 24 MPa (3,480 psi)	
	Hydraulic Tank 161 L (43 gal.)	
	160 cm ³ (10.0 cu. in.)	
	24 MPa (3,480 psi)	
	161 L (43 gal.)	
Boom	1110G / 1210G	
Type	CF5	CF7
Maximum Reach Lengths	8.5 m (27.9 ft.) / 10 m (32.8 ft.)	8.5 m (27.9 ft.) / 10 m (32.8 ft.)
Gross Lifting Torque	102 kNm (75,000 ft.-lb.)	125 kNm (92,000 ft.-lb.)
Slewing Torque	24 kNm (18,000 ft.-lb.)	32 kNm (24,000 ft.-lb.)
Slewing Angle	380 deg.	380 deg.
Cabin	1110G / 1210G	
Type	Fixed, rotating, or rotating and leveling	
Rotating Angle	290 deg.	
Tilt	Sideways 10 deg.	
	Forward and Backward 6 deg.	
Control System	1110G / 1210G	
PC / Windows®-based TimberMatic™ F-16		
Boom Control Aid	Standard Smooth Boom Control (SBC) algorithm	
	Optional Intelligent Boom Control (IBC) on CF5 and CF7	



Measurements	1110G	1210G
A Length		
Short / Medium Wheelbase	9820 mm (32.2 ft.)	9820 mm (32.2 ft.)
Long Wheelbase	10 820 mm (35.5 ft.)	10 820 mm (35.5 ft.)
B Bogie Center – Middle Joint	1900 mm (6.2 ft.)	1900 mm (6.2 ft.)
C Middle Joint – Bogie Center		
Short Wheelbase	3000 mm (9.8 ft.)	3000 mm (9.8 ft.)
Medium Wheelbase	3400 mm (11.2 ft.)	3400 mm (11.2 ft.)
Long Wheelbase	3800 mm (12.5 ft.)	3800 mm (12.5 ft.)
Wheelbase (B+C)		
Short	4900 mm (16.1 ft.)	4900 mm (16.1 ft.)
Medium	5300 mm (17.4 ft.)	5300 mm (17.4 ft.)
Long	5700 mm (18.7 ft.)	5700 mm (18.7 ft.)
D Headboard – Bogie Center		
Short Wheelbase	2200 mm (7.2 ft.)	2200 mm (7.2 ft.)
Medium Wheelbase	2600 mm (8.5 ft.)	2600 mm (8.5 ft.)
Long Wheelbase	3000 mm (9.8 ft.)	3000 mm (9.8 ft.)
E Bogie Center – Rear		
Short Wheelbase	2300 mm (7.5 ft.)	2300 mm (7.5 ft.)
Medium Wheelbase	1900 mm (6.2 ft.)	1900 mm (6.2 ft.)
Long Wheelbase	2500 mm (8.2 ft.)	2500 mm (8.2 ft.)
F Width		
600-Series Tires	2700 mm (8.9 ft.)	2746 mm (9.0 ft.)
700-Series Tires	2890 mm (9.5 ft.)	2956 mm (9.7 ft.)
800-Series Tires	2990 mm (9.8 ft.)	3086 mm (10.1 ft.)
Turning Angle	44 deg.	44 deg.
Outer Turning Radius – 700-Series Tires		
Short	7835 mm (25.7 ft.)	7870 mm (25.8 ft.)
Medium	8400 mm (27.6 ft.)	8440 mm (27.7 ft.)
Long	8980 mm (29.5 ft.)	9010 mm (29.6 ft.)
Inner Turning Radius – 700-Series Tires		
Short	4400 mm (14.4 ft.)	4380 mm (14.4 ft.)
Medium	4820 mm (15.8 ft.)	4790 mm (15.7 ft.)
Long	5230 mm (17.2 ft.)	5200 mm (17.1 ft.)
Transport Height	3870 mm (12.7 ft.)	3800 mm (12.5 ft.)
G Ground Clearance – 8W	660 mm (26.0 in.)	660 mm (26.0 in.)
Tires		
Front – 6W / 8W	34–14 / 26.5–20	34–14 / 26.5–20
Rear	26.5–20	26.5–20
Minimum Machine Weight		
6W	15 330 kg (33,797 lb.)	16 180 kg (35,671 lb.)
8W	17 130 kg (37,765 lb.)	18 080 kg (39,860 lb.)
Approach Angle – 8W	35 deg.	35 deg.
Load-Space Options*		
Load Space Length (D+E)		
Short / Medium Wheelbase	4500 mm (14.8 ft.)	4500 mm (14.8 ft.)
Long Wheelbase	5500 mm (18.0 ft.)	5500 mm (18.0 ft.)
Variable Load Space (VLS)	N/A	4500 mm (14.8 ft.)
Load-Space Width		
Minimum / Maximum	2700 mm (8.9 ft.) / 3149 mm (10.3 ft.)	2663 mm (8.7 ft.) / 3406 mm (11.2 ft.)
VLS	N/A	2760–3300 mm (9.0–10.8 ft.)
Cross-Sectional Area	4.0–4.6 m ² (43.0–49.5 sq. ft.)	4.0–5.3 m ² (43.0–57.0 sq. ft.)
VLS	N/A	4.1–5.1 m ² (44.1–55.0 sq. ft.)

1110G / 1210G

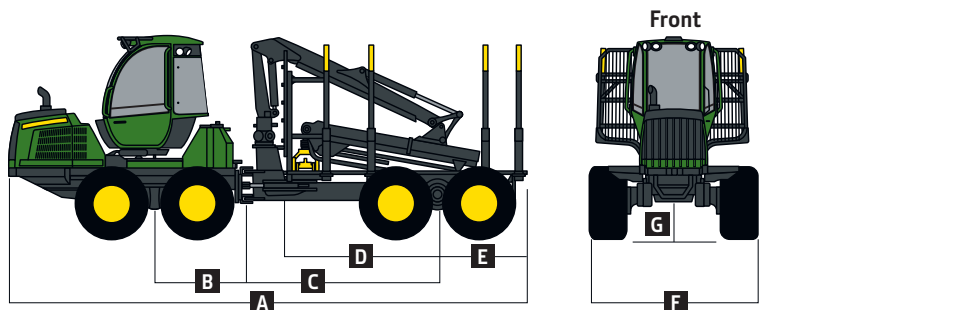

*Please note: Measurements are guidelines only and may vary depending on production tolerances. Machine not exactly as shown. Illustrations for dimensioning purposes only.

1510G / 1910G

Engine	1510G	1910G
Load Rating	15 000 kg (33,069 lb.)	19 000 kg (41,888 lb.)
Manufacturer and Model	John Deere PowerTech™ Plus 6068	John Deere PowerTech Plus 6090
Non-Road Emissions Standard	EPA Final Tier 4/EU Stage V / Tier 3/Stage IIIA / Tier 2/Stage II	EPA Final Tier 4 (FT4)/EU Stage V
Net Peak Power	164 kW (220 hp) at 1,700–1,900 rpm	200 kW (268 hp) at 1,600–1,900 rpm
Net Peak Torque	978 Nm (721 ft.-lb.) at 1,200–1,500 rpm	1315 Nm (970 ft.-lb.) at 1,400 rpm
Fuel Tank Capacity	167 L (44 gal.)	184 L (49 gal.)
Transmission		
Hydrostatic-mechanical, 2-speed gearbox		
Tractive Force	185 kN (41,588 lbf.)	230 kN (51,704 lbf.)
Travel Speed		
Gear 1	0–7.5 km/h (0–4.3 mph)	0–7 km/h (0–4.3 mph)
Gear 2	0–23 km/h (0–14.3 mph)	0–21 km/h (0–13.0 mph)
Steering		
Proportional steering with electrical joystick		
Turning Angle	44 deg.	42 deg.
Brakes	1510G / 1910G	
Service	Hydraulically actuated, oil-immersed, multi-disc	
Parking/Emergency	Spring actuated	
Frame	Automated	
Axles/Bogies	1510G	1910G
Hydromechanical differential lock in front and rear		
Axles		
Front	Single rigid axle, non-balanced- or balanced-gear heavy-duty (HD) bogie axle	Single rigid axle or balanced-gear HD bogie axle
Rear	Balanced-gear HD bogie axle or unbalanced long bogie (LGP)	Balanced-gear HD bogie axle
Electrical		
Voltage	24 volt	24 volt
Batteries	145 Ah	149 Ah
Alternator	150 A	150 A
Lights	Halogen	Halogen
Hydraulics		
Load sensing		
Pump Capacity	180 cm ³ (11.0 cu. in.)	180 cm ³ (11.0 cu. in.)
Operating Pressure	24 MPa (3,480 psi)	24 MPa (3,480 psi)
Hydraulic Tank	161 L (43 gal.)	185 L (49 gal.)
Boom		
Type	CF7/CF7S	CF8
Maximum Reach Lengths	8.5 m (27.9 ft.) / 10 m (32.8 ft.)	7.3 m (23.9 ft.) / 8.5 m (27.9 ft.)
Gross Lifting Torque	125 kNm (92,000 ft.-lb.) / 143 kNm (105,500 ft.-lb.)	151 kNm (111,000 ft.-lb.)
Slewing Torque	32 kNm (24,000 ft.-lb.)	41 kNm (30,000 ft.-lb.)
Slewing Angle	380 deg.	380 deg.
Cabin		
Type	Fixed, rotating, or rotating and leveling	Fixed or rotating and leveling
Rotating Angle	290 deg.	290 deg.
Tilt		
Sideways	10 deg.	10 deg.
Forward and Backward	6 deg.	6 deg.
Control System		
Type	PC / Windows®-based TimberMatic™ F-16	PC / Windows-based TimberMatic F-16
Boom Control Aid		
Standard	Smooth Boom Control (SBC) algorithm	
Optional	Intelligent Boom Control (IBC) on CF7, CF7S, and CF8	



Measurements	1510G	1910G
A Length		
Short Wheelbase	9820 mm (32.2 ft.)	10 567 mm (34.7 ft.)
Long Wheelbase	11 020 mm (36.1 ft.)	11 467 mm (37.6 ft.)
B Bogie Center – Middle Joint	1900 mm (6.2 ft.)	2150 mm (7.1 ft.)
C Middle Joint – Bogie Center		
Short Wheelbase	3400 mm (11.2 ft.)	3600 mm (11.8 ft.)
Long Wheelbase	4000 mm (13.1 ft.)	4100 mm (13.4 ft.)
Wheelbase (B+C)		
Short	4900 mm (16.1 ft.)	N/A
Medium	5300 mm (17.4 ft.)	5750 mm (18.9 ft.)
Long	5900 mm (19.4 ft.)	6250 mm (20.5 ft.)
D Headboard – Bogie Center		
Short Wheelbase	2600 mm (8.5 ft.)	2635 mm (8.6 ft.)
Long Wheelbase	3200 mm (10.5 ft.)	3135 mm (10.3 ft.)
E Bogie Center – Rear		
Short Wheelbase	1900 mm (6.2 ft.)	2100 mm (6.9 ft.)
Long Wheelbase	2500 mm (8.2 ft.)	2500 mm (8.2 ft.)
F Width		
700-Series Tires	2956 mm (9.7 ft.)	3090 mm (10.1 ft.)
800-Series Tires	3086 mm (10.1 ft.)	N/A
Turning Angle	44 deg.	42 deg.
Outer Turning Radius – 700-Series Tires		
Short	8180 mm (26.8 ft.)	9422 mm (30.9 ft.)
Medium	8764 mm (28.7 ft.)	N/A
Long	9652 mm (31.7 ft.)	10 160 mm (33.3 ft.)
Inner Turning Radius – 700-Series Tires		
Short	4700 mm (15.4 ft.)	3090 mm (10.1 ft.)
Medium	5140 mm (16.9 ft.)	N/A
Long	5804 mm (19.0 ft.)	6222 mm (20.4 ft.)
Transport Height	3800 mm (12.5 ft.)	4039 mm (13.2 ft.)
G Ground Clearance – 8W	660 mm (26.0 in.)	803 mm (31.6 in.)
Tires		
Front – 6W / 8W	34–14 / 26.5–20	34–16 / 26.5–20
Rear	26.5–20	26.5–20
Minimum Machine Weight		
6W	16 330 kg (36,001 lb.)	19 485 kg (42,957 lb.)
8W	18 230 kg (40,190 lb.)	22 227 kg (49,002 lb.)
Approach Angle – 8W	35 deg.	39 deg.
Load-Space Options*		
Length (D+E)		
Short Wheelbase	4500 mm (14.8 ft.)	5635 mm (18.5 ft.)
Long Wheelbase	5700 mm (18.7 ft.)	4735 mm (15.5 ft.)
Variable Load Space (VLS)	4500 mm (14.8 ft.)	4735 mm (15.5 ft.)
Load-Space Width		
Minimum / Maximum	2700 mm (8.9 ft.) / 3406 mm (11.2 ft.)	2950 mm (9.7 ft.) / 3610 mm (11.8 ft.)
VLS	2750–3390 mm (9.0–11.1 ft.)	2963–3603 mm (9.7–11.8 ft.)
Cross-Sectional Area	4.0–5.3 m ² (43.0–57.0 sq. ft.)	5.5–6.8 m ² (59.2–73.2 sq. ft.)
VLS	4.3–5.3 m ² (46.3–57.0 sq. ft.)	5.4–6.6 m ² (58.1–71.0 sq. ft.)

1510G

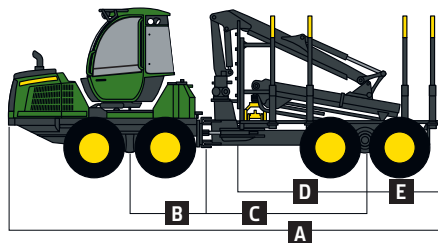

Front

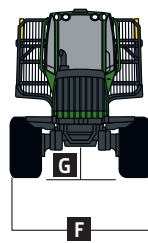

1910G

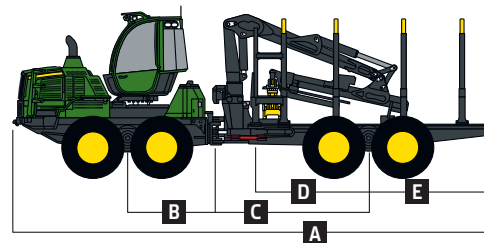

Front

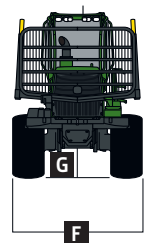

*Please note: Measurements are guidelines only and may vary depending on production tolerances. Machine not exactly as shown. Illustrations for dimensioning purposes only.



JOHN DEERE

JohnDeere.com/forestry

TO FIND SUCCESS IN THE FOREST,
YOU CAN WAIT FOR THE PERFECT SET OF CONDITIONS.

Or give yourself every advantage to create your own.
Productive machines. Innovative technology. Useful
insights. Dependable support.

The obstacles to success are many. John Deere helps you

OUTRUN™ THEM ALL.